

# TECHNICAL CATALOGUE

## Collezione Home – HOME COLLECTION



# Indice prodotti / Product index

## 01 Tavoli /

Table

8	<a href="#">Adam</a>
10	<a href="#">Clemo - T</a>
12	<a href="#">Dolm</a>
14	<a href="#">Dolm Plus</a>
16	<a href="#">Eros</a>
18	<a href="#">Eyl</a>
20	<a href="#">Haumea-T</a>
22	<a href="#">Maat</a>
26	<a href="#">Manto</a>
30	<a href="#">Manto Oval</a>
34	<a href="#">Molecola</a>
36	<a href="#">Oto</a>
40	<a href="#">Oto Big</a>
42	<a href="#">Oto Medium</a>
44	<a href="#">Platium</a>
46	<a href="#">Platium Round</a>
48	<a href="#">Platium System</a>
50	<a href="#">Platium W</a>
52	<a href="#">Prism</a>
54	<a href="#">Re-verre Table</a>
56	<a href="#">Selce-T</a>
58	<a href="#">Shiro</a>
60	<a href="#">Simpòdio</a>
62	<a href="#">Simpòdio System</a>
64	<a href="#">Yol</a>
66	<a href="#">Yol Sect</a>
68	<a href="#">Zen</a>
72	<a href="#">Zen Black</a>
74	<a href="#">Lazy Susan</a>
76	<a href="#">Informazioni tecniche/ Technical informations</a>

## 02 Sedute /

Seatings

94	<a href="#">0414</a>
98	<a href="#">0419</a>
100	<a href="#">Akiko</a>
102	<a href="#">H2O</a>
104	<a href="#">Jackie</a>
106	<a href="#">Janette</a>
108	<a href="#">Keyko</a>
110	<a href="#">Livrette</a>
112	<a href="#">Thea</a>
114	<a href="#">Thea Barstool</a>
116	<a href="#">Thea Queen</a>
118	<a href="#">Informazioni tecniche/ Technical informations</a>

## 03 Carrelli /

Trolleys

128	<a href="#">Mister</a>
130	<a href="#">Riki</a>
132	<a href="#">Informazioni tecniche/ Technical informations</a>

## 04 Panche e Pouf /

Benches and Pouffe

138	<a href="#">Audrey Pouf</a>
140	<a href="#">Cloud Pouf</a>
142	<a href="#">Lilas Bench</a>
144	<a href="#">Lou</a>
146	<a href="#">Oly</a>
148	<a href="#">Sensei Bench</a>
150	<a href="#">Stami Bench</a>
152	<a href="#">Stami DayBed</a>
154	<a href="#">Stami Pouf</a>
156	<a href="#">Twelve DayBed</a>
158	<a href="#">Informazioni tecniche/ Technical informations</a>

## 05 Divani e poltrone /

Sofas and armchairs

168	<a href="#">0417</a>
170	<a href="#">Akiko Lounge</a>
172	<a href="#">Audrey</a>
174	<a href="#">Audrey Motion</a>
176	<a href="#">Audrey Poltrona</a>
178	<a href="#">Cloud</a>
180	<a href="#">Cloud Chiase Longue</a>
182	<a href="#">Cloud Infinity</a>
184	<a href="#">Cloud Poltrona</a>
186	<a href="#">Elissa</a>
188	<a href="#">Elissa Sectional</a>
192	<a href="#">Fiona</a>
194	<a href="#">Fiona Soft</a>
196	<a href="#">First</a>
198	<a href="#">First Modulare</a>
200	<a href="#">First Poltrona &amp; Pouf</a>
202	<a href="#">Lilas</a>
204	<a href="#">Lilas Mosaïque</a>
206	<a href="#">Livre</a>
208	<a href="#">Sophie</a>
210	<a href="#">Sophie Sofa</a>
212	<a href="#">Stami Lounge</a>
214	<a href="#">Stami Loveseat</a>
216	<a href="#">Stami Sofa</a>
218	<a href="#">Stami Sofa Plus</a>
222	<a href="#">Informazioni tecniche/ Technical informations</a>

## 06 Tavolini /

Coffee Tables

256	<a href="#">1968</a>
258	<a href="#">Chantal</a>
260	<a href="#">Clemo</a>
264	<a href="#">Connection</a>
266	<a href="#">Cookies</a>
268	<a href="#">Cookies Circle</a>
270	<a href="#">Dama</a>
272	<a href="#">Drummers</a>
274	<a href="#">Fante</a>
276	<a href="#">Faraday</a>
278	<a href="#">George 1</a>
280	<a href="#">George 2</a>
282	<a href="#">Golden Moon</a>
284	<a href="#">Gong</a>
286	<a href="#">Haumea</a>
290	<a href="#">Hide&amp;Seek Mini</a>
292	<a href="#">Monete</a>
296	<a href="#">Nori</a>
298	<a href="#">Nox</a>
300	<a href="#">Oto Mini</a>
302	<a href="#">Prism Low</a>
304	<a href="#">Raj 1</a>
306	<a href="#">Raj 2</a>
308	<a href="#">Raj 3</a>
310	<a href="#">Raj 6</a>
312	<a href="#">Re-verre</a>
316	<a href="#">Selce</a>
318	<a href="#">Sensei</a>
320	<a href="#">Sir T 32/Sir T 32 C</a>
322	<a href="#">T33</a>
324	<a href="#">T35 R</a>
326	<a href="#">T 35 Trio</a>
328	<a href="#">Tetris</a>
330	<a href="#">Twelve</a>
332	<a href="#">Zen Black Low</a>
334	<a href="#">Zen Low</a>
336	<a href="#">Informazioni tecniche/ Technical informations</a>

# Indice prodotti / Product index

## 07 Consolle / Consoles

356 [Athus Console](#)  
358 [Dolm Console](#)  
360 [Hanami](#)  
362 [Sensei Console](#)  
364 [Tama Console](#)

366 [Informazioni tecniche/  
Technical informations](#)

## 08 Contenitori / Storage Units

372 [5th Avenue](#)  
374 [5th Avenue Crédence](#)  
376 [Athus](#)  
378 [Diedro](#)  
382 [Gastone](#)  
384 [Gastone Low](#)  
386 [Hide&Seek](#)  
390 [Hide&Seek Door](#)  
392 [Kumi](#)  
394 [Pandora](#)  
396 [Pandora Cashmere](#)  
398 [Pandora Craquelé](#)  
400 [Pandora Light](#)  
402 [Soda](#)  
406 [Stami Sideboard](#)  
408 [Tama](#)  
410 [Tama Crédence](#)  
412 [Tama Vitrine](#)

414 [Informazioni tecniche/  
Technical informations](#)

## 09 Librerie e boiserie / Shelving systems and boiserie

430 [Brera](#)  
432 [Brera 23](#)  
434 [Drizzle](#)  
436 [Isola](#)  
440 [Navigli](#)  
442 [Pleiadi](#)  
444 [Prism Divider](#)  
448 [Roundcut](#)  
450 [Syil](#)  
452 [Tortona](#)

454 [Informazioni tecniche/  
Technical informations](#)

# Indice prodotti / Product index

## 13 Divisori / Dividers

542 [Chloé](#)  
544 [Shield](#)

546 [Informazioni tecniche/  
Technical informations](#)

## 14 Lampade / Lightings

552 [Bolle 4](#)  
554 [Bolle 6](#)  
556 [Bolle Aria](#)  
558 [Bolle Cielo](#)  
560 [Bolle Orizzontale](#)  
562 [Bolle Sola](#)  
564 [Bolle Stelo](#)  
566 [Bolle Tavolo 1](#)  
568 [Bolle Tavolo 3](#)  
570 [Bolle Tela](#)  
572 [Bolle Terra](#)  
574 [Bolle Verticale](#)  
576 [Bonfire](#)  
578 [Diantha](#)  
580 [Diantha Terra](#)  
582 [Epsilon](#)  
584 [Epsilon Sola](#)  
586 [Eris](#)  
588 [Jolie](#)  
590 [Jolie Applique](#)  
592 [Key-to-Heaven](#)  
594 [Key-to-Heaven Fix](#)  
596 [Narghilè](#)  
598 [Ori](#)  
600 [Spectrum](#)

602 [Informazioni tecniche/  
Technical informations](#)

## 15 Specchi / Mirrors

618 [Black&White Beats](#)  
620 [Cubista](#)  
622 [Dream](#)  
624 [Garda](#)  
626 [Gemma](#)  
628 [Keplero](#)  
630 [Leaf](#)  
632 [Lebel 10](#)  
634 [Niagara](#)  
636 [Odette](#)  
638 [Selene Mirror](#)  
640 [Soft](#)  
642 [Sole](#)  
644 [Zed](#)  
646 [Zeiss Mirror](#)

648 [Informazioni tecniche/  
Technical informations](#)

## 10 Letti / Beds

472 [Eye](#)  
474 [Lilas Bed](#)  
476 [Sunrise](#)  
478 [Xeni](#)  
480 [Yuki](#)

482 [Informazioni tecniche/  
Technical informations](#)

## 11 Complementi notte / Night accessories

492 [Duale](#)  
494 [Hide&Seek Mini](#)  
496 [Holly Comò](#)  
498 [Holly Comodino](#)  
500 [Kumi](#)  
502 [Stami Night](#)  
504 [Twelve C](#)

506 [Informazioni tecniche/  
Technical informations](#)

## 12 Scrittoi e Vanity / Desks and Vanity

514 [Lui](#)  
516 [President Junior/President Senior](#)  
518 [President Junior/President Senior 50<sup>th</sup>](#)  
520 [Prism Desk](#)  
522 [Selene](#)  
524 [Sensei Desk](#)  
526 [Soho](#)  
528 [Stami](#)  
530 [Tama Secrétaire](#)  
532 [Venere](#)

534 [Informazioni tecniche/  
Technical informations](#)

## 16 Elementi decorativi / Decorative elements

658 [Lazy Susan](#)  
660 [Leaf Sculpture](#)

662 [Informazioni tecniche/  
Technical informations](#)

## 17 Tappeti / Rugs

668 [Ato](#)  
670 [Metaphores](#)  
674 [Resia](#)  
676 [Ruggy](#)

678 [Informazioni tecniche/  
Technical informations](#)

## 18 Accessori / Accessories

686 [Vase 1968](#)  
688 [Candle Holder](#)  
689 [Candle Holder Hexagonal](#)  
690 [Desk Card Holder](#)  
692 [Desk Set](#)  
694 [Flabello](#)  
696 [Folded Tray](#)  
698 [Iperboarea](#)  
700 [Moonlight](#)  
701 [Mouse Pad](#)  
702 [Odette Tray](#)  
704 [Paperweight](#)  
706 [Pleiadi](#)  
708 [Segno](#)  
709 [Teddy](#)  
710 [Tic Tac 14](#)  
712 [Tip Tap Toe](#)

714 [Informazioni tecniche/  
Technical informations](#)

## **01 Tavoli /**

Table

8	<a href="#">Adam</a>
10	<a href="#">Clemo - T</a>
12	<a href="#">Dolm</a>
14	<a href="#">Dolm Plus</a>
16	<a href="#">Eros</a>
18	<a href="#">Eyl</a>
20	<a href="#">Haumea-T</a>
22	<a href="#">Maat</a>
26	<a href="#">Manto</a>
30	<a href="#">Manto Oval</a>
34	<a href="#">Molecola</a>
36	<a href="#">Oto</a>
40	<a href="#">Oto Big</a>
42	<a href="#">Oto Medium</a>
44	<a href="#">Platium</a>
46	<a href="#">Platium Round</a>
48	<a href="#">Platium System</a>
50	<a href="#">Platium W</a>
52	<a href="#">Prism</a>
54	<a href="#">Re-verre Table</a>
56	<a href="#">Selce-T</a>
58	<a href="#">Shiro</a>
60	<a href="#">Simpòdio</a>
62	<a href="#">Simpòdio System</a>
64	<a href="#">Yol</a>
66	<a href="#">Yol Sect</a>
68	<a href="#">Zen</a>
72	<a href="#">Zen Black</a>
74	<a href="#">Lazy Susan</a>
76	<a href="#">Informazioni tecniche/ Technical informations</a>

# Adam

Studio G&R / 1971

Tavolo in cristallo trasparente 15mm. Basamenti in cristallo 15mm, curvati a fuoco e molati a mano. Parti metalliche cromate. Disponibile anche senza parti metalliche (altezza finita: 72 cm). Su richiesta si realizzano piani con dimensioni speciali.

Table in 15mm transparent glass. Bases in 15mm glass curved by fire and hand bevelled. Chromed metal clips. Also available without metal parts (total height: 72 cm). Customised sizes for the top on request.

! Per piani di dimensioni superiori a 260cm sono previste 4 basi.  
Grazie al peso del cristallo il piano viene solo appoggiato sulla base e non necessita di fissaggio.

! For glass top larger than 260cm, 4 bases are provided.  
Thanks to the weight of the glass, the top is only placed on the base and does not need to be fixed.



Cm	Inches
○ Ø 130 x 74 Ø 150 x 74	Ø 51¼" x 29¼" Ø 59¼" x 29¼"
○ 160 x 130 x 74 180 x 130 x 74 210 x 130 x 74	63" x 51¼" x 29¼" 71" x 51¼" x 29¼" 82¾" x 51¼" x 29¼"
○ 210 x 120 x 74 240 x 120 x 74 260 x 120 x 74	82¾" x 47¼" x 29¼" 94½" x 47¼" x 29¼" 102½" x 47¼" x 29¼"
○ Piano spessore 19mm 280 x 120 x 74 300 x 120 x 74	Top thickness 19mm 110¼" x 47¼" x 29¼" 118¼" x 47¼" x 29¼"

For technical drawing / p. 80

Pricelist 2023 / p. 10

## PIANO/TOP



Cristallo trasparente  
Transparent glass

## PARTI METALLICHE /METAL PARTS



Metallo cromato  
Chromed metal



# Clemo - T

Massimo Castagna / 2022

Tavolo in marmo 20mm Arabescato Orobico Rosso satinato, disponibile anche in Ceppo di Gré® spazzolato oppure in marmo Bianco Carrara Gioia satinato. Dettagli in metallo brunito a mano "dark".

Table in 20mm Arabescato Orobico Rosso satin marble. Also available in brushed Ceppo di Gré® or satin Bianco Carrara Gioia marble. "Dark" hand burnished metal details.

## NOTE TECNICHE SUI MATERIALI

**CEPPO DI GRÉ® - MARMO** | Il marmo è un materiale naturale di origine sedimentaria che può presentare particolarità come venature, lievi irregolarità superficiali, colorazioni differenti e cristallizzazioni. Queste peculiarità sono da attribuirsi alla naturalezza del materiale e non sono da considerarsi difetti ma caratteristiche tipiche del marmo. Ogni prodotto risulterà unico, esclusivo e non replicabile. I nostri marmi vengono trattati con un prodotto idrorepellente che permette una maggiore protezione della superficie stessa, aumentando l'impermeabilità. Questo trattamento non esclude la vulnerabilità del marmo alle sostanze acide.

## TECHNICAL INFORMATION ON THE MATERIALS

**CEPPO DI GRÉ® - MARBLE** | The marble is a natural material of sedimentary origin that can present particularities such as veins, slight surface irregularities, different colors and crystallizations. These peculiarities are to be attributed to the naturalness of the material and are not to be considered defects but typical characteristics of marble. Each product will be unique, exclusive and non-replicable. Our marbles are treated with water-repellent products which affords greater protection to the surface of the marble, improving its impermeability. This treatment doesn't exclude the vulnerability of the marble to acid substances.



### Cm

170 x 130 x 74  
170 x 170 x 74  
260 x 130 x 74  
260 x 170 x 74

### Inches

67" x 51¼" x 29¼"  
67" x 67" x 29¼"  
102½" x 51¼" x 29¼"  
102½" x 67" x 29¼"

For technical drawing / p. 80

Pricelist 2023 / p. 11  
Homescapes, gentle attitude / pp. 15-19

## STRUTTURA/STRUCTURE



**Marmo Arabescato Orobico Rosso satinato**  
Arabescato Orobico Rosso satin marble

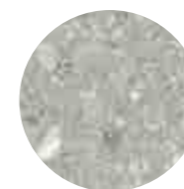

**Ceppo di Gré® spazzolato**  
Brushed Ceppo di Gré®



**Marmo Bianco Carrara Gioia spazzolato**  
Brushed Bianco Carrara Gioia marble

## DETTAGLI/DETAILS



**Metallo brunito a mano "dark"**  
"Dark" hand burnished metal

▲ **CLEMO - T**  
Marmo Arabescato Orobico Rosso / Parti metalliche in metallo brunito a mano "dark"  
Arabescato Orobico Rosso marble / "Dark" hand burnished metal parts

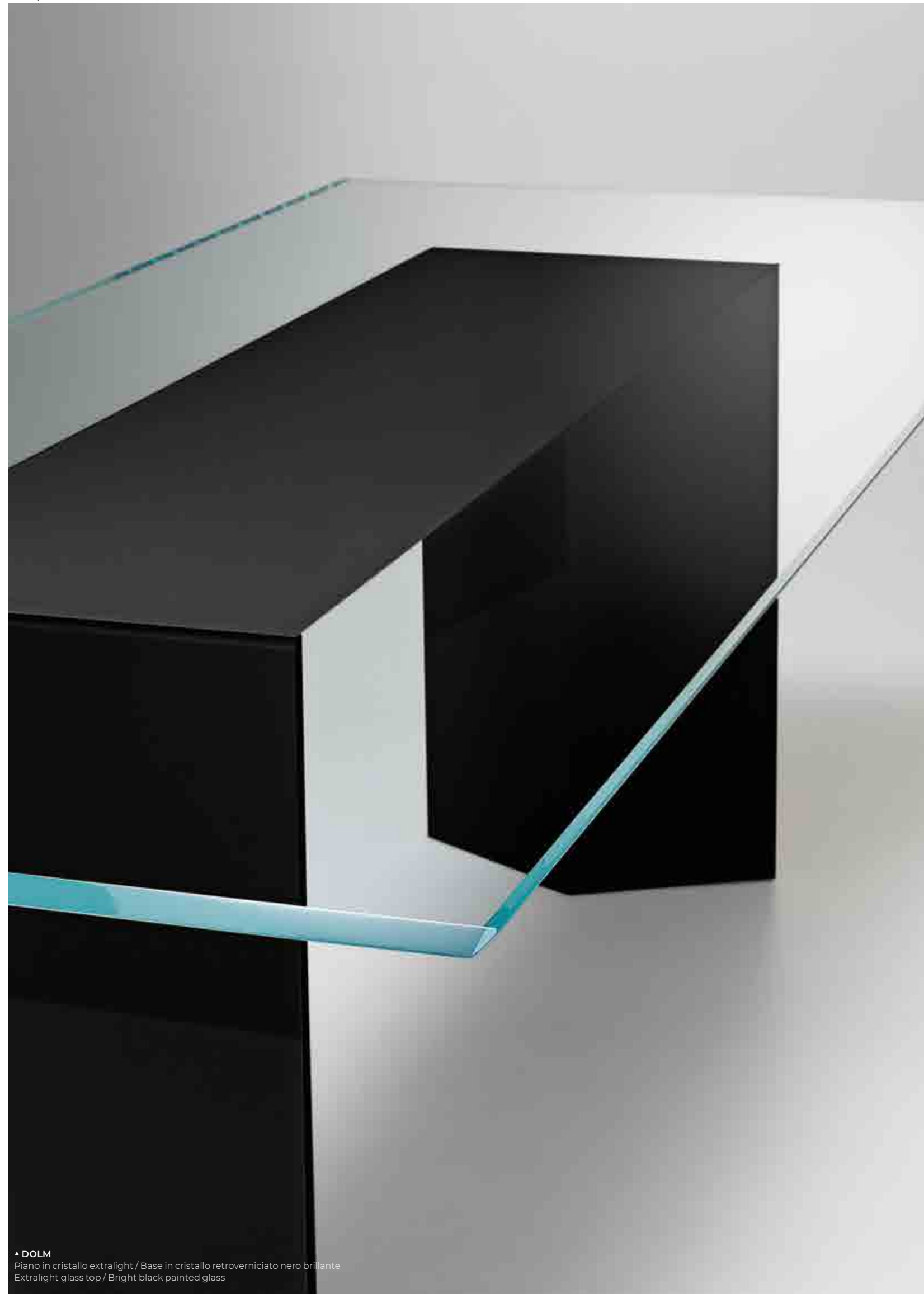

▲ DOLM  
Piano in cristallo extralight / Base in cristallo retroverniciato nero brillante  
Extralight glass top / Bright black painted glass

# Dolm

Oscar e Gabriele Buratti / 2012

Tavolo con piano in cristallo extralight 15mm, retroverniciato solo nella parte centrale nei colori del campionario nella versione brillante. Piano con bisello alternato a 45°. Disponibile anche nella versione con piano non bisellato. Basi in legno rivestite in cristallo 6mm temperato retroverniciato brillante.

! La retroverniciatura del piano nella parte centrale è realizzabile esclusivamente nella versione brillante.

L'azienda si riserva di scegliere il colore della trave in metallo coordinandola con la finitura del cristallo.

Grazie al peso del cristallo il piano viene solo appoggiato sulla base e non necessita di fissaggio.

Table with 15mm extralight glass top, painted only in the middle part as per samples in the bright version. 45° alternated bevelled glass top. Also available in the version with not bevelled glass top. Wooden base covered by 6mm tempered bright painted glass.

! The painting of the glass top in the middle part can only be done in the bright version.

The company reserves the right to choose the colour of the metal beam, matching it with the glass finish.

Thanks to the weight of the glass, the top is only placed on the base and does not need to be fixed.



## Cm

200 x 100 x 74  
240 x 100 x 74  
280 x 110 x 74  
320 x 110 x 74  
360 x 110 x 74

## Inches

78¾" x 39½" x 29¼"  
94½" x 39½" x 29¼"  
110¼" x 43½" x 29¼"  
126" x 43½" x 29¼"  
141¾" x 43½" x 29¼"

For technical drawing / p. 80

Pricelist 2023 / p. 12

## PIANO/TOP



Cristallo extralight  
Extralight glass

## PARTE CENTRALE PIANO/ MIDDLE PART TOP

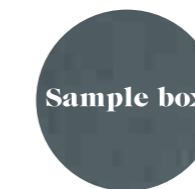

Cristallo retroverniciato brillante  
nei colori del campionario  
Bright painted glass  
as per samples

## BASE/BASE

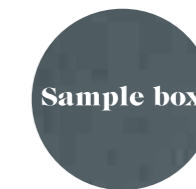

Cristallo retroverniciato brillante  
nei colori del campionario  
Bright painted glass  
as per samples



# Dolm Plus

Oscar e Gabriele Buratti / 2019

Tavolo con piano in cristallo 15mm verniciato nella finitura esclusiva spazzolata "Cashmere" nei colori gold grey o anthracite oppure nella finitura esclusiva bronzo antico o piombo. Importante bisellatura di 60mm su tutti i lati del piano. Basi in legno rivestite in cristallo 6mm verniciato temperato nella stessa finitura del piano.

! L'azienda si riserva di scegliere il colore della trave in metallo coordinandola con la finitura del cristallo.

Grazie al peso del cristallo il piano viene solo appoggiato sulla base e non necessita di fissaggio.

## NOTE TECNICHE SUI MATERIALI

**CRISTALLO** | Le finiture esclusive risultato della lavorazione manuale realizzata sul cristallo possono presentare striature e differenze cromatiche. Queste caratteristiche non devono essere considerate difetti ma elementi distintivi del processo artigianale che esaltano la bellezza e la peculiarità del pezzo unico.

Table with 15mm glass top painted with the exclusive "Cashmere" brushed finish in the colours gold grey or anthracite. Also available in the exclusive finish antique bronze or lead. Large bevel of 60mm on all the top edges. Wooden base covered by 6mm tempered painted glass in the same finish of the top.

! The company reserves the right to choose the colour of the metal beam, matching it with the glass finish.

Thanks to the weight of the glass, the top is only placed on the base and does not need to be fixed.

## TECHNICAL INFORMATION ON THE MATERIALS

**GLASS** | Exclusive finishes, resulting from the craftsmanship on the glass, may show streaks and chromatic differences. These characteristics should not be considered imperfections but distinctive evidence of the hand-made process that enhance the beauty and peculiarity of the unique piece.



## Cm

200 x 90 x 74  
200 x 100 x 74  
240 x 90 x 74  
240 x 100 x 74  
280 x 110 x 74

## Inches

78¾" x 35½" x 29¼"  
78¾" x 39½" x 29¼"  
94½" x 35½" x 29¼"  
94½" x 39½" x 29¼"  
110¼" x 43½" x 29¼"

[For technical drawing / p. 81](#)

[Pricelist 2023 / p. 13](#)  
[Homescapes, sense of materials / p. 51](#)  
[Homescapes, gentle attitude / p. 45](#)

▲ **DOLM PLUS**  
Piano in cristallo verniciato "Cashmere" gold grey  
"Cashmere" gold grey painted glass top



Cristallo verniciato  
"Cashmere" gold grey  
"Cashmere" gold grey  
painted glass



Cristallo verniciato  
"Cashmere" anthracite  
"Cashmere" anthracite  
painted glass



Cristallo verniciato  
Bronzo antico  
Antique bronze  
painted glass



Cristallo verniciato  
Piombo  
Lead painted glass



# Eros

Pierangelo Gallotti / 1971

Tavolo in cristallo trasparente o extralight 15mm. Parti metalliche cromate. Basamento in cristallo temperato. Su richiesta si realizzano piani con dimensioni speciali.

! Per piani di dimensioni superiori a 240cm sono previste 2 basi.

Grazie al peso del cristallo il piano viene solo appoggiato sulla base e non necessita di fissaggio.

Table in 15mm transparent or extralight glass. Chromed metal parts. Tempered glass base. Customised sizes for the top on request.

! For glass top larger than 240cm, 2 bases are provided.

Thanks to the weight of the glass, the top is only placed on the base and does not need to be fixed.



Cm	Inches
○ Ø 120 x 74	Ø 47 1/4" x 29 1/4"
○ Ø 130 x 74	Ø 51 1/4" x 29 1/4"
○ Ø 140 x 74	Ø 55 1/4" x 29 1/4"
○ Ø 150 x 74	Ø 59 1/4" x 29 1/4"
○ Ø 160 x 74	Ø 63" x 29 1/4"
□ 240 x 120 x 74	94 1/2" x 47 1/4" x 29 1/4"
□ 240 x 120 x 74	94 1/2" x 47 1/4" x 29 1/4"
□ Piano spessore 19mm	Top thickness 19mm
□ 260 x 120 x 74	102 1/2" x 47 1/4" x 29 1/4"
□ 280 x 120 x 74	110 1/4" x 47 1/4" x 29 1/4"
□ 300 x 120 x 74	118 1/4" x 47 1/4" x 29 1/4"
○ 260 x 120 x 74	102 1/2" x 47 1/4" x 29 1/4"
○ 280 x 120 x 74	110 1/4" x 47 1/4" x 29 1/4"
○ 300 x 120 x 74	118 1/4" x 47 1/4" x 29 1/4"

For technical drawing / p. 81

Pricelist 2023 / p. 14  
Homescapes, gentle attitude / p. 90

## PIANO/TOP



Cristallo trasparente  
Transparent glass



Cristallo extralight  
Extralight glass

## PARTI METALLICHE / METAL PARTS



Metallo cromato  
Chromed metal



▲ EYL  
Piano in cristallo retroverniciato liquirizia satinato  
Satin liquorice painted glass top

# Eyl

Oscar e Gabriele Buratti / 2014

Tavolo con piano in cristallo 15mm retroverniciato nei colori del campionario, nella versione brillante o satinata. Piano con bisello 25mm. Base in legno rivestito in cristallo 6mm temperato retroverniciato nella stessa finitura del piano. Parti metalliche in acciaio inox lucido "supermirror". Disponibile anche versione in cristallo verniciato bronzo patinato (escluso per piani cm 280/300).

! Grazie al peso del cristallo il piano viene solo appoggiato sulla base e non necessita di fissaggio.

#### NOTE TECNICHE SUI MATERIALI

**CRISTALLO - BRONZO PATINATO** | Le finiture esclusive risultato della lavorazione manuale realizzata sul cristallo possono presentare striature e differenze cromatiche. Queste caratteristiche non devono essere considerate difetti ma elementi distintivi del processo artigianale che esaltano la bellezza e la peculiarità del pezzo unico.

Table with 15mm painted glass top as per samples in the bright or satin version. Glass top with 25mm bevelled edge. Wooden base covered by 6mm tempered painted glass in the same finish of the top. "Supermirror" bright stainless steel metal parts. Also available version with patinated bronze painted glass (excluding for glass tops cm 280/300).

! Thanks to the weight of the glass, the top is only placed on the base and does not need to be fixed.

#### TECHNICAL INFORMATION ON THE MATERIALS

**GLASS - PATINATED BRONZE** | Exclusive finishes, resulting from the craftsmanship on the glass, may show streaks and chromatic differences. These characteristics should not be considered imperfections but distinctive evidence of the hand-made process that enhance the beauty and peculiarity of the unique piece.



#### Cm

150 x 150 x 75  
210 x 130 x 75  
240 x 130 x 75  
260 x 130 x 75  
280 x 140 x 75  
300 x 140 x 75

#### Inches

59¼" x 59¼" x 29¾"  
82¾" x 51¼" x 29¾"  
94½" x 51¼" x 29¾"  
102½" x 51¼" x 29¾"  
110¼" x 55¼" x 29¾"  
118¼" x 55¼" x 29¾"

For technical drawing / p. 81

Pricelist 2023 / p. 15

#### PIANO/TOP



Sample box

**Cristallo brillante/satinato**  
nei colori del campionario  
Bright/satin painted glass  
version as per samples



**Bronzo patinato**  
Patinated bronze

#### PARTI METALLICHE/METAL PARTS



**Acciaio inox lucido**  
"supermirror"  
"Supermirror" bright  
stainless steel

# Haumea - T

Massimo Castagna / 2016

Tavolo con piano in cristallo trasparente temperato 15mm. Base in frassino tinto nero poro aperto, bianco poro aperto o laccato ruggine. Cilindro centrale in metallo ottonato lucido, brunito a mano, ramato, cromato nero, laccato bianco o nichelato lucido. Ciotola disponibile in ottone lucido, ottone cromato nero, ottone nichelato lucido o ottone laccato bianco. Vassoio amovibile. Disponibile nelle combinazioni sotto elencate. Su richiesta piano in cristallo "grigio Italia" temperato 12mm. Disponibile su richiesta versione lounge cm 65h.

! Per piani di dimensioni superiori a 260cm sono previste due basi.

Versione con due basi: grazie al peso del cristallo il piano viene solo appoggiato sulla base e non necessita di fissaggio.

## NOTE TECNICHE SUI MATERIALI

**OTTONE BRUNITO A MANO** | L'ottone brunito a mano è ottenuto da un processo di ossidazione naturale eseguito manualmente. Il risultato di questa lavorazione è un prodotto che può presentare macchie e variazioni di colore che non sono da considerarsi imperfezioni ma caratteristiche che conferiscono ad ogni pezzo una particolare unicità, rendendolo esclusivo.

Table with 15mm transparent tempered glass top. Black or white open pore stained ash or rust lacquered wooden base. Central cylinder in bright brass-plated, hand burnished, copper-plated, black chromed, white lacquered or bright nickel-plated metal. Bowl available in bright brass, black chromed brass, bright nickel-plated brass or white lacquered brass. Removable tray. Available in the combinations as per our list below. 12mm smoked "grigio Italia" tempered glass top, on request. Lounge version height cm 65, available on request.

! For glass top larger than 260cm, two bases are provided.

Version with two bases: thanks to the weight of the glass, the top is only placed on the base and does not need to be fixed.

## TECHNICAL INFORMATION ON THE MATERIALS

**HAND BURNISHED BRASS** | The hand burnished brass is the consequence of hand-made process of natural oxidation. The result of this processing is a product that may show marks and colour variations. These differences are inevitable and should not be considered imperfections but evidence of the hand-crafted process. They enhance the beauty and distinctiveness of a unique piece.



### Cm

Ø 150 x 65 (lounge)  
Ø 160 x 65 (lounge)  
Ø 180 x 65 (lounge)

Ø 150 x 74  
Ø 160 x 74  
Ø 180 x 74

### Inches

Ø 59¼" x 25¾"  
Ø 63" x 25¾"  
Ø 71" x 25¾"

Ø 59¼" x 29¼"  
Ø 63" x 29¼"  
Ø 71" x 29¼"

### Cm

180 x 110 x 65 (lounge)  
210 x 110 x 65 (lounge)  
230 x 110 x 65 (lounge)

260 x 130 x 65 (lounge)  
280 x 130 x 65 (lounge)  
300 x 130 x 65 (lounge)

180 x 110 x 74  
210 x 110 x 74  
230 x 110 x 74

260 x 130 x 74  
280 x 130 x 74  
300 x 130 x 74

### Inches

71" x 43½" x 25¾"  
82¾" x 43½" x 25¾"  
90¾" x 43½" x 25¾"

102½" x 51¼" x 25¾"  
110¼" x 51¼" x 25¾"  
118¼" x 51¼" x 25¾"

71" x 43½" x 29¼"  
82¾" x 43½" x 29¼"  
90¾" x 43½" x 29¼"

102½" x 51¼" x 29¼"  
110¼" x 51¼" x 29¼"  
118¼" x 51¼" x 29¼"

For technical drawing / p. 82

Pricelist 2023 / p. 16

## COMBINAZIONI COMBINATIONS

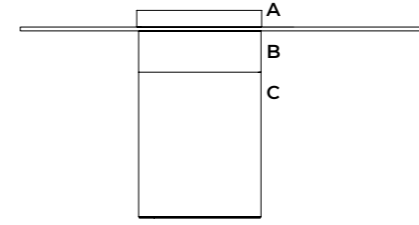

### COMB. 1

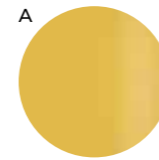

Ottone lucido  
Bright brass

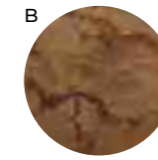

Ottone brunito a mano  
Hand burnished brass

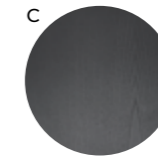

Frassino tinto nero a poro aperto  
Black open pore stained ash

### PIANO/TOP



Cristallo trasparente  
o "grigio Italia"  
Transparent or smoked  
"grigio Italia" glass

### COMB. 2

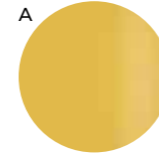

Ottone lucido  
Bright brass

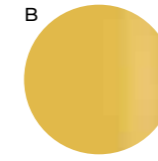

Ottone lucido  
Bright brass

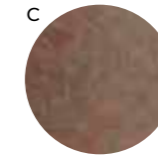

Ruggine  
Rust

### PIANO/TOP



Cristallo trasparente  
o "grigio Italia"  
Transparent or smoked  
"grigio Italia" glass

### COMB. 3

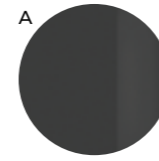

Ottone cromato nero  
Black chromed brass

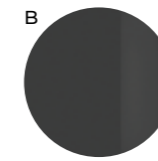

Ottone cromato nero  
Black chromed brass

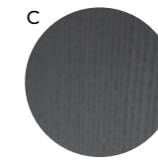

Frassino tinto nero a poro aperto  
Black open pore stained ash

### PIANO/TOP



Cristallo trasparente  
o "grigio Italia"  
Transparent or smoked  
"grigio Italia" glass

### COMB. 4

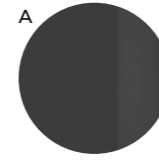

Ottone cromato nero  
Black chromed brass

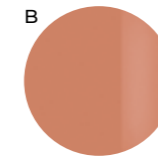

Ottone ramato  
Coppered brass

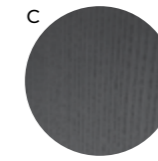

Frassino tinto nero a poro aperto  
Black open pore stained ash

### PIANO/TOP



Cristallo trasparente  
o "grigio Italia"  
Transparent or smoked  
"grigio Italia" glass

### COMB. 5

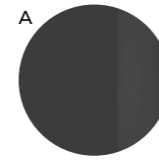

Ottone cromato nero  
Black chromed brass

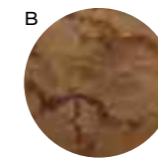

Ottone brunito a mano  
Hand burnished brass

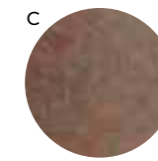

Ruggine  
Rust

### PIANO/TOP



Cristallo trasparente  
o "grigio Italia"  
Transparent or smoked  
"grigio Italia" glass

### COMB. 6

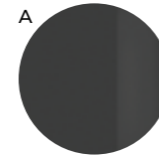

Ottone cromato nero  
Black chromed brass

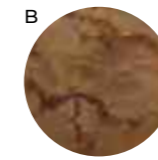

Ottone brunito a mano  
Hand burnished brass

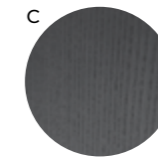

Frassino tinto nero a poro aperto  
Black open pore stained ash

### PIANO/TOP



Cristallo trasparente  
o "grigio Italia"  
Transparent or smoked  
"grigio Italia" glass

### COMB. 7

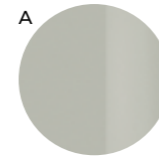

Ottone nichelato lucido  
Bright nickel-plated brass

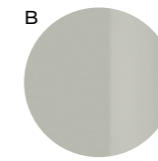

Metallo nichelato lucido  
Bright nickel-plated metal

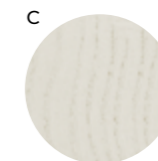

Frassino tinto "Pure" bianco poro aperto  
"Pure" white open pore stained ash

### PIANO/TOP



Cristallo trasparente  
o "grigio Italia"  
Transparent or smoked  
"grigio Italia" glass

### COMB. 8



Ottone laccato bianco opaco  
Mat white lacquered brass



Metallo laccato bianco lucido  
Glossy white lacquered metal

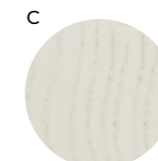

Frassino tinto "Pure" bianco poro aperto  
"Pure" white open pore stained ash

### PIANO/TOP



Cristallo trasparente  
o "grigio Italia"  
Transparent or smoked  
"grigio Italia" glass



▲ HAUMEA - T  
Combinazione 1: Piano in cristallo trasparente temperato / Base in frassino tinto nero a poro aperto / Ottone brunito / Vassoio in ottone lucido  
Combination 1: Transparent tempered glass top / Black open pore stained ash base / Burnished brass / Bright brass tray



# Maat

Pietro Russo / 2017

Tavolo con struttura in alluminio spazzolato a mano e anodizzato nero. Dettagli in ottone lucido. Piano in marmo lucido naturale Bianco Statuario e Nero Marquinia stratificato e bisellato. Su richiesta realizzabile con piano in legno intarsiato con motivo "Tweed" o piano in cristallo 15mm retroverniciato nei colori del campionario nella versione brillante o satinata e bisello da 35mm. Disponibile versione con piano in cristallo 15mm verniciato nella finitura esclusiva bronzo antico e piombo con bisello da 35mm e struttura in alluminio e dettagli nella stessa finitura del piano.

! Versione con piano in cristallo: grazie al peso del cristallo il piano viene solo appoggiato sulla base e non necessita di fissaggio.

## NOTE TECNICHE SUI MATERIALI

**MARMO** | Il marmo è un materiale naturale di origine sedimentaria che può presentare particolarità come venature, lievi irregolarità superficiali, colorazioni differenti e cristallizzazioni. Queste peculiarità sono da attribuirsi alla naturalezza del materiale e non sono da considerarsi difetti ma caratteristiche tipiche del marmo. Ogni prodotto risulterà unico, esclusivo e non replicabile.

I nostri marmi vengono trattati con un prodotto idrorepellente che permette una maggiore protezione della superficie stessa, aumentando l'impermeabilità. Questo trattamento non esclude la vulnerabilità del marmo alle sostanze acide.

**CRISTALLO** | Le finiture esclusive risultato della lavorazione manuale realizzata sul cristallo possono presentare striature e differenze cromatiche. Queste caratteristiche non devono essere considerate difetti ma elementi distintivi del processo artigianale che esaltano la bellezza e la peculiarità del pezzo unico.

**INTARSIO** | L'intarsio è una tecnica di lavorazione artigianale utilizzata per ottenere un particolare disegno e si realizza accostando elementi di materiali differenti (come legno e alluminio) oppure dello stesso materiale. Questa lavorazione rende il prodotto unico ed esclusivo. Le eventuali variazioni cromatiche e di venatura del legno sono da considerarsi caratteristiche del materiale stesso e non possono essere controllate.

Table with black hand brushed anodised aluminium structure. Bright brass details. Natural polished Bianco Statuario and Nero Marquinia marble laminated bevelled top. Also available in inlaid wooden top with "Tweed" pattern. 15mm painted glass top as per samples in the bright or satin version with 35mm bevel, on request. Available version with 15mm glass top painted in the exclusive antique bronze and lead finish with 35mm bevel and aluminum structure and details in the same finish of the glass top.

! Glass version top: thanks to the weight of the glass, the top is only placed on the base and does not need to be fixed.

## TECHNICAL INFORMATION ON THE MATERIALS

**MARBLE** | The marble is a natural material of sedimentary origin that can present particularities such as veins, slight surface irregularities, different colors and crystallizations. These peculiarities are to be attributed to the naturalness of the material and are not to be considered defects but typical characteristics of marble. Each product will be unique, exclusive and non-replicable.

Our marbles are treated with water-repellent products which affords greater protection to the surface of the marble, improving its impermeability. This treatment doesn't exclude the vulnerability of the marble to acid substances.

**GLASS** | Exclusive finishes, resulting from the craftsmanship on the glass, may show streaks and chromatic differences. These characteristics should not be considered imperfections but distinctive evidence of the hand-made process that enhance the beauty and peculiarity of the unique piece.

**INLAY** | Inlay is an artisanal technique used to obtain a particular design and is made by combining elements of different materials (such as wood and aluminium) or of the same material. This process makes the product unique and exclusive. Any colour and grain variations of the wood are to be considered as characteristics of the material itself and cannot be controlled.

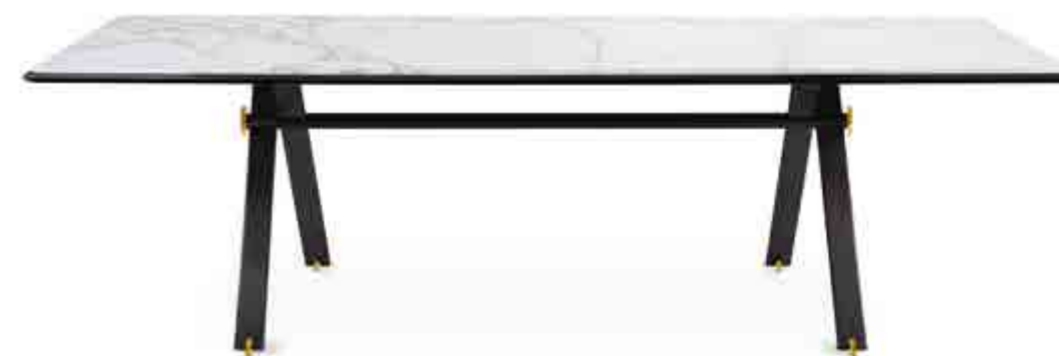

### Cm Marmo

220 x 100 x 75,5  
250 x 100 x 75,5  
280 x 100 x 75,5

### Legno intarsiato

220 x 100 x 76  
250 x 100 x 76  
280 x 100 x 76

### Inches Marble

86¾" x 39½" x 29¾"  
98½" x 39½" x 29¾"  
110¼" x 39½" x 29¾"

### Inlaid wood

86¾" x 39½" x 30"  
98½" x 39½" x 30"  
110¼" x 39½" x 30"

### Cm Cristallo

220 x 100 x 74,5  
250 x 100 x 74,5  
280 x 100 x 74,5

### Inches Glass

86¾" x 39½" x 29½"  
98½" x 39½" x 29½"  
110¼" x 39½" x 29½"

For technical drawing / p. 82

Pricelist 2023 / p. 18  
Homescapes, intimate portraits / p. 74, 77

## PIANO/TOP



Marmo Bianco Statuario/  
Nero Marquinia  
lucido naturale  
Bianco Statuario/  
Nero Marquinia marble  
natural polished



Legno intarsiato con  
motivo "Tweed"  
Inlaid wood  
with "Tweed" pattern



Sample box

Cristallo brillante/satinato  
nei colori del campionario  
Glass bright/satin version  
as per samples

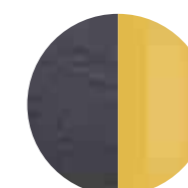

Alluminio spazzolato nero/  
ottone lucido  
Black brushed aluminium/  
Bright brass

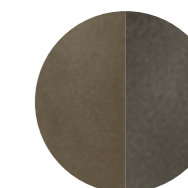

Bronzo antico / Piombo  
Antique bronze / Lead

▲ MAAT  
Piano in Marmo Bianco Statuario e Nero Marquinia  
Bianco Statuario and Nero Marquinia marble top



• MAAT  
Piano in legno intarsiato con motivo "Tweed"  
Inlaid wooden top with "Tweed" pattern





▲ MANTO  
Piano in legno intarsiato Noce "Colore" Frisé con bisello nero  
Top in "Colore" Frisé Walnut wood inlay and black bevelled edge

# Manto

Pietro Russo / 2020

Tavolo con piano in legno Noce "Colore" Frisé intarsiato a spina di pesce con bisello da 60mm in colore nero. Disponibile anche con piano intarsiato in Noce "Colore" Frisé o Acero Frisé grigio scuro con bisello da 60mm nella stessa finitura. Base curvata con bottone in ottone lucido. Disponibile versione "total color" con piano e base curvata in legno con bottone in metallo laccati lucido nei colori "Bianco Camargue", "Sabbia del Nilo", "Rosa Jaipur", "Rosso Persia", "Bordeaux Etruria", "Verde Provenza", "Blu Pacifico", "Grigio Londra", "Nero Giza". Lazy Susan in appoggio, su richiesta, disponibile nella stessa finitura del piano.

Il legno è un materiale vivo che subisce un naturale processo di ossidazione che può causare cambiamenti cromatici. Venature e tonalità di colore differenti delle lastre non sono da considerarsi come difetti, ma caratteristiche che esaltano l'unicità del materiale.

#### NOTE TECNICHE SUI MATERIALI

**INTARSIO** | L'intarsio è una tecnica di lavorazione artigianale utilizzata per ottenere un particolare disegno e si realizza accostando elementi di materiali differenti (come legno e alluminio) oppure dello stesso materiale. Questa lavorazione rende il prodotto unico ed esclusivo. Le eventuali variazioni cromatiche e di venatura del legno sono da considerarsi caratteristiche del materiale stesso e non possono essere controllate.

Table with top in "Colore" Frisé Walnut herringbone wood inlay and 60mm black bevelled edge. Also available with inlay top in "Colore" Frisé Walnut or dark grey Frisé Maple with 60mm bevelled edge in the same finish. Curved base with bright brass button. Available version "total color" with top and curved base with metal button glossy lacquered in the colours "Bianco Camargue", "Sabbia del Nilo", "Rosa Jaipur", "Rosso Persia", "Bordeaux Etruria", "Verde Provenza", "Blu Pacifico", "Grigio Londra", "Nero Giza".

Resting Lazy Susan on request, available in the same finish of the top.

Wood is a living material and the natural oxidation process can cause chromatic changes. Different grain and colour shades of the wooden slabs are not to be considered as defects, but characteristics that enhance the uniqueness of the material.

#### TECHNICAL INFORMATION ON THE MATERIALS

**INLAY** | Inlay is an artisanal technique used to obtain a particular design and is made by combining elements of different materials (such as wood and aluminium) or of the same material. This process makes the product unique and exclusive. Any colour and grain variations of the wood are to be considered as characteristics of the material itself and cannot be controlled.



#### Cm

Ø 150 x 73  
Ø 180 x 73

#### Lazy Susan

Ø 70 (Ø 150 x 73)  
Ø 100 (Ø 180 x 73)

#### Inches

Ø 59¼" x 28¾"  
Ø 71" x 28¾"

#### Lazy Susan

Ø 27¾" (Ø 59¼" x 28¾")  
Ø 39½" (Ø 71" x 28¾")

For technical drawing / p. 83

Pricelist 2023 / p. 19  
Homescapes, embracing beauty / p. 75

#### PIANO/TOP



Legno Noce "Colore" Frisé con bisello nero  
"Colore" Frisé Walnut wood with black bevelled edge



Legno Noce "Colore" Frisé "Colore" Frisé Walnut wood



Legno Acero Frisé grigio scuro  
Maple Frisé dark grey wood

#### BOTTONE/BUTTON

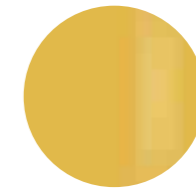

Ottone lucido  
Bright brass

#### VERSIONE "TOTAL COLOR" / "TOTAL COLOR" VERSION

#### PIANO/BASE LEGNO E BOTTONE METALLO WOODEN TOP/BASE AND METAL BUTTON

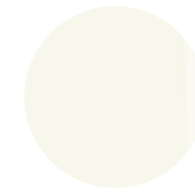

Laccato lucido "Bianco Camargue"  
Glossy lacquered "Bianco Camargue"



Laccato lucido "Sabbia del Nilo"  
Glossy lacquered "Sabbia del Nilo"



Laccato lucido "Rosa Jaipur"  
Glossy lacquered "Rosa Jaipur"

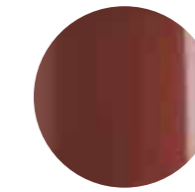

Laccato lucido "Rosso Persia"  
Glossy lacquered "Rosso Persia"

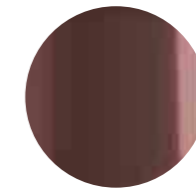

Laccato lucido "Bordeaux Etruria"  
Glossy lacquered "Bordeaux Etruria"



Laccato lucido "Verde Provenza"  
Glossy lacquered "Verde Provenza"

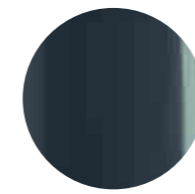

Laccato lucido "Blu Pacifico"  
Glossy lacquered "Blu Pacifico"

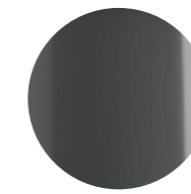

Laccato lucido "grigio Londra"  
Glossy lacquered "Grigio Londra"



Laccato lucido "Nero Giza"  
Glossy lacquered "Nero Giza"



• MANTO  
Piano in legno intarsiato Acero Frisé grigio scuro con lazy susan  
Top in Maple Frisé dark grey wood inlay with lazy susan



• MANTO  
Piano in legno intarsiato Noce "Colore" Frisé con lazy susan  
Top in "Colore" Frisé Walnut wood inlay with lazy susan



• MANTO  
Versione "total color" Bordeaux Etruria laccato lucido  
Bordeaux Etruria glossy lacquered "total color" version







# Manto Oval

Pietro Russo / 2021

Tavolo con piano in legno Noce "Colore" Frisé intarsiato con bisello da 40mm in colore nero. Base curvata con bottone in ottone lucido.

! Il legno è un materiale vivo che subisce un naturale processo di ossidazione che può causare cambiamenti cromatici. Venature e tonalità di colore differenti delle lastre non sono da considerarsi come difetti, ma caratteristiche che esaltano l'unicità del materiale.

#### NOTE TECNICHE SUI MATERIALI

**INTARSIO** | L'intarsio è una tecnica di lavorazione artigianale utilizzata per ottenere un particolare disegno e si realizza accostando elementi di materiali differenti (come legno e alluminio) oppure dello stesso materiale. Questa lavorazione rende il prodotto unico ed esclusivo. Le eventuali variazioni cromatiche e di venatura del legno sono da considerarsi caratteristiche del materiale stesso e non possono essere controllate.

Table with top in "Colore" Frisé walnut wood inlay with 40mm black bevelled edge. Curved base with bright brass button.

! Wood is a living material and the natural oxidation process can cause chromatic changes. Different grain and colour shades of the wooden slabs are not to be considered as defects, but characteristics that enhance the uniqueness of the material.

#### TECHNICAL INFORMATION ON THE MATERIALS

**INLAY** | Inlay is an artisanal technique used to obtain a particular design and is made by combining elements of different materials (such as wood and aluminium) or of the same material. This process makes the product unique and exclusive. Any colour and grain variations of the wood are to be considered as characteristics of the material itself and cannot be controlled.



#### Cm

240 x 110 x 73  
280 x 110 x 73  
300 x 110 x 73

#### Inches

94½" x 43½" x 28¾"  
110¼" x 43½" x 28¾"  
118¼" x 43½" x 28¾"

[For technical drawing / p. 83](#)

[Pricelist 2023 / p. 20](#)  
[Homescapes, intimate portraits / pp. 40, 46](#)

#### PIANO/TOP



Legno Noce "Colore" Frisé  
con bisello nero  
"Colore" Frisé Walnut wood  
with black beveled edge

#### DETTAGLI/DETAILS



Ottone lucido  
Bright brass



• MOLECOLA  
 Legno spatolato a mano "Mattone"  
 Hand spatulated wood "Brick"

# Molecola

Massimo Castagna / 2024

Tavolo con piano in cristallo trasparente temperato 15mm.  
 Base formata da cilindri in legno spatolati a mano.  
 Disponibile nei colori mattone, corda, carbone o avorio.

Table with 15mm transparent tempered glass top. Hand-brushed wooden cylinders base.  
 Available in brick, rope, charcoal or ivory colours.



Cm	Inches
○ Ø 180 x 74,5	Ø 71" x 29½"
○ Ø 200 x 74,5	Ø 78¾" x 29½"
□ 240 x 150 x 74,5	94½" x 59¼" x 29½"
□ 260 x 150 x 74,5	102½" x 59¼" x 29½"
□ 300 x 150 x 74,5	118¼" x 59¼" x 29½"
□ 320 x 150 x 74,5	126" x 59¼" x 29½"

[For technical drawing / p. 83](#)

[Pricelist 2023 / p. 20](#)  
[Homescapes, intimate portraits / pp. 40, 46](#)

## PIANO/TOP



Cristallo trasparente  
 Transparent glass

## BASE/BASE



Legno spatolato a mano  
 "Avorio"  
 Hand-spatulated wood  
 "Ivory"



Legno spatolato a mano  
 "Corda"  
 Hand-spatulated wood  
 "Rope"



Legno spatolato a mano  
 "Mattone"  
 Hand-spatulated wood  
 "Brick"



Legno spatolato a mano  
 "Carbone"  
 Hand-spatulated wood  
 "Charcoal"



• MOLECOLA  
Basi in legno spatolato a mano "Avorio"  
Hand spatulated wood base "Ivory"



• MOLECOLA  
Basi in legno spatolato a mano "Corda"  
Hand spatulated wood base "Rope"



• MOLECOLA  
Basi in legno spatolato a mano "Carbone"  
Hand spatulated wood base "Charcoal"





▲ OTO  
Piano in cristallo retroverniciato liquirizia satinato  
Satin liquorice painted glass top

# Oto

Oscar e Gabriele Buratti / 2015

Tavolo con piano in cristallo 15mm retroverniciato nei colori nero, blu grigio e liquirizia nella versione brillante o satinata. Piano con bisello 25mm. Struttura in metallo verniciato lucido. Disponibile anche nella versione con piano in cristallo e struttura in metallo verniciati bronzo patinato.

## NOTE TECNICHE SUI MATERIALI

**CRISTALLO** | Le finiture esclusive risultato della lavorazione manuale realizzata sul cristallo possono presentare striature e differenze cromatiche. Queste caratteristiche non devono essere considerate difetti ma elementi distintivi del processo artigianale che esaltano la bellezza e la peculiarità del pezzo unico.

Table with 15 mm bevelled and painted glass top in the colours black, blue grey and liquorice in the bright or satin version. Top with 25mm bevel. Bright lacquered metal structure. Also available with patinated bronze painted glass top and metal structure.

## TECHNICAL INFORMATION ON THE MATERIALS

**GLASS** | Exclusive finishes, resulting from the craftsmanship on the glass, may show streaks and chromatic differences. These characteristics should not be considered imperfections but distinctive evidence of the hand-made process that enhance the beauty and peculiarity of the unique piece.



## Cm

Ø 90 x 74  
Ø 100 x 74  
Ø 120 x 74  
Ø 130 x 74  
Ø 140 x 74  
Ø 150 x 74

## Inches

Ø 35½" x 29¼"  
Ø 39½" x 29¼"  
Ø 47¼" x 29¼"  
Ø 51¼" x 29¼"  
Ø 55¼" x 29¼"  
Ø 59¼" x 29¼"

For technical drawing / p. 84

Pricelist 2023 / p. 21

## PIANO E STRUTTURA/TOP AND STRUCTURE

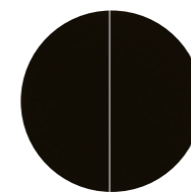

**Cristallo retroverniciato nero brillante/satinato**  
Bright/satin black painted glass

**Metallo verniciato nero lucido**  
Bright black lacquered metal

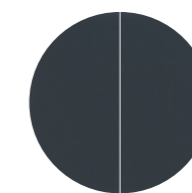

**Cristallo retroverniciato blu grigio brillante/satinato**  
Bright/satin blue grey painted glass

**Metallo verniciato blu grigio lucido**  
Bright blue grey lacquered metal



**Cristallo retroverniciato liquirizia brillante/satinato**  
Bright/satin liquorice painted glass

**Metallo verniciato liquirizia lucido**  
Bright liquorice lacquered metal

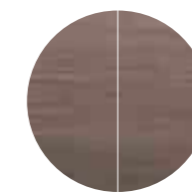

**Cristallo verniciato bronzo patinato**  
Patinated bronze painted glass

**Metallo verniciato bronzo patinato**  
Patinated bronze lacquered metal



▲ **OTO BIG**  
Piano e base in marmo lucido naturale Bianco Carrara Gioia  
Top and base in natural polished Bianco Carrara Gioia marble

# Oto Big

Oscar e Gabriele Buratti / 2018

Tavolo con piano e base in marmo Bianco Carrara Gioia lucido naturale oppure nella versione in marmo Nero Marquinia levigato opaco. Piatto a terra in metallo ottonato lucido. Su richiesta piano girevole in appoggio in marmo nella stessa finitura del piano.

! Diametro massimo realizzabile 180cm / 71"

## NOTE TECNICHE SUI MATERIALI

**MARMO** | Il marmo è un materiale naturale di origine sedimentaria che può presentare particolarità come venature, lievi irregolarità superficiali, colorazioni differenti e cristallizzazioni. Queste peculiarità sono da attribuirsi alla naturalezza del materiale e non sono da considerarsi difetti ma caratteristiche tipiche del marmo. Ogni prodotto risulterà unico, esclusivo e non replicabile. I nostri marmi vengono trattati con un prodotto idrorepellente che permette una maggiore protezione della superficie stessa, aumentando l'impermeabilità. Questo trattamento non esclude la vulnerabilità del marmo alle sostanze acide.

Table with top and base in natural polished Bianco Carrara Gioia marble or honed mat Nero Marquinia marble. Glossy brass-plated metal bottom plate. Marble rotating plate in the same finish of the top resting on the top, on request.

! Maximum achievable diameter 180cm / 71"

## TECHNICAL INFORMATION ON THE MATERIALS

**MARBLE** | The marble is a natural material of sedimentary origin that can present particularities such as veins, slight surface irregularities, different colors and crystallizations. These peculiarities are to be attributed to the naturalness of the material and are not to be considered defects but typical characteristics of marble. Each product will be unique, exclusive and non-replicable. Our marbles are treated with water-repellent products which affords greater protection to the surface of the marble, improving its impermeability. This treatment doesn't exclude the vulnerability of the marble to acid substances.



**Cm**  
Ø 160 x 73  
Ø 180 x 73

**Lazy Susan**  
Ø 80 (Ø160 x 73)  
Ø 100 (Ø180 x 73)

**Inches**  
Ø 63" x 28¾"  
Ø 71" x 28¾"

**Lazy Susan**  
Ø 31½" (Ø63" x 28¾")  
Ø 39½" (Ø71" x 28¾")

[For technical drawing / p. 84](#)

[Pricelist 2023 / p. 22](#)  
[Homescapes, intimate portraits / p. 29](#)

## PIANO E BASE/TOP AND BASE



Marmo lucido naturale  
**Bianco Carrara Gioia**  
Natural polished  
Bianco Carrara Gioia marble



Marmo levigato opaco  
**Nero Marquinia**  
Honed mat  
Nero Marquinia marble

## PIATTO A TERRA/BOTTOM PLATE

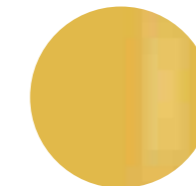

Metallo ottonato lucido  
Glossy brass-plated metal

# Oto Medium

Oscar e Gabriele Buratti / 2022

Tavolo con piano in marmo 20mm Bianco Carrara Gioia lucido naturale e struttura in metallo verniciato bronzo antico. Disponibile versione con piano in marmo 20mm Nero Marquinia levigato opaco e struttura in metallo verniciato piombo.

! Diametro massimo realizzabile 150cm / 59¼"

## NOTE TECNICHE SUI MATERIALI

**MARMO** | Il marmo è un materiale naturale di origine sedimentaria che può presentare particolarità come venature, lievi irregolarità superficiali, colorazioni differenti e cristallizzazioni. Queste peculiarità sono da attribuirsi alla naturalezza del materiale e non sono da considerarsi difetti ma caratteristiche tipiche del marmo. Ogni prodotto risulterà unico, esclusivo e non replicabile. I nostri marmi vengono trattati con un prodotto idrorepellente che permette una maggiore protezione della superficie stessa, aumentando l'impermeabilità. Questo trattamento non esclude la vulnerabilità del marmo alle sostanze acide.

Table with 20mm natural polished Bianco Carrara Gioia marble and antique bronze lacquered metal structure. Available version with 20mm honed mat Nero Marquinia marble and lead lacquered metal structure.

! Maximum achievable diameter 150cm / 59¼"

## TECHNICAL INFORMATION ON THE MATERIALS

**MARBLE** | The marble is a natural material of sedimentary origin that can present particularities such as veins, slight surface irregularities, different colors and crystallizations. These peculiarities are to be attributed to the naturalness of the material and are not to be considered defects but typical characteristics of marble. Each product will be unique, exclusive and non-replicable. Our marbles are treated with water-repellent products which affords greater protection to the surface of the marble, improving its impermeability. This treatment doesn't exclude the vulnerability of the marble to acid substances.



### Cm

Ø 130 x 73  
Ø 140 x 73  
Ø 150 x 73

### Inches

Ø 51¼" x 28¾"  
Ø 55¼" x 28¾"  
Ø 59¼" x 28¾"

[For technical drawing / p. 84](#)

[Pricelist 2023 / p. 23](#)

### PIANO/TOP

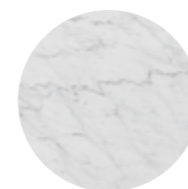

Marmo lucido naturale  
Bianco Carrara Gioia  
Natural polished  
Bianco Carrara Gioia marble

### STRUTTURA/STRUCTURE



Metallo verniciato  
bronzo antico  
Antique bronze  
lacquered metal

### PIANO/TOP



Marmo levigato opaco  
Nero Marquinia  
Honed mat  
Nero Marquinia marble

### STRUTTURA/STRUCTURE

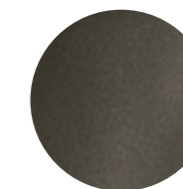

Metallo verniciato  
piombo  
Lead lacquered metal

### ▲ OTO MEDIUM

Piano in marmo lucido naturale Bianco Carrara Gioia / Struttura in metallo verniciato bronzo antico  
Top in natural polished Bianco Carrara Gioia marble / Antique bronze lacquered metal structure.



▲ **PLATIUM**  
Piano in cristallo retroverniciato nero brillante / Base in marmo lucido naturale Sahara Noir  
Bright black painted glass top / Natural polished Sahara Noir marble base

# Platium

Oscar e Gabriele Buratti / 2016

Tavolo con piano in cristallo 15mm retroverniciato nero nella versione brillante e satinata. Importante bisellatura di 40mm su due lati del piano. Base in legno rivestito in marmo lucido naturale 20mm Sahara Noir e piatto a terra in acciaio inox lucido "supermirror". Disponibile anche nella versione con piano in cristallo 15mm e base in legno rivestito in cristallo 6mm retroverniciato nei colori nero, blue grigio o liquirizia, nella versione brillante o satinata oppure verniciata nella finitura esclusiva spazzolata "Cashmere" gold grey o anthracite.

! Grazie al peso del cristallo il piano viene solo appoggiato sulla base e non necessita di fissaggio.

## NOTE TECNICHE SUI MATERIALI

**CRISTALLO** | Le finiture esclusive risultato della lavorazione manuale realizzata sul cristallo possono presentare striature e differenze cromatiche. Queste caratteristiche non devono essere considerate difetti ma elementi distintivi del processo artigianale che esaltano la bellezza e la peculiarità del pezzo unico.

**MARMO** | Il marmo è un materiale naturale di origine sedimentaria che può presentare particolarità come venature, lievi irregolarità superficiali, colorazioni differenti e cristallizzazioni. Queste peculiarità sono da attribuirsi alla naturalezza del materiale e non sono da considerarsi difetti ma caratteristiche tipiche del marmo. Ogni prodotto risulterà unico, esclusivo e non replicabile.

Table with 15mm black painted glass top in the bright or satin version. 40mm bevelled edges on two sides of the top. Wooden base covered with 20mm natural polished Sahara Noir marble and "supermirror" bright stainless steel bottom plate. Also available with 15mm glass top and wooden base covered with 6mm painted glass in the colours black, blue grey or liquorice, in the bright or satin version or painted with the exclusive "Cashmere" brushed finish in the colours gold grey or anthracite.

! Thanks to the weight of the glass, the top is only placed on the base and does not need to be fixed.

## TECHNICAL INFORMATION ON THE MATERIALS

**GLASS** | Exclusive finishes, resulting from the craftsmanship on the glass, may show streaks and chromatic differences. These characteristics should not be considered imperfections but distinctive evidence of the hand-made process that enhance the beauty and peculiarity of the unique piece.

**MARBLE** | The marble is a natural material of sedimentary origin that can present particularities such as veins, slight surface irregularities, different colors and crystallizations. These peculiarities are to be attributed to the naturalness of the material and are not to be considered defects but typical characteristics of marble. Each product will be unique, exclusive and non-replicable.



## Cm

260 x 120 x 74  
280 x 120 x 74  
300 x 120 x 74

## Inches

102½" x 47¼" x 29¼"  
110¼" x 47¼" x 29¼"  
118¼" x 47¼" x 29¼"

[For technical drawing / p. 85](#)

[Pricelist 2023 / p. 24](#)  
[Homescapes, embracing beauty / p. 15](#)

## PIANO/TOP

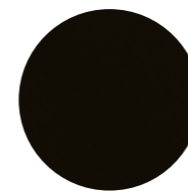

Cristallo retroverniciato  
nero brillante/satinato  
Bright/satin black painted  
glass

## BASE/BASE



Marmo lucido naturale  
Sahara Noir  
Natural polished  
Sahara Noir marble

## PIANO E BASE / TOP AND BASE

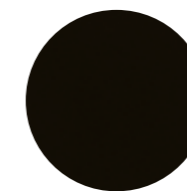

Cristallo retroverniciato  
nero brillante/satinato  
Bright/satin black  
painted glass

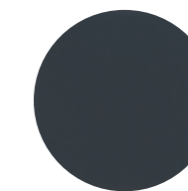

Cristallo retroverniciato  
blu grigio brillante/satinato  
Bright/satin blue-grey  
painted glass

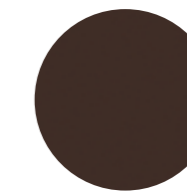

Cristallo retroverniciato  
liquirizia brillante/satinato  
Bright/satin liquorice black  
painted glass

## PIANO A TERRA / BOTTOM PLATE

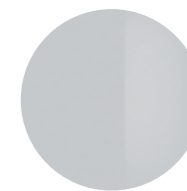

Acciaio inox lucido  
"supermirror"  
"Supermirror" bright  
stainless steel



Cristallo verniciato  
"Cashmere" gold grey  
"Cashmere" gold grey  
painted glass



Cristallo verniciato  
"Cashmere" anthracite  
"Cashmere" anthracite  
painted glass

# Platium Round

Oscar e Gabriele Buratti / 2018

Tavolo con piano in frassino spazzolato tinto nero. Piano girevole semi-incassato in cristallo temperato retroverniciato nero brillante 10mm con bisello da 35mm. Base in legno rivestito in marmo lucido naturale 20mm Sahara Noir. Piatto a terra in acciaio inox lucido "supermirror".

! Il piano girevole è sporgente rispetto al piano di circa 5 millimetri.

#### NOTE TECNICHE SUI MATERIALI

**MARMO** | Il marmo è un materiale naturale di origine sedimentaria che può presentare particolarità come venature, lievi irregolarità superficiali, colorazioni differenti e cristallizzazioni. Queste peculiarità sono da attribuirsi alla naturalezza del materiale e non sono da considerarsi difetti ma caratteristiche tipiche del marmo. Ogni prodotto risulterà unico, esclusivo e non replicabile.

Table with black stained brushed ash top. Semi-recessed rotating plate in 10mm tempered black bright painted glass with 35mm bevel. Wooden base covered with 20mm natural polished Sahara Noir marble base and "supermirror" bright stainless steel bottom plate.

! The rotating plate is protruding from the top by about 5 millimeters.

#### TECHNICAL INFORMATION ON THE MATERIALS

**MARBLE** | The marble is a natural material of sedimentary origin that can present particularities such as veins, slight surface irregularities, different colors and crystallizations. These peculiarities are to be attributed to the naturalness of the material and are not to be considered defects but typical characteristics of marble. Each product will be unique, exclusive and non-replicable.



#### Cm

Ø 180 x 76  
Ø 200 x 76  
Ø 220 x 76  
Ø 240 x 76

#### Inches

Ø 71" x 30"  
Ø 78¾" x 30"  
Ø 86¾" x 30"  
Ø 94½" x 30"

For technical drawing / p. 85

Pricelist 2023 / p. 25

#### PIANO/TOP

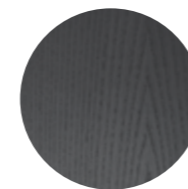

**Frassino spazzolato tinto nero**  
Black stained brushed ash

#### BASE/BASE

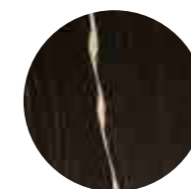

**Marmo lucido naturale Sahara Noir**  
Natural polished Sahara Noir marble

#### PIATTO A TERRA / BOTTOM PLATE



**Acciaio inox lucido "supermirror"**  
"Supermirror" bright stainless steel

#### PIANO GIREVOLE / ROTATING PLATE

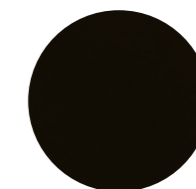

**Cristallo retroverniciato nero brillante**  
Bright black painted glass

▲ **PLATIUM ROUND**  
Piano in frassino spazzolato tinto nero / Piano girevole in cristallo retroverniciato nero brillante  
Black stained brushed ash top / Black bright painted glass rotating plate



# Platium System

Oscar e Gabriele Buratti / 2018

Tavolo con piano modulare in cristallo 15mm e base in legno rivestito in cristallo 6mm decorato a mano nella finitura esclusiva bronzo antico e piombo. Disponibile anche versione in cristallo verniciato bronzo patinato. Importante bisellatura di 40mm su due lati del piano. Dettaglio di giunzione tra i piani in ottone satinato. Piatto a terra in acciaio inox lucido "supermirror". Disponibile versione con base in legno rivestito in marmo lucido naturale 20 mm Sahara Noir, Stardust Grey o Calacatta Vagli Oro e piano in cristallo verniciato bronzo antico, piombo o bronzo patinato nelle combinazioni predefinite.

## NOTE TECNICHE SUI MATERIALI

**MARMO** | Il marmo è un materiale naturale di origine sedimentaria che può presentare particolarità come venature, lievi irregolarità superficiali, colorazioni differenti e cristallizzazioni. Queste peculiarità sono da attribuirsi alla naturalezza del materiale e non sono da considerarsi difetti ma caratteristiche tipiche del marmo. Ogni prodotto risulterà unico, esclusivo e non replicabile.

**CRISTALLO** | Le finiture esclusive risultato della lavorazione manuale realizzata sul cristallo possono presentare striature e differenze cromatiche. Queste caratteristiche non devono essere considerate difetti ma elementi distintivi del processo artigianale che esaltano la bellezza e la peculiarità del pezzo unico.

Table with 15mm modular glass top and wooden base covered by 6mm glass, decorated by hand with an exclusive finish antique bronze and lead. Also available version with patinated bronze painted glass. Large bevel of 40mm on the two sides. Junction detail between tops in satin brass. "Supermirror" bright stainless steel bottom plate. Available version with wooden base covered by 20mm natural polished Sahara Noir, Stardust Grey or Calacatta Vagli Oro marble and antique bronze, lead or patinated bronze painted glass top in predefined combinations.

## TECHNICAL INFORMATION ON THE MATERIALS

**MARBLE** | The marble is a natural material of sedimentary origin that can present particularities such as veins, slight surface irregularities, different colors and crystallizations. These peculiarities are to be attributed to the naturalness of the material and are not to be considered defects but typical characteristics of marble. Each product will be unique, exclusive and non-replicable.

**GLASS** | Exclusive finishes, resulting from the craftsmanship on the glass, may show streaks and chromatic differences. These characteristics should not be considered imperfections but distinctive evidence of the hand-made process that enhance the beauty and peculiarity of the unique piece.



## Cm

260 x 120 x 74  
280 x 120 x 74  
300 x 120 x 74  
360 x 120 x 74  
400 x 120 x 74  
460 x 120 x 74  
500 x 120 x 74

## Inches

102½" x 47¼" x 29¼"  
110¼" x 47¼" x 29¼"  
118¼" x 47¼" x 29¼"  
141¼" x 47¼" x 29¼"  
157½" x 47¼" x 29¼"  
181¼" x 47¼" x 29¼"  
197" x 47¼" x 29¼"

For technical drawing / p. 85.

Pricelist 2023 / p. 26  
Homescapes, sense of materials / p. 44  
Homescapes, gentle attitude / pp. 81, 83

## PIANO/TOP

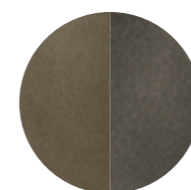

**Cristallo verniciato  
Bronzo antico / Piombo**  
Antique bronze / Lead  
painted glass



**Cristallo verniciato  
bronzo patinato**  
Patinated bronze  
painted glass

## BASE/BASE



**Marmo lucido naturale  
Sahara Noir**  
Natural polished  
Sahara Noir marble

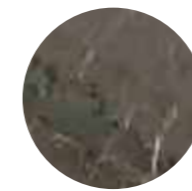

**Marmo lucido naturale  
Stardust Grey**  
Natural polished  
Stardust Grey marble



**Marmo lucido naturale  
Calacatta Vagli Oro**  
Natural polished  
Calacatta Vagli Oro marble

## PIATTO A TERRA / BOTTOM PLATE



**Acciaio inox lucido  
"supermirror"**  
"Supermirror" bright  
stainless steel

## DETTAGLI/DETAILS



**Ottone satinato**  
Satin brass

▲ PLATIUM SYSTEM  
Piano decorato nella finitura esclusiva bronzo antico / Dettaglio in ottone satinato  
Decorated by hand with an exclusive finish antique bronze top / Satin brass top detail

# Platium W

Oscar e Gabriele Buratti / 2017

Tavolo con piano in frassino spazzolato tinto nero con bisello da 50mm. Base in legno rivestito in marmo lucido naturale 20mm Sahara Noir o Stardust Grey e piatto a terra in acciaio inox lucido "supermirror".

Table with black stained brushed ash top with 50mm bevel. Wooden base covered with 20mm natural polished Sahara Noir or Grey Stardust marble and "supermirror" bright stainless steel bottom plate.

## NOTE TECNICHE SUI MATERIALI

**MARMO** | Il marmo è un materiale naturale di origine sedimentaria che può presentare particolarità come venature, lievi irregolarità superficiali, colorazioni differenti e cristallizzazioni. Queste peculiarità sono da attribuirsi alla naturalezza del materiale e non sono da considerarsi difetti ma caratteristiche tipiche del marmo. Ogni prodotto risulterà unico, esclusivo e non replicabile.

## TECHNICAL INFORMATION ON THE MATERIALS

**MARBLE** | The marble is a natural material of sedimentary origin that can present particularities such as veins, slight surface irregularities, different colors and crystallizations. These peculiarities are to be attributed to the naturalness of the material and are not to be considered defects but typical characteristics of marble. Each product will be unique, exclusive and non-replicable.



### Cm

260 x 120 x 75  
280 x 120 x 75  
300 x 120 x 75

### Inches

102½" x 47¼" x 29¾"  
110¾" x 47¼" x 29¾"  
118¼" x 47¼" x 29¾"

[For technical drawing / p. 86](#)

[Pricelist 2023 / p. 28](#)

## PIANO/TOP

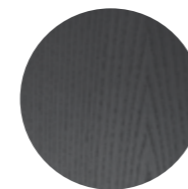

**Frassino spazzolato tinto nero**  
Black stained brushed ash

## BASE/BASE



**Marmo lucido naturale Sahara Noir**  
Natural polished Sahara Noir marble

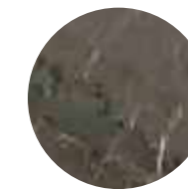

**Marmo lucido naturale Stardust Grey**  
Natural polished Stardust Grey marble

## PIATTO A TERRA / BOTTOM PLATE

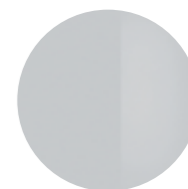

**Acciaio inox lucido "supermirror"**  
"Supermirror" bright stainless steel

▲ **PLATIUM W**  
Piano in frassino tinto nero / Base in marmo Stardust grigio  
Black stained brushed ash top / Grey Stardust marble base



# Prism

david/nicolas / 2019

Tavolo in legno con moderno ed elegante intarsio di palissandro India e alluminio naturale. Caratteristica del piano, è l'importante curvatura inferiore.

Wooden table with modern and elegant marquetry of India rosewood and aluminium. The top features a distinctive bottom curve.

## NOTE TECNICHE SUI MATERIALI

**INTARSIO** | L'intarsio è una tecnica di lavorazione artigianale utilizzata per ottenere un particolare disegno e si realizza accostando elementi di materiali differenti (come legno e alluminio) oppure dello stesso materiale. Questa lavorazione rende il prodotto unico ed esclusivo. Le eventuali variazioni cromatiche e di venatura del legno sono da considerarsi caratteristiche del materiale stesso e non possono essere controllate.

## TECHNICAL INFORMATION ON THE MATERIALS

**INLAY** | Inlay is an artisanal technique used to obtain a particular design and is made by combining elements of different materials (such as wood and aluminium) or of the same material. This process makes the product unique and exclusive. Any colour and grain variations of the wood are to be considered as characteristics of the material itself and cannot be controlled.



**Cm**  
260 x 125 x 74  
280 x 125 x 74

**Inches**  
102½" x 49¼" x 29¼"  
110¼" x 49¼" x 29¼"

[For technical drawing / p. 86](#)

[Pricelist 2023 / p. 29](#)  
[Homescapes, sense of materials / p. 60](#)

## STRUTTURA/STRUCTURE

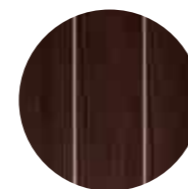

**Legno palissandro India  
e alluminio naturale**  
India rosewood  
and aluminium



▲ **RE-VERRE TABLE**  
 Vetro riciclato beige "sable"  
 Recycled glass "sable" beige

# Re-verre Table

Federica Biasi / 2024

Tavolo monomaterico in vetro riciclato nei colori beige "sable" o grigio "roche".

Trattandosi di una lavorazione artigianale e manuale le misure sono indicative e la superficie potrebbe essere porosa e non essere completamente planare.

Table in recycled glass in "sable" beige or "roche" grey colours.

Since this is an artisanal and manual process, the measurements are indicative and the surface may be porous and not completely flat.



**Cm**  
 Ø180 x 73  
 Ø200 x 73

**Inches**  
 Ø71" x 28¾"  
 Ø78¾" x 28¾"

[For technical drawing / p. 86](#)

[Homescapes, sense of materials / p. 60](#)

## STRUTTURA/STRUCTURE



Vetro riciclato  
 beige "sable"  
 Recycled glass  
 "sable" beige

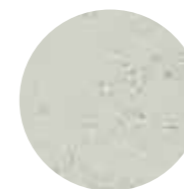

Vetro riciclato  
 grigio "roche"  
 Recycled glass  
 "roche" grey



▲ SELCE-T  
 Polvere di pietre naturali "Bruciato"  
 Natural stone powder "Bruciato"

# Selce-T

Studiopepe / 2024

Tavolo realizzato applicando polvere di pietre naturali attraverso una tecnica di spatolatura manuale.  
 Disponibile nei colori "bruciato" e "crema".

Trattandosi di una miscela di pietre naturali polverizzate, non si garantisce un'uniformità nelle tonalità cromatiche.

Table made by applying natural stone powder through a manual spatula technique.  
 Available in "bruciato" and "crema" colors.

Since it is a mixture of pulverized natural stones, uniformity in the color shades is not guaranteed.



	Cm	Inches
○	Ø130 x 74 Ø150 x 74	Ø51¼" x 29¼" Ø59¼" x 29¼"
□	220 x 120 x 74 240 x 120 x 74 280 x 130 x 74 300 x 130 x 74	86¾" x 47¼" x 29¼" 94½" x 47¼" x 29¼" 110¼" x 51¼" x 29¼" 118¼" x 51¼" x 29¼"

[For technical drawing / p. 87](#)

[Pricelist 2023 / p. 29](#)  
[Homescapes, sense of materials / p. 60](#)

## STRUTTURA/STRUCTURE



Polvere di pietre naturali  
 "Crema"  
 Natural stone powder  
 "Crema"

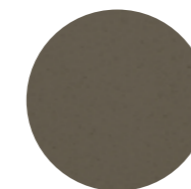

Polvere di pietre naturali  
 "Bruciato"  
 Natural stone powder  
 "Bruciato"



▲ SHIRO  
Piano intarsiato in legno "Ebano Capri"  
Inlaid wooden top in the finish "Ebano Capri"

# Shiro

Oscar e Gabriele Buratti / 2021

Tavolo con piano intarsiato in legno nella finitura "Ebano Capri". Disponibile anche con piano in marmo lucido naturale Calacatta Vagli Oro, Bianco Carrara Gioia o Verde Alpi. Basi ovalizzate rivestite in massello fresato di legno nella finitura "Ebano Capri" e dettagli in metallo cromato nero.

Table with inlaid wooden top in the finish "Ebano Capri". Also available with natural polished Calacatta Vagli Oro, Bianco Carrara Gioia or Verde Alpi marble. Ovalized bases covered by solid milled wood in the finish "Ebano Capri" and black chromed metal details.

## NOTE TECNICHE SUI MATERIALI

**MARMO** | Il marmo è un materiale naturale di origine sedimentaria che può presentare particolarità come venature, lievi irregolarità superficiali, colorazioni differenti e cristallizzazioni. Queste peculiarità sono da attribuirsi alla naturalezza del materiale e non sono da considerarsi difetti ma caratteristiche tipiche del marmo. Ogni prodotto risulterà unico, esclusivo e non replicabile. I nostri marmi vengono trattati con un prodotto idrorepellente che permette una maggiore protezione della superficie stessa, aumentando l'impermeabilità. Questo trattamento non esclude la vulnerabilità del marmo alle sostanze acide.

**INTARSIO** | L'intarsio è una tecnica di lavorazione artigianale utilizzata per ottenere un particolare disegno e si realizza accostando elementi di materiali differenti (come legno e alluminio) oppure dello stesso materiale. Questa lavorazione rende il prodotto unico ed esclusivo. Le eventuali variazioni cromatiche e di venatura del legno sono da considerarsi caratteristiche del materiale stesso e non possono essere controllate.

## TECHNICAL INFORMATION ON THE MATERIALS

**MARBLE** | The marble is a natural material of sedimentary origin that can present particularities such as veins, slight surface irregularities, different colors and crystallizations. These peculiarities are to be attributed to the naturalness of the material and are not to be considered defects but typical characteristics of marble. Each product will be unique, exclusive and non-replicable. Our marbles are treated with water-repellent products which affords greater protection to the surface of the marble, improving its impermeability. This treatment doesn't exclude the vulnerability of the marble to acid substances.

**INLAY** | Inlay is an artisanal technique used to obtain a particular design and is made by combining elements of different materials (such as wood and aluminium) or of the same material. This process makes the product unique and exclusive. Any colour and grain variations of the wood are to be considered as characteristics of the material itself and cannot be controlled.

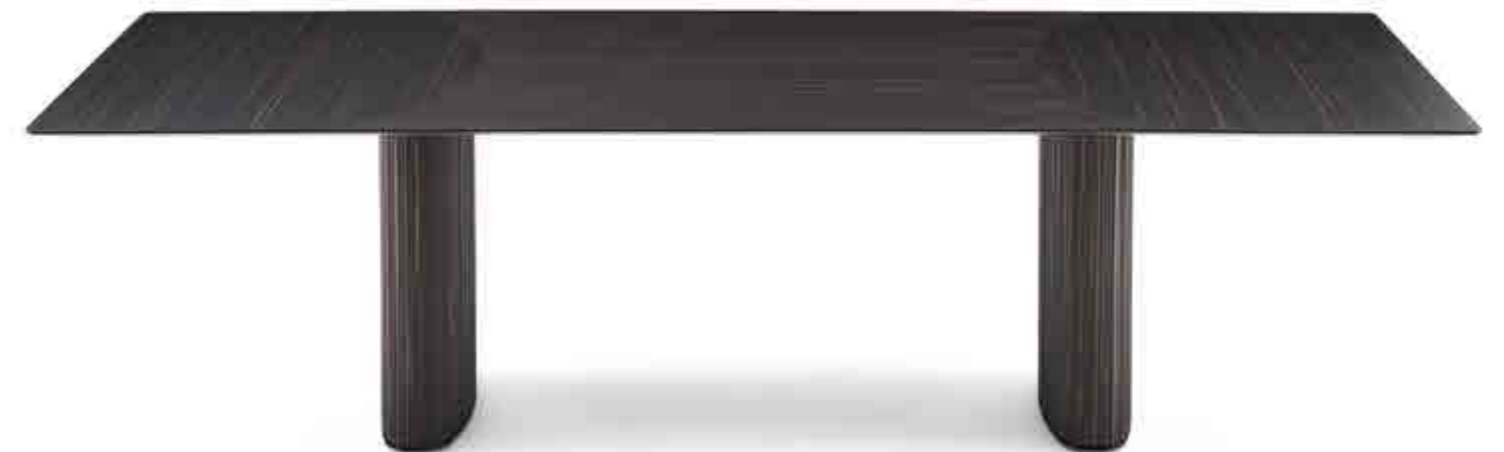

### Cm

240 x 120 x 74  
280 x 120 x 74

240 x 100 x 74  
280 x 110 x 74

### Inches

94½" x 47¼" x 29¼"  
110¼" x 47¼" x 29¼"

94½" x 39½" x 29¼"  
110¼" x 43½" x 29¼"

For technical drawing / p. 87

Pricelist 2023 / p. 30  
Homescapes, intimate portraits / p. 82

## PIANO/TOP



"Ebano Capri"  
"Ebano Capri"

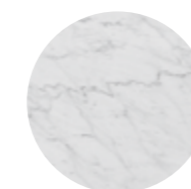

Marmo lucido naturale  
Bianco Carrara Gioia  
Natural polished  
Bianco Carrara Gioia marble



Marmo lucido naturale  
Calacatta Vagli Oro  
Natural polished  
Calacatta Vagli Oro marble



Marmo lucido naturale  
Verde Alpi  
Natural polished  
Verde Alpi marble

## BASE/BASE

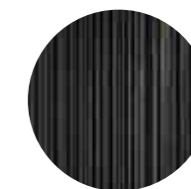

"Ebano Capri"  
"Ebano Capri"

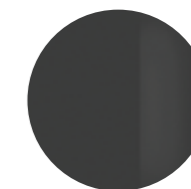

Metallo cromato nero  
Black chromed metal

## DETTAGLI/DETAILS



▲ **SIMPÒDIO**  
Base in cemento alleggerito avorio  
Lightened concrete in the colour ivory base

# Simpòdio

Pinuccio Borgonovo / 2022

Tavolo con piano in cristallo 12mm temperato, disponibile in extralight o "grigio Italia".  
Basi in cemento alleggerito color avorio o carbone. Parti metalliche in metallo laccato color "canna di fucile".

Table with 12mm tempered glass top, available in extralight or smoked "grigio Italia".  
Bases in lightened concrete in the colour ivory or charcoal. Metal parts lacquered in the "gunmetal" colour.



	<b>Cm</b>	<b>Inches</b>
○	Ø 120 x 74,5	Ø 47¼" x 29½"
	Ø 140 x 74,5	Ø 55¼" x 29½"
	Ø 160 x 74,5	Ø 63" x 29½"
	Ø 180 x 74,5	Ø 71" x 29½"
	Ø 200 x 74,5	Ø 78¾" x 29½"
□	260 x 120 x 74,5	102½" x 47¼" x 29½"
	260 x 140 x 74,5	102½" x 55¼" x 29½"
	280 x 140 x 74,5	110¼" x 55¼" x 29½"
	300 x 140 x 74,5	118¾" x 55¼" x 29½"
	320 x 140 x 74,5	126" x 55¼" x 29½"
◻	260 x 120 x 74,5	102½" x 47¼" x 29½"

For technical drawing / p. 87

Pricelist 2023 / p. 31  
Homescapes, gentle attitude / pp. 69, 70

## PIANO/TOP



Cristallo extralight  
Extralight glass

## BASE/BASE



Cristallo "grigio Italia"  
Smoked "grigio Italia" glass

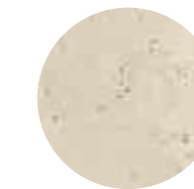

Cemento alleggerito avorio  
Lightened concrete in  
ivory colour



Cemento alleggerito carbone  
Lightened concrete in  
charcoal colour

## PARTI METALLICHE/ METAL PARTS

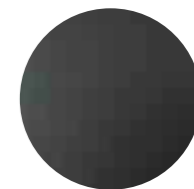

Legno laccato color  
"canna di fucile"  
Wooden lacquered  
"gunmetal" colour



▲ **SIMPÒDIO SYSTEM**  
Piano in cristallo extrlight/ Basi in cemento alleggerito avorio  
Extralight glass top/Lightened concrete in the colour ivory bases

# Simpòdio System

Pinuccio Borgonovo / 2022

Tavolo con piano in cristallo 12mm temperato, disponibile in extralight, "grigio Italia" o verniciato nella finitura esclusiva bronzo antico o piombo.  
Basi in cemento alleggerito color avorio o carbone. Parti metalliche in metallo laccato color "canna di fucile".

Table with 12mm tempered glass top, available in extralight, smoked "grigio Italia" or painted with the exclusive antique bronze and lead finish. Bases in lightened concrete in the colour ivory or charcoal. Metal parts lacquered in the "gunmetal" colour.



## Cm

260 x 140 x 74,5  
280 x 140 x 74,5  
300 x 140 x 74,5  
320 x 140 x 74,5  
350 x 150 x 74,5  
390 x 150 x 74,5  
430 x 150 x 74,5

## Inches

102½" x 55¼" x 29½"  
110¼" x 55¼" x 29½"  
118¼" x 55¼" x 29½"  
126" x 55¼" x 29½"  
138" x 59¼" x 29½"  
153¾" x 59¼" x 29½"  
169½" x 59¼" x 29½"

For technical drawing / p. 88

Pricelist 2023 / p.32  
Homescapes, gentle attitude / pp. 28, 35

## PIANO/TOP



Cristallo extralight  
Extralight glass



Cristallo "grigio Italia"  
Smoked "grigio Italia" glass

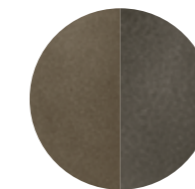

Bronzo antico / Piombo  
Antique bronze / Lead

## BASE/BASE

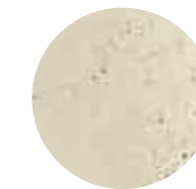

Cemento alleggerito avorio  
Lightened concrete in  
ivory colour



Cemento alleggerito  
carbone  
Lightened concrete  
in charcoal colour

## PARTI METALLICHE/ METAL PARTS



Legno laccato color  
"canna di fucile"  
Wooden lacquered  
"gunmetal" colour





▲ YOL  
Piano in cristallo extralight / Piano girevole in cristallo blu grigio satinato / Base in cristallo temperato retroverniciato blu grigio satinato  
Extralight glass top / Satin blue grey rotating plate / Blue grey satin tempered painted glass base

# Yol

Oscar e Gabriele Buratti / 2013

Tavolo con piano in cristallo extralight 15mm, retroverniciato solo nella parte centrale nei colori del campionario nella versione brillante. In appoggio, piano girevole in cristallo 10mm temperato retroverniciato nei colori del campionario nella versione brillante o satinata. Base in legno rivestita in cristallo 6mm temperato retroverniciato. Disponibile anche con piano completamente retroverniciato nei colori del campionario nella versione brillante o satinata. La retroverniciatura del piano nella parte centrale è realizzabile esclusivamente nella versione brillante.

! La retroverniciatura del piano nella parte centrale è realizzabile esclusivamente nella versione brillante.

Grazie al peso del cristallo il piano viene solo appoggiato sulla base e non necessita di fissaggio.

Table with 15mm extralight glass top, painted only in the middle part as per samples in the bright version. In the middle of the top rotating plate in 10mm tempered painted glass as per samples, in the bright or satin version. Wooden base covered by 6mm tempered painted glass. Also available with completely painted glass top as per samples in the bright or satin version. The painting of the glass top in the middle part can only be done in the bright version.

! The painting of the glass top in the middle part can only be done in the bright version.

Thanks to the weight of the glass, the top is only placed on the base and does not need to be fixed.



#### Cm

Ø 180 x 74  
Ø 200 x 74  
Ø 220 x 74  
Ø 240 x 74

#### Inches

Ø 71" x 29¼"  
Ø 78¾" x 29¼"  
Ø 86¾" x 29¼"  
Ø 94½" x 29¼"

For technical drawing / p. 88

Pricelist 2023 / p. 33

#### PIANO/TOP



Cristallo extralight  
Extralight glass

#### BASE/BASE



Sample box

Cristallo brillante/satinato  
nei colori del campionario  
Glass bright/satin version  
as per samples

#### PIANO E BASE/TOP AND BASE

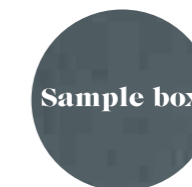

Sample box

Cristallo brillante/satinato  
nei colori del campionario  
Glass bright/satin version  
as per samples

#### PIANO GIREVOLE / ROTATING PLATE

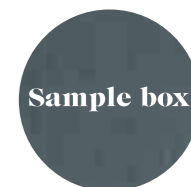

Sample box

Cristallo brillante/satinato  
nei colori del campionario  
Glass bright/satin version  
as per samples

# Yol Sect

Oscar e Gabriele Buratti / 2020

Tavolo con piano in legno o marmo diviso in quattro sezioni e girevole semi incassato in cristallo temperato 10mm con bisello da 35mm. Base in legno rivestita in cristallo 6mm temperato. Disponibile nelle combinazioni elencate.

! Il piano girevole è sporgente rispetto al piano di circa 5 millimetri.

## NOTE TECNICHE SUI MATERIALI

**CRISTALLO** | Le finiture esclusive risultano dalla lavorazione manuale realizzata sul cristallo possono presentare striature e differenze cromatiche. Queste caratteristiche non devono essere considerate difetti ma elementi distintivi del processo artigianale che esaltano la bellezza e la peculiarità del pezzo unico.

**MARMO** | Il marmo è un materiale naturale di origine sedimentaria che può presentare particolarità come venature, lievi irregolarità superficiali, colorazioni differenti e cristallizzazioni. Queste peculiarità sono da attribuirsi alla naturalezza del materiale e non sono da considerarsi difetti ma caratteristiche tipiche del marmo. Ogni prodotto risulterà unico, esclusivo e non replicabile. I nostri marmi vengono trattati con un prodotto idrorepellente che permette una maggiore protezione della superficie stessa, aumentando l'impermeabilità. Questo trattamento non esclude la vulnerabilità del marmo alle sostanze acide.

Table with wooden or marble top divided into four sections and 10mm semi-recessed rotating tempered glass plate with 35mm bevel. Wooden base covered by 6mm tempered glass. Available in the combinations as per our list.

! The rotating plate is protruding from the top by about 5 millimeters.

## TECHNICAL INFORMATION ON THE MATERIALS

**GLASS** | Exclusive finishes, resulting from the craftsmanship on the glass, may show streaks and chromatic differences. These characteristics should not be considered imperfections but distinctive evidence of the hand-made process that enhance the beauty and peculiarity of the unique piece.

**MARBLE** | The marble is a natural material of sedimentary origin that can present particularities such as veins, slight surface irregularities, different colors and crystallizations. These peculiarities are to be attributed to the naturalness of the material and are not to be considered defects but typical characteristics of marble. Each product will be unique, exclusive and non-replicable. Our marbles are treated with water-repellent products which affords greater protection to the surface of the marble, improving its impermeability. This treatment doesn't exclude the vulnerability of the marble to acid substances.

## COMBINAZIONI COMBINATIONS

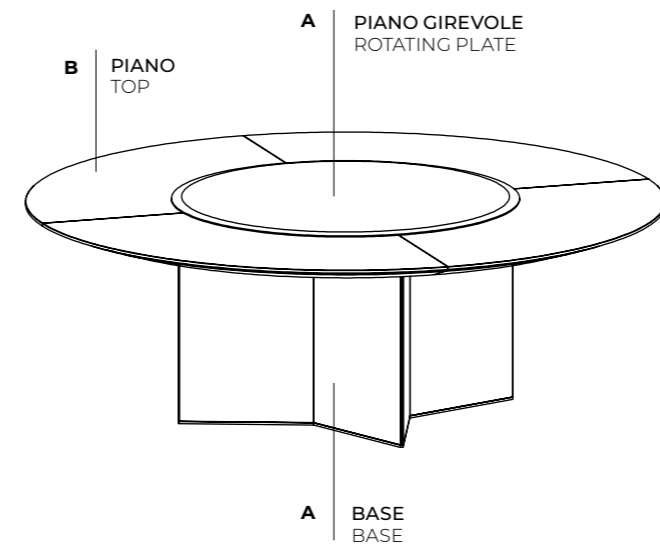

Le quattro sezioni del piano possono essere spostate per permettere la pulizia. The four sections of the top can be moved to allow cleaning.

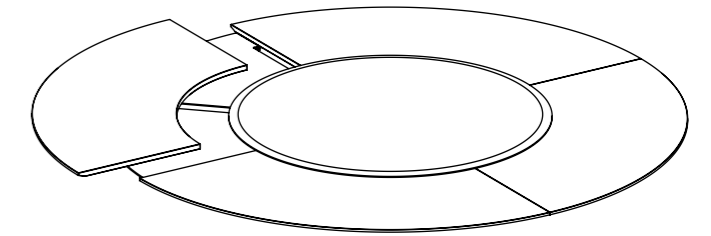

## Cm

Ø 180 x 74  
Ø 200 x 74  
Ø 220 x 74  
Ø 240 x 74

## Inches

Ø 71" x 29¼"  
Ø 78¾" x 29¼"  
Ø 86¾" x 29¼"  
Ø 94½" x 29¼"

For technical drawing / p.89

Pricelist 2023 / p. 34

### COMBINATION. A1

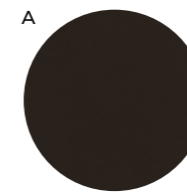

Cristallo retroverniciato  
nero satinato  
Satin black  
painted glass

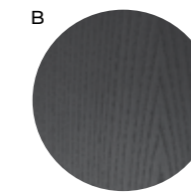

Frassino tinto  
nero a poro aperto  
Black open pore  
lacquered ash wood

### COMBINATION. B4

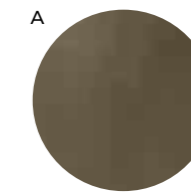

Cristallo verniciato  
bronzo antico  
Antique bronze  
painted glass

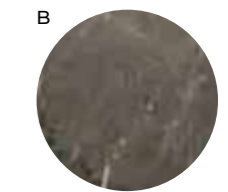

Marmo lucido naturale  
Stardust Grey  
Natural polished  
Stardust Grey

### COMBINATION. B1

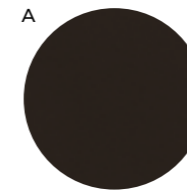

Cristallo retroverniciato  
nero satinato  
Satin black painted glass

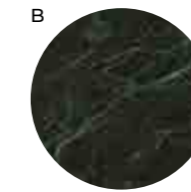

Marmo satinato Verde Alpi  
Verde Alpi satin marble

### COMBINATION. B5

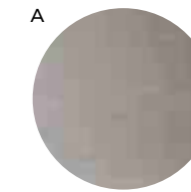

Cristallo verniciato  
"Cashmere" anthracite  
"Cashmere" anthracite  
painted glass

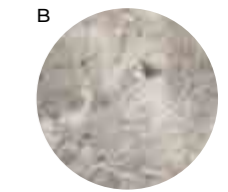

Marmo spazzolato  
Fior di Pesco  
Fior di Pesco  
brushed marble

### COMBINATION. B2

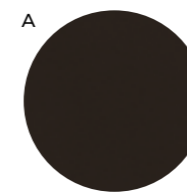

Cristallo retroverniciato  
nero satinato  
Satin black  
painted glass



Marmo levigato opaco  
Nero Marquinia  
Honed mat  
Nero Marquinia marble

### COMBINATION. B6

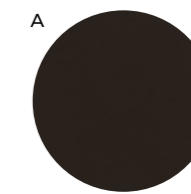

Cristallo verniciato  
piombo  
Lead painted glass

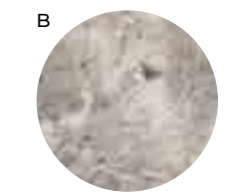

Marmo spazzolato  
Fior di Pesco  
Fior di Pesco  
brushed marble

### COMBINATION. B3

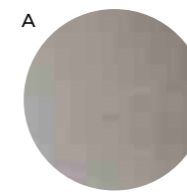

Cristallo verniciato  
"Cashmere" anthracite  
"Cashmere" anthracite  
painted glass

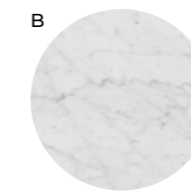

Marmo lucido naturale  
Bianco Carrara Gioia  
Natural polished  
Bianco Carrara Gioia marble

### COMBINATION. C1

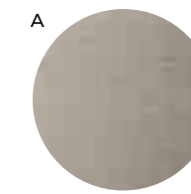

Cristallo verniciato  
"Cashmere" gold grey  
"Cashmere" gold grey  
painted glass



Marmo lucido naturale  
Calacatta Vagli Oro  
Natural polished Calacatta  
Vagli Oro marble



COMBINATION. A1



COMBINATION. B1



COMBINATION. B2



COMBINATION. B3



COMBINATION. B4



COMBINATION. B5



COMBINATION. B6



COMBINATION. C1

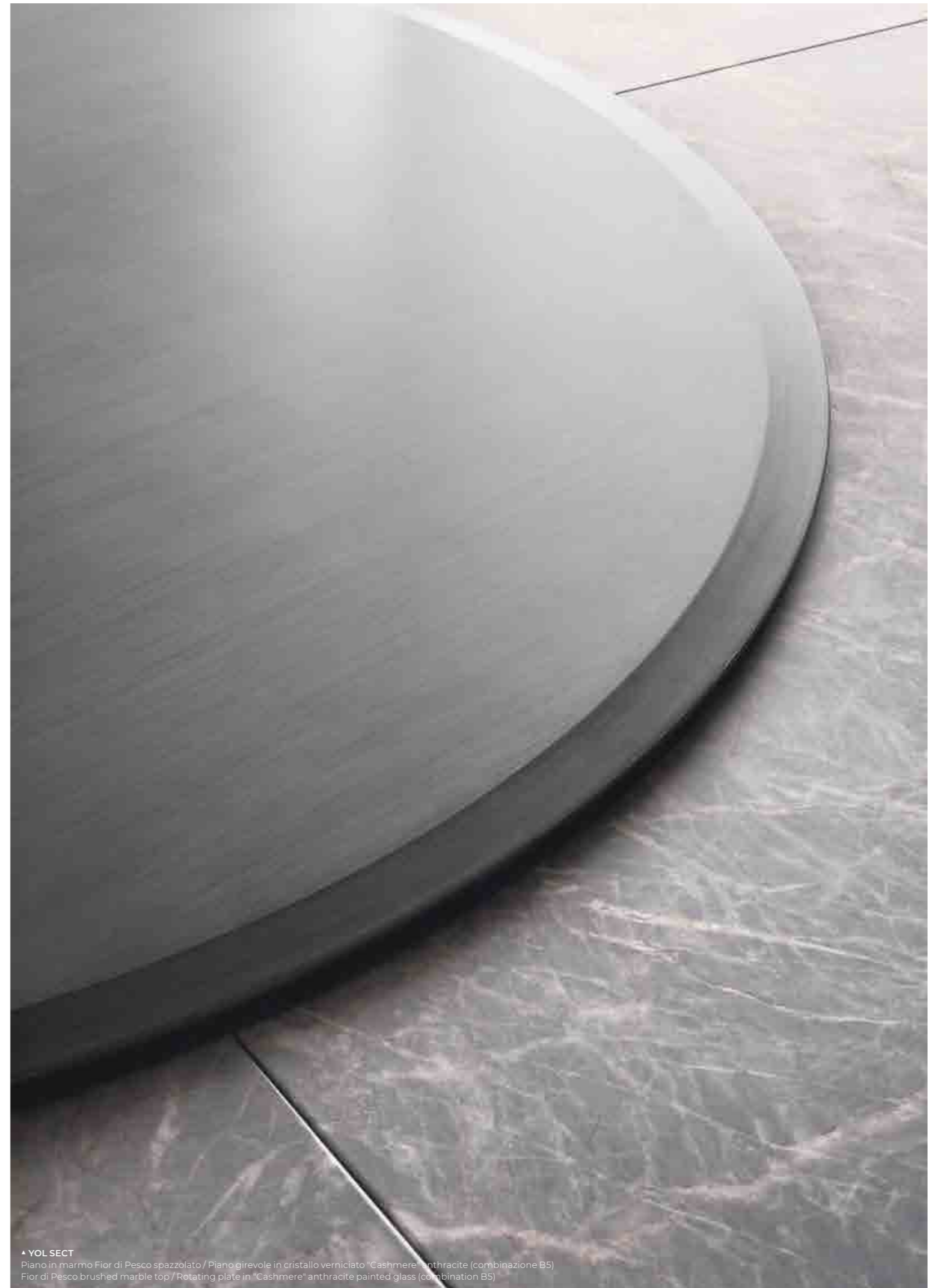

▲ YOL SECT  
Piano in marmo Fior di Pesco spazzolato / Piano girevole in cristallo verniciato "Cashmere" antracite (combinazione B5)  
Fior di Pesco brushed marble top / Rotating plate in "Cashmere" anthracite painted glass (combinazione B5)



▲ ZEN

Piano in frassino spazzolato tinto nero a poro aperto / Piano in cristallo decorato a mano Craquelé  
Black open pore brushed stained ash top / Hand-decorated Craquelé glass top

# Zen

Massimo Castagna / 2018

Tavolo con piano in frassino spazzolato tinto nero poro aperto. Disponibile anche con piano in cristallo temperato 8mm decorato a mano nella finitura Craquelé. Base in alluminio spazzolato a mano e anodizzato nero con dettagli ottonati lucidi.

Table with black open pore brushed stained ash top. Also available with tempered hand-decorated Craquelé 8mm glass top. Black hand brushed anodised aluminium base with bright brass plated details.

#### NOTE TECNICHE SUI MATERIALI

**CRISTALLO** | Le finiture esclusive risultato della lavorazione manuale realizzata sul cristallo possono presentare striature e differenze cromatiche. Queste caratteristiche non devono essere considerate difetti ma elementi distintivi del processo artigianale che esaltano la bellezza e la peculiarità del pezzo unico.

#### TECHNICAL INFORMATION ON THE MATERIALS

**GLASS** | Exclusive finishes, resulting from the craftsmanship on the glass, may show streaks and chromatic differences. These characteristics should not be considered imperfections but distinctive evidence of the hand-made process that enhance the beauty and peculiarity of the unique piece.



#### Cm

A Ø 100 x 65  
Ø 100 x 74

B-C-D 90 x 90 x 65  
90 x 90 x 74

#### Inches

Ø 39½" x 25¾"  
Ø 39½" x 29¼"

35½" x 35½" x 25¾"  
35½" x 35½" x 29¼"

For technical drawing / p.89

Pricelist 2023 / p. 36

#### PIANO/TOP

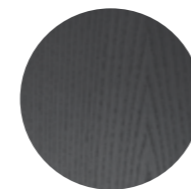

Frassino spazzolato tinto nero a poro aperto  
Black open pore brushed stained ash



Cristallo Craquelé  
Craquelé glass

#### BASE/BASE

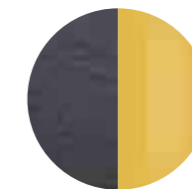

Alluminio spazzolato nero / Metallo ottonato lucido  
Black brushed aluminium / Bright brass metal

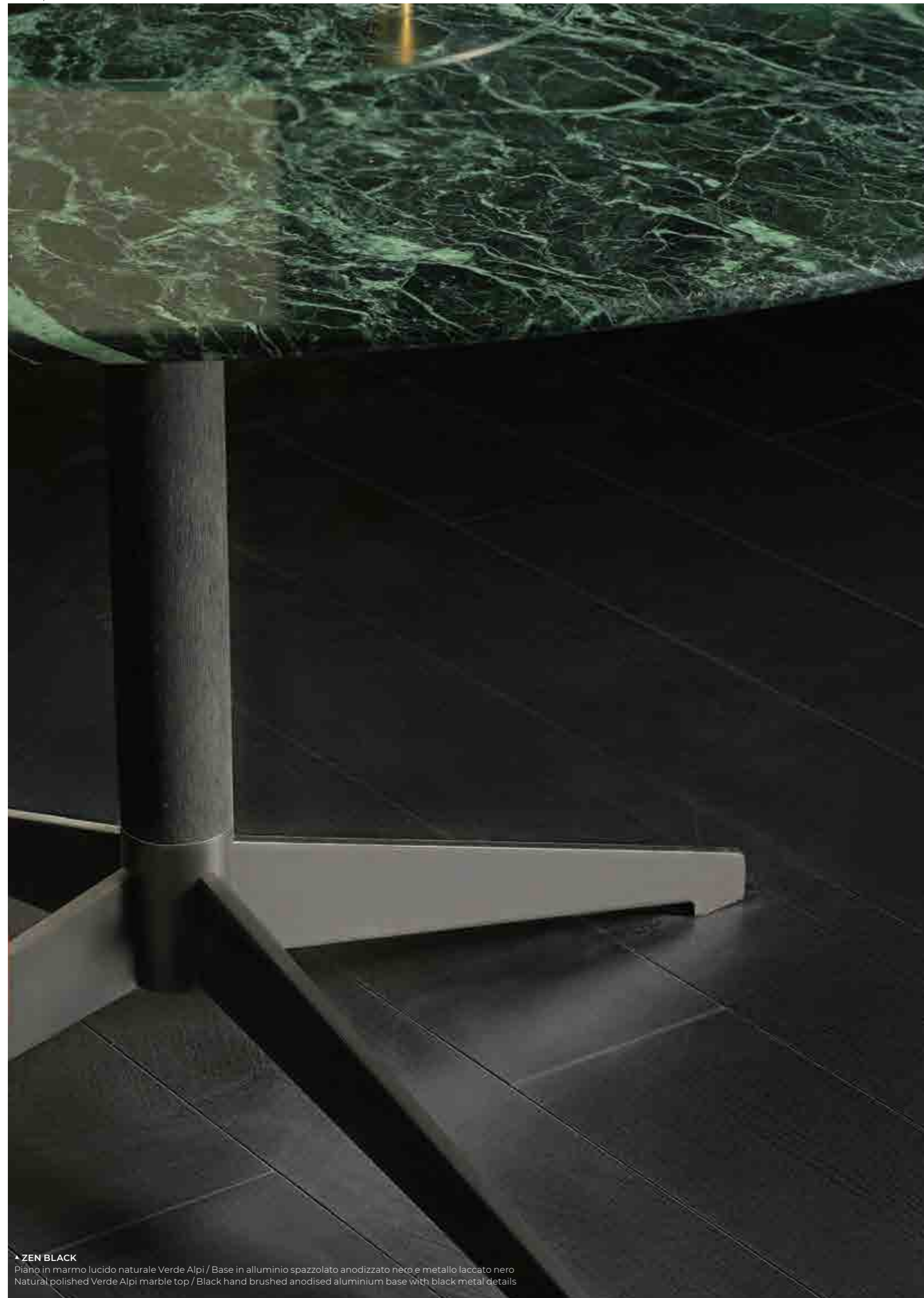

**ZEN BLACK**  
 Piano in marmo lucido naturale Verde Alpi / Base in alluminio spazzolato anodizzato nero e metallo laccato nero  
 Natural polished Verde Alpi marble top / Black hand brushed anodised aluminium base with black metal details

# Zen Black

Massimo Castagna / 2020

Tavolo con piano in frassino spazzolato tinto nero poro aperto. Disponibile anche in cristallo temperato 8mm decorato a mano nella finitura Craquelé oppure in marmo 20mm Verde Alpi lucido naturale, Nero Marquinia levigato opaco, Fior di Pesco spazzolato o Bianco Carrara Gioia lucido naturale. Base in alluminio spazzolato a mano e anodizzato nero con dettagli in metallo laccato nero.

Table with black brushed open pore stained ash top. Also available with 8mm tempered hand-decorated Craquelé glass top or in 20mm natural polished Verde Alpi marble, honed mat Nero Marquinia marble, brushed Fior di Pesco marble, natural polished Bianco Carrara Gioia marble. Black hand brushed anodised aluminium base with black metal details.

## NOTE TECNICHE SUI MATERIALI

**CRISTALLO** | Le finiture esclusive risultato della lavorazione manuale realizzata sul cristallo possono presentare striature e differenze cromatiche. Queste caratteristiche non devono essere considerate difetti ma elementi distintivi del processo artigianale che esaltano la bellezza e la peculiarità del pezzo unico.

**MARMO** | Il marmo è un materiale naturale di origine sedimentaria che può presentare particolarità come venature, lievi irregolarità superficiali, colorazioni differenti e cristallizzazioni. Queste peculiarità sono da attribuirsi alla naturalezza del materiale e non sono da considerarsi difetti ma caratteristiche tipiche del marmo. Ogni prodotto risulterà unico, esclusivo e non replicabile. I nostri marmi vengono trattati con un prodotto idrorepellente che permette una maggiore protezione della superficie stessa, aumentando l'impermeabilità. Questo trattamento non esclude la vulnerabilità del marmo alle sostanze acide.

## TECHNICAL INFORMATION ON THE MATERIALS

**GLASS** | Exclusive finishes, resulting from the craftsmanship on the glass, may show streaks and chromatic differences. These characteristics should not be considered imperfections but distinctive evidence of the hand-made process that enhance the beauty and peculiarity of the unique piece.

**MARBLE** | The marble is a natural material of sedimentary origin that can present particularities such as veins, slight surface irregularities, different colors and crystallizations. These peculiarities are to be attributed to the naturalness of the material and are not to be considered defects but typical characteristics of marble. Each product will be unique, exclusive and non-replicable. Our marbles are treated with water-repellent products which affords greater protection to the surface of the marble, improving its impermeability. This treatment doesn't exclude the vulnerability of the marble to acid substances.



## Cm

Ø 100 x 65  
 Ø 100 x 74  
 Ø 120 x 65  
 Ø 120 x 74

## Inches

Ø 39 1/2" x 25 3/4"  
 Ø 39 1/2" x 29 1/4"  
 Ø 47 1/4" x 25 3/4"  
 Ø 47 1/4" x 29 1/4"

For technical drawing / p.89

Pricelist 2023 / p.37

## PIANO/TOP

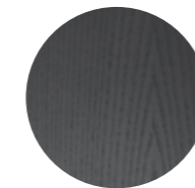

**Frassino spazzolato tinto nero a poro aperto**  
 Black open pore brushed stained ash



**Cristallo Craquelé**  
 Craquelé glass

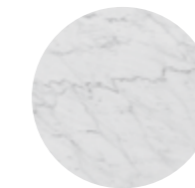

**Marmo lucido naturale Bianco Carrara Gioia**  
 Natural polished Bianco Carrara Gioia marble



**Marmo spazzolato Fior di Pesco**  
 Fior di Pesco brushed marble



**Marmo levigato opaco Nero Marquinia**  
 Honed mat Nero Marquinia marble



**Marmo lucido naturale Verde Alpi**  
 Natural polished Verde Alpi marble

## BASE/BASE

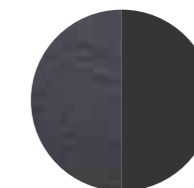

**Alluminio spazzolato e anodizzato nero/ Metallo laccato nero**  
 Hand brushed anodised aluminium / Black metal details



• **LAZY SUSAN**  
Piano girevole in cristallo extralight con parte centrale retroverniciata nero brillante  
Rotating plate in extralight glass with bright black painted central part

# Lazy Susan

Studio G&R / 1986

Piano girevole in cristallo extralight 10mm molato a bisello (10mm) con parte centrale retroverniciata nei colori del campionario nella versione brillante. Disponibile versione completamente retroverniciata nei colori del campionario nella versione brillante o satinata. Può essere appoggiato su qualsiasi piano.

! Nella versione con parte centrale retroverniciata la retroverniciatura è realizzabile esclusivamente nella versione brillante.

Rotating plate in 10mm extralight glass with bevelled edge (10mm). Painted glass central part as per sample in the bright version. Also available version completely painted as per samples in the bright or satin version. It can be placed on any top.

! In the painted glass central part version the painting in the middle part can only be done in the bright version.



Cm	Inches
Ø 70	Ø 27¾"
Ø 75	Ø 29¾"
Ø 80	Ø 31½"
Ø 85	Ø 33½"
Ø 90	Ø 35½"
Ø 95	Ø 37½"
Ø 100	Ø 39½"

[For technical drawing / p. 90](#)

[Pricelist 2023 / p. 192](#)

## PIANO GIREVOLE E PARTE CENTRALE ROTATING PLATE/CENTRAL PART



Cristallo extralight/Cristallo retroverniciato  
brillante nei colori del campionario  
Extralight glass/Bright  
painted glass as per samples

## PIANO GIREVOLE/ROTATING PLATE

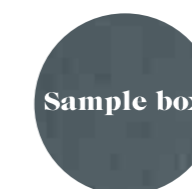

Cristallo retroverniciato brillante/satinato  
nei colori del campionario  
Bright/satin painted glass  
as per samples

# 01

**Tavoli / Tables**  
**TECHNICAL MODULE**





**Adam** | Studio G&R, 1971

Product information / p. 8

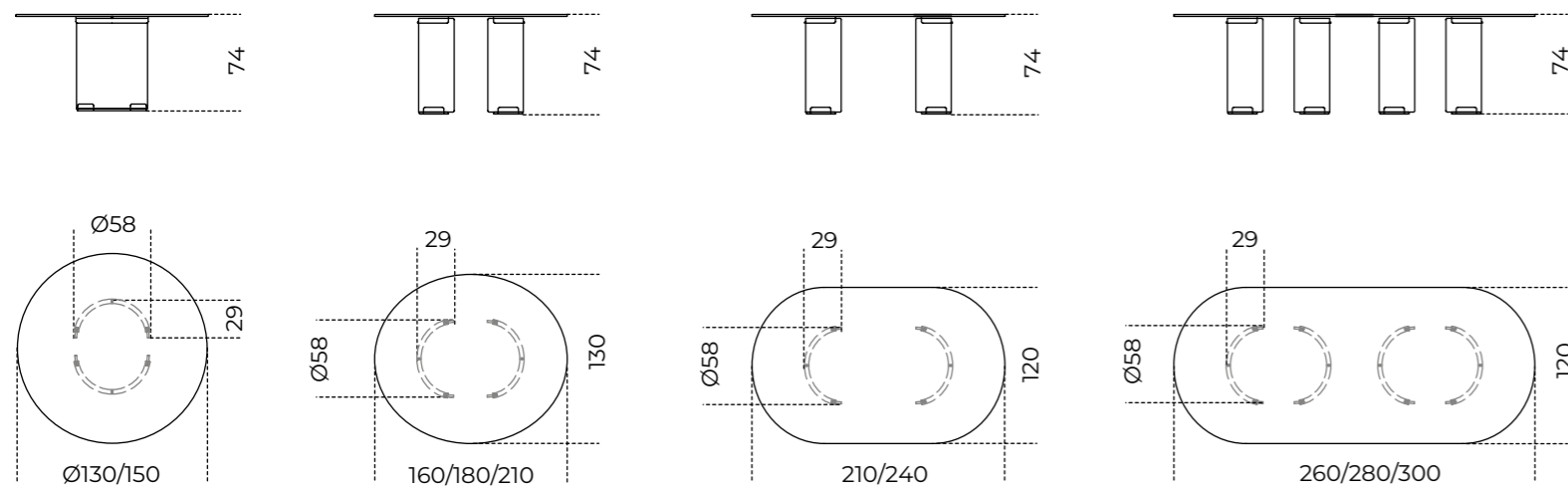

**Dolm Plus** | Oscar e Gabriele Buratti, 2019

Product information / p. 14

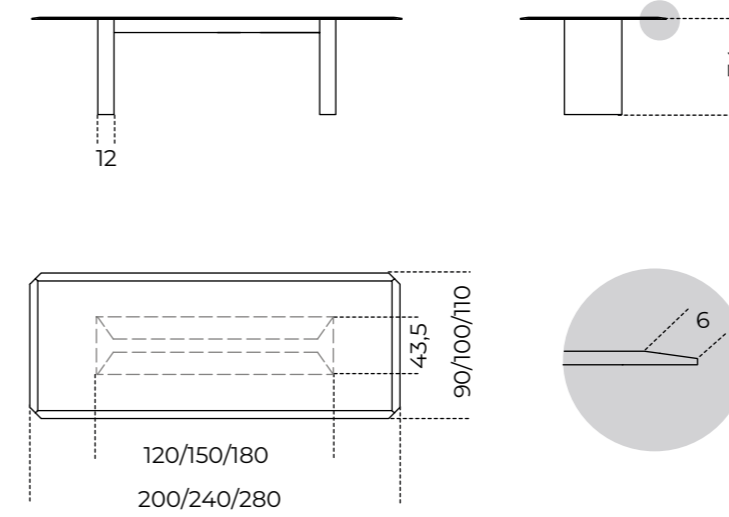

**Clemo-T** | Massimo Castagna, 2022

Product information / p. 10

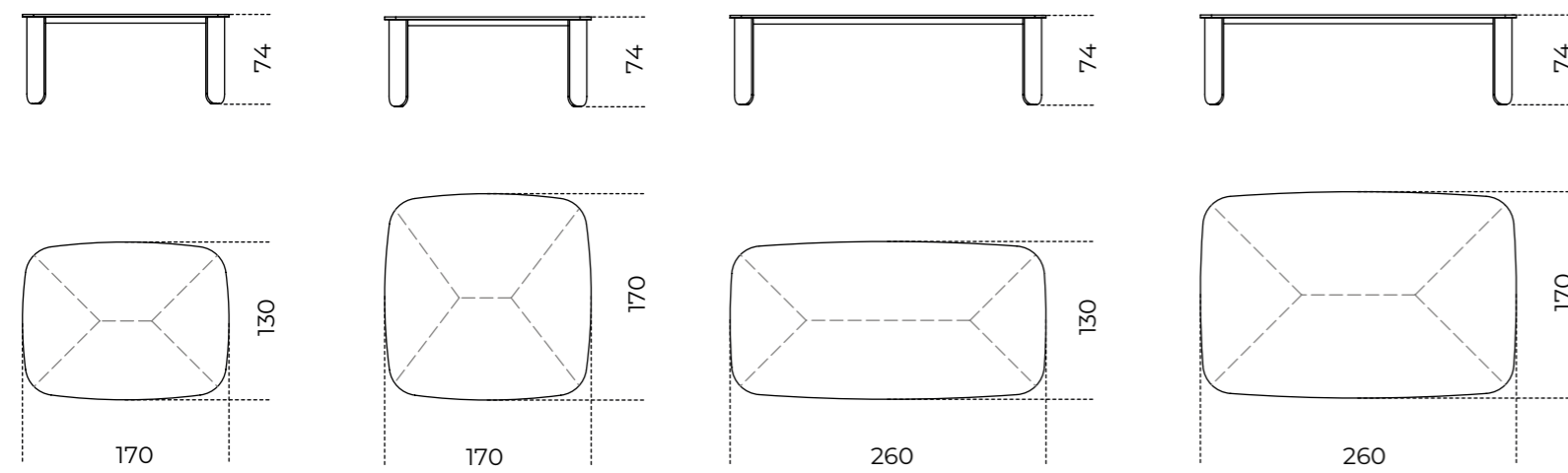

**Eros** | Pierangelo Gallotti, 1971

Product information / p. 16

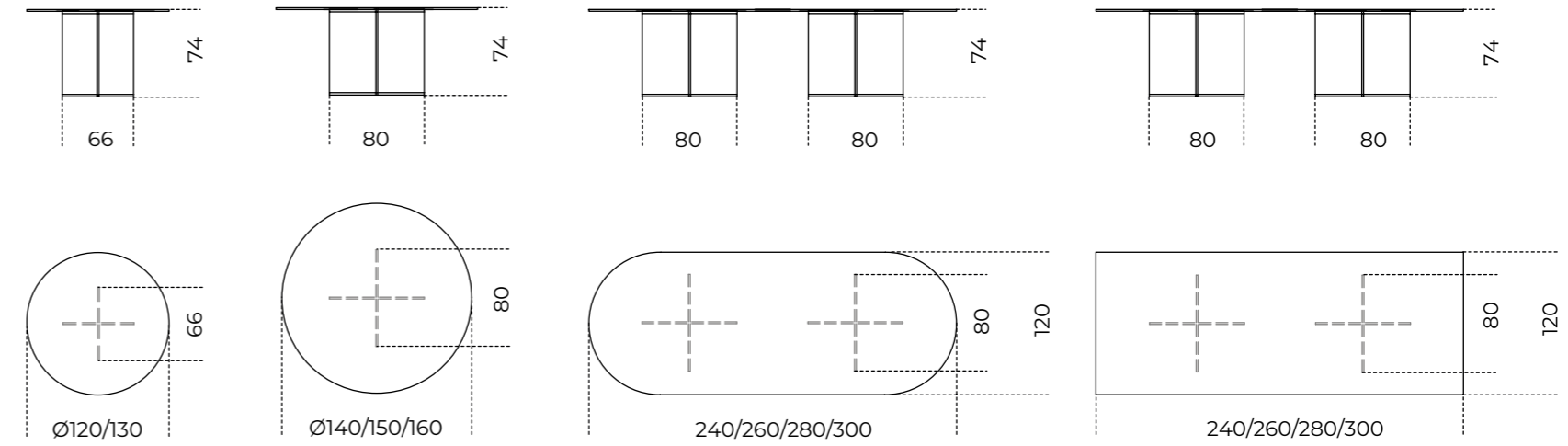

**Dolm** | Oscar e Gabriele Buratti, 2012

Product information / p. 12

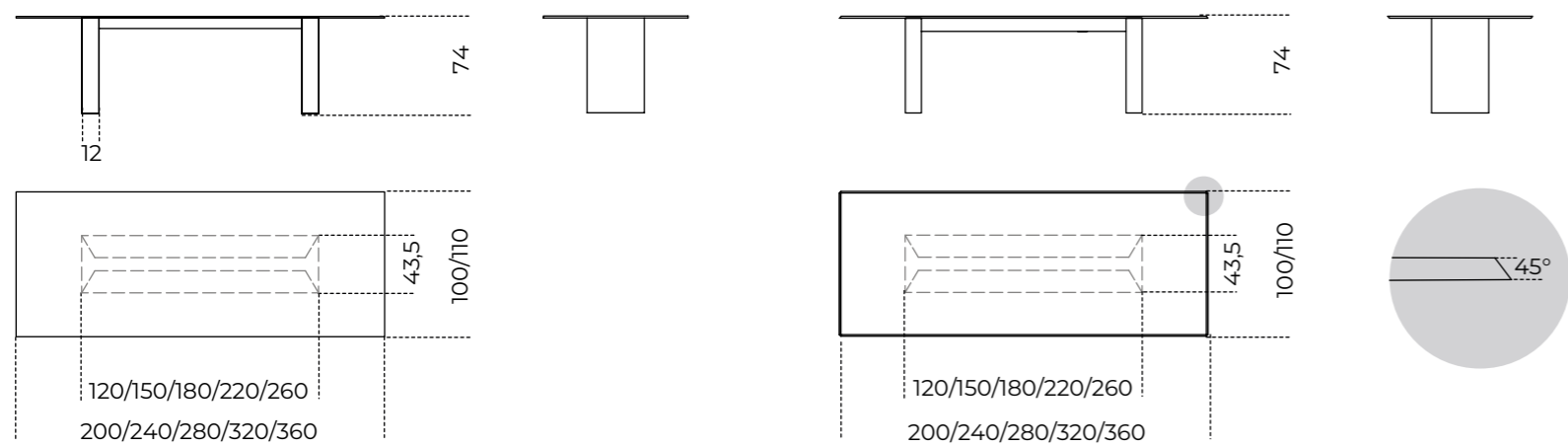

**Piano bisellato**  
Bevelled glass top

**Eyl** | Oscar e Gabriele Buratti, 2014

Product information / p. 18

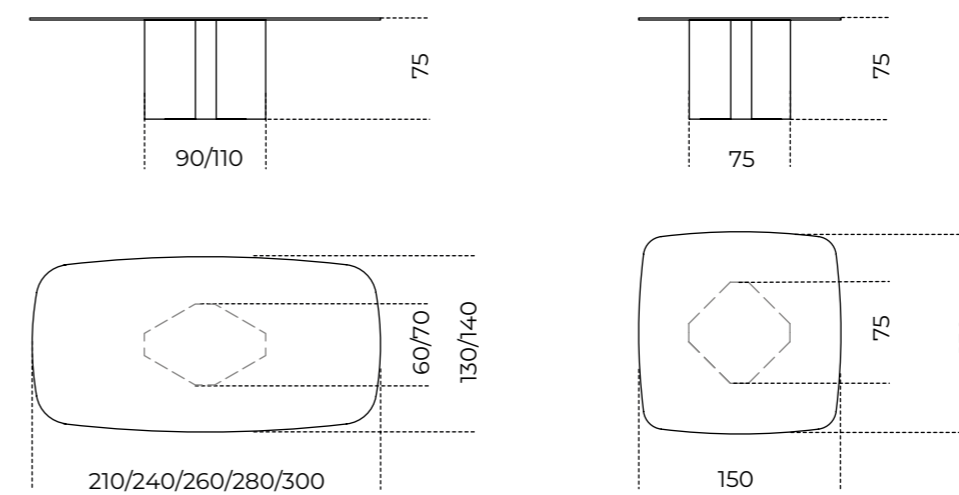

**Haumea-T** | Massimo Castagna, 2016

Product information / p.20

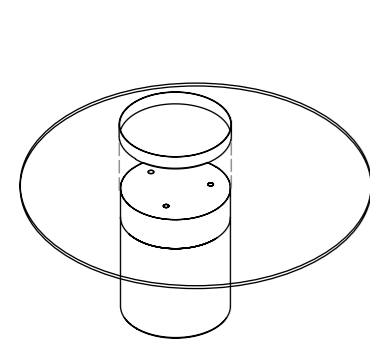
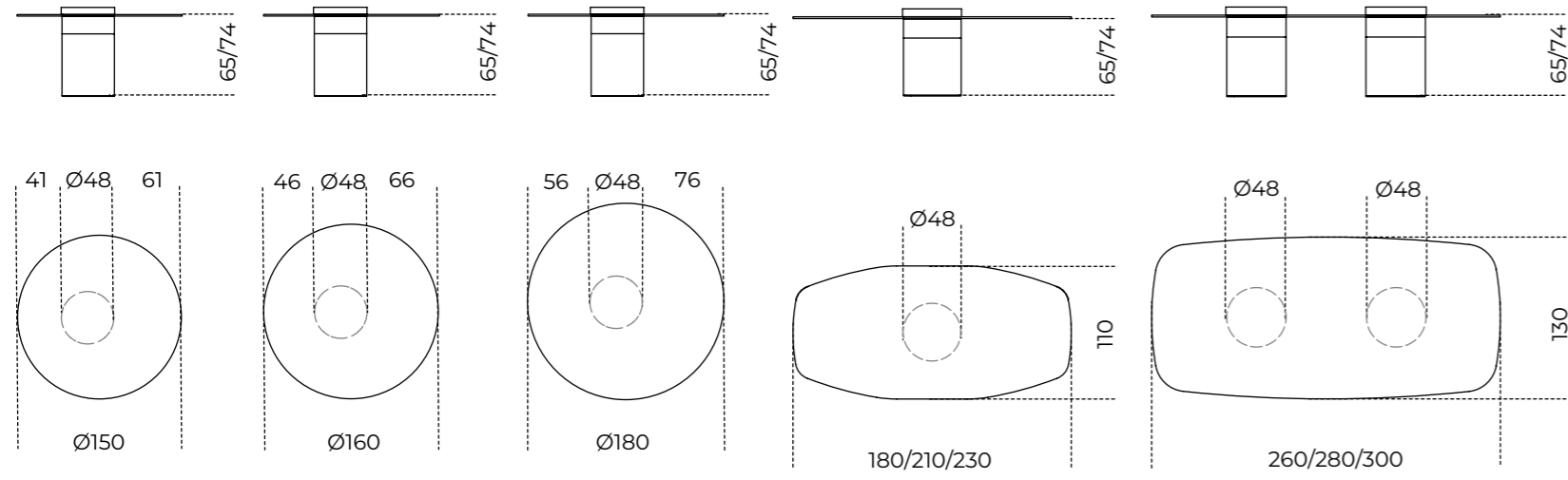

Nella versione con un basamento il piano è fissato alla base.  
In the version with one base the top is fixed.

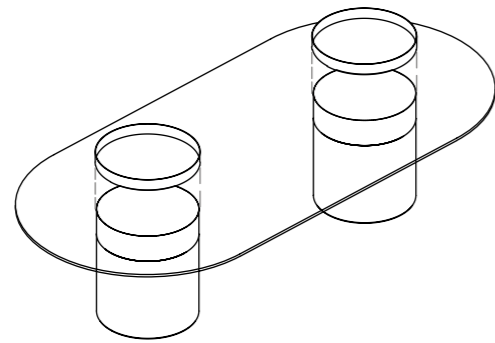

Nella versione con due basamenti il piano è solo in appoggio.  
In the version with two bases the top is just resting.

**Manto** | Pietro Russo, 2020

Product information / p.28

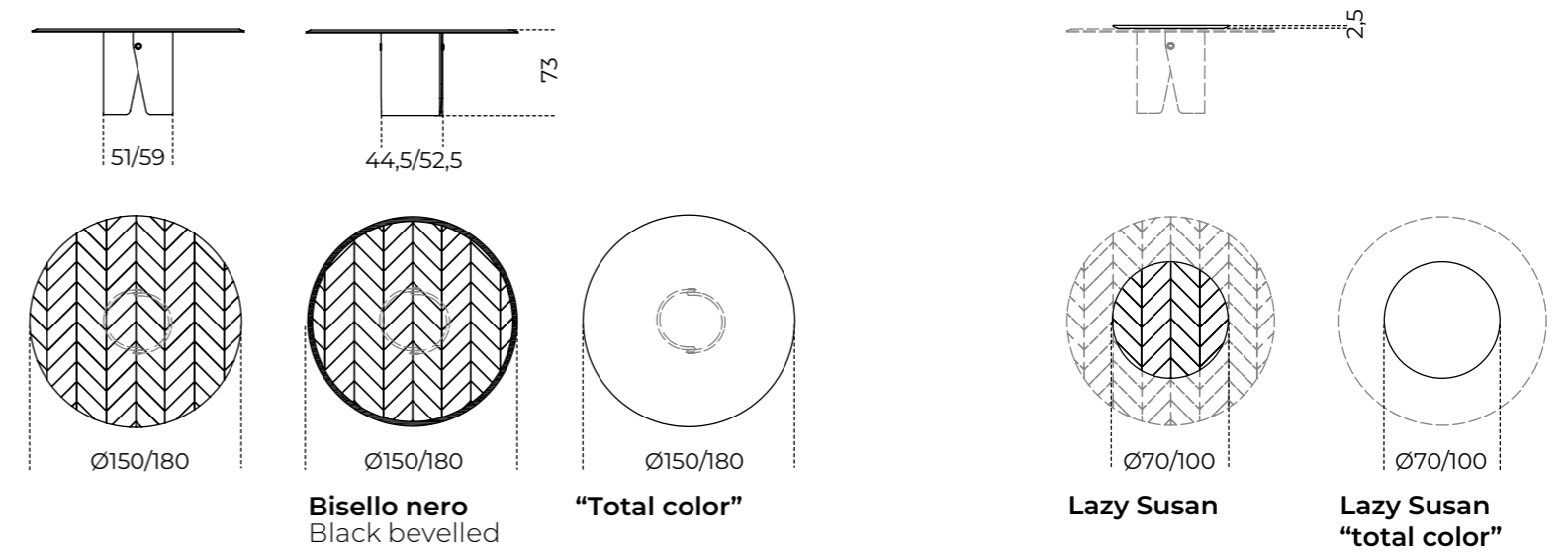

**Manto Oval** | Pietro Russo, 2020

Product information / p.30

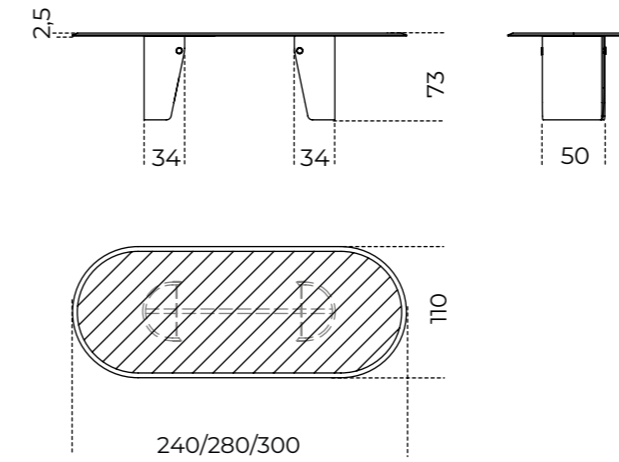

**Maat** | Pietro Russo, 2017

Product information / p.24

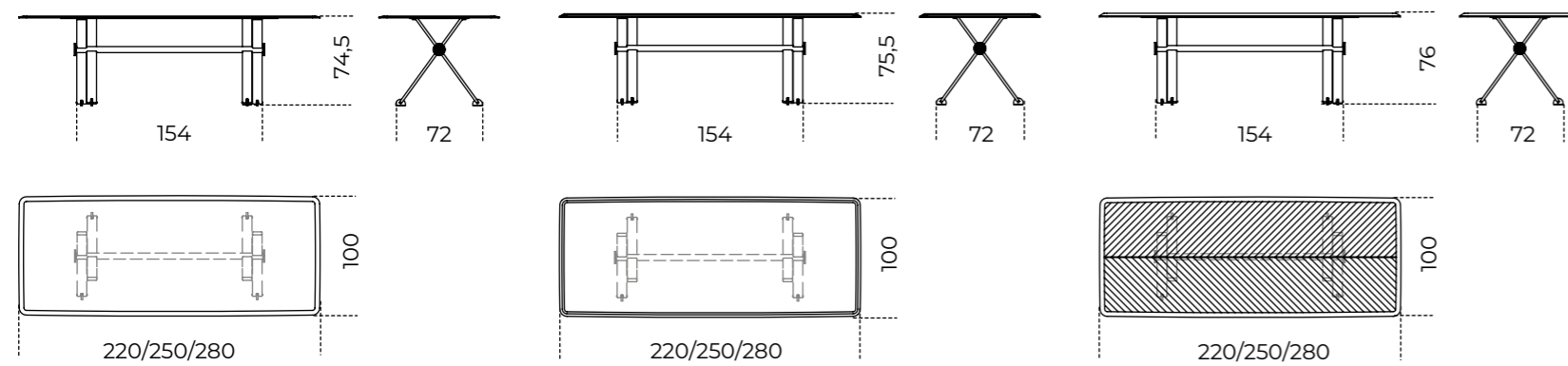

**Piano in cristallo**  
Glass top

**Piano in marmo**  
Marble top

**Piano in legno intarsiato**  
Inlaid wooden top

**Molecola** | Massimo Castagna, 2024

Product information / p.34

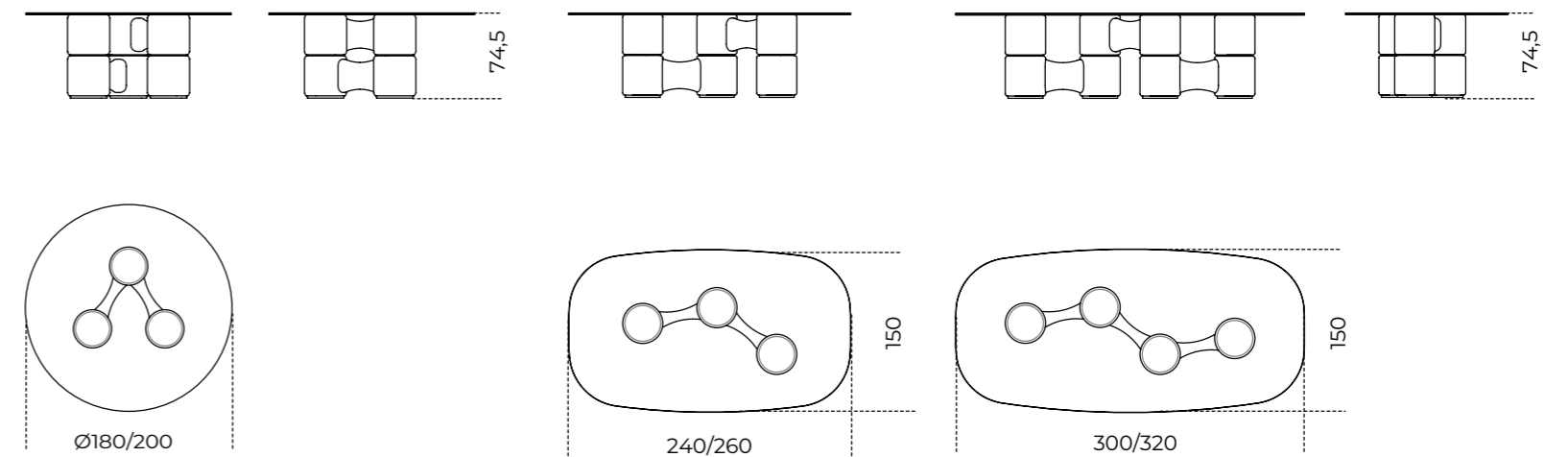

Oto | Oscar e Gabriele Buratti, 2015

Product information / p. 38

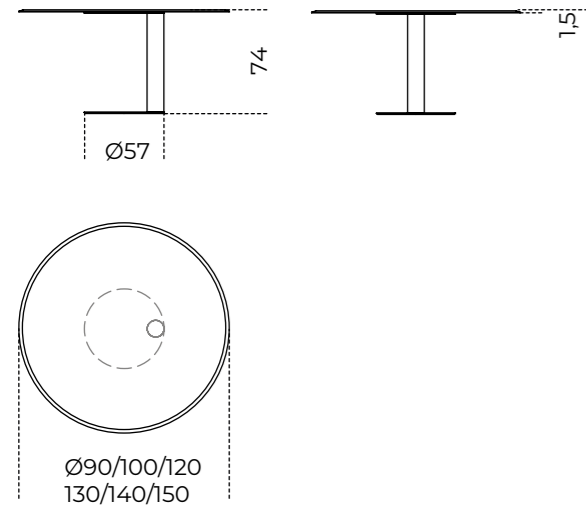

Platium | Oscar e Gabriele Buratti, 2016

Product information / p. 44

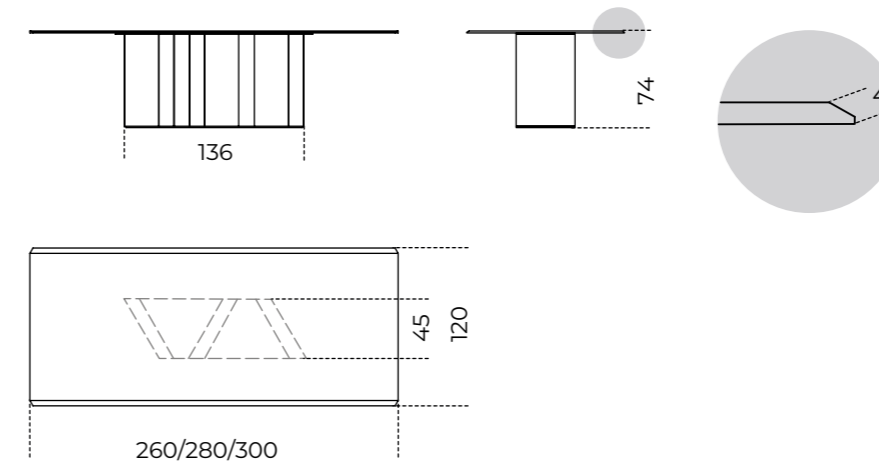

Oto Big | Oscar e Gabriele Buratti, 2018

Product information / p. 40

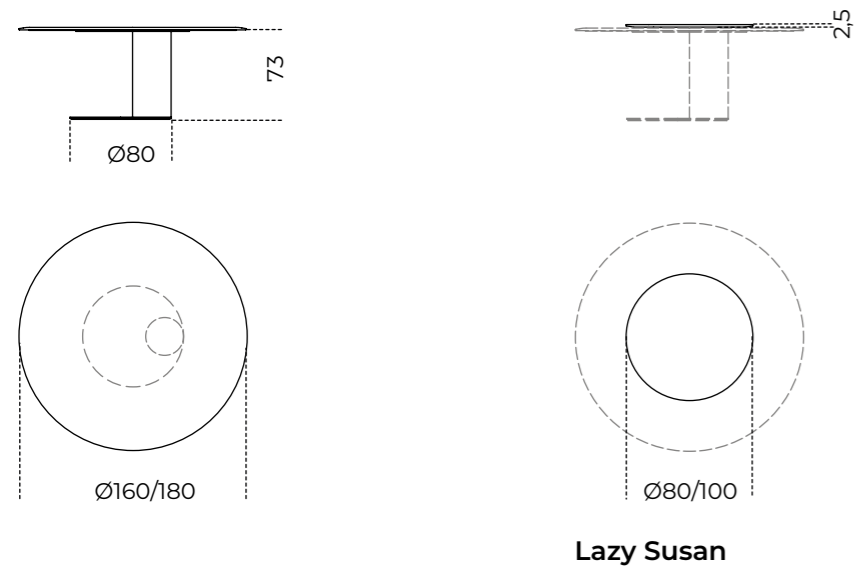

Platium Round | Oscar e Gabriele Buratti, 2018

Product information / p. 46

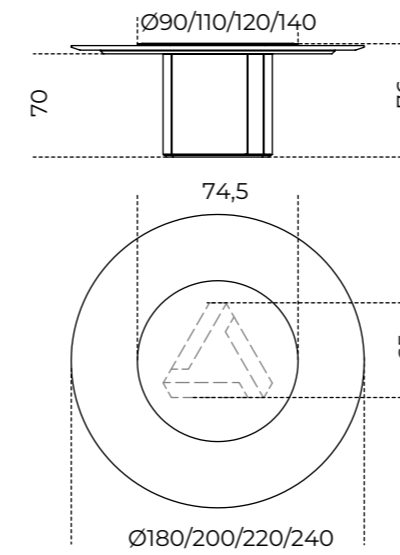

Oto Medium | Oscar e Gabriele Buratti, 2022

Product information / p. 42

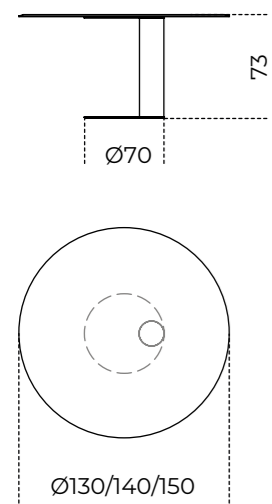

Platium System | Oscar e Gabriele Buratti, 2018

Product information / p. 48

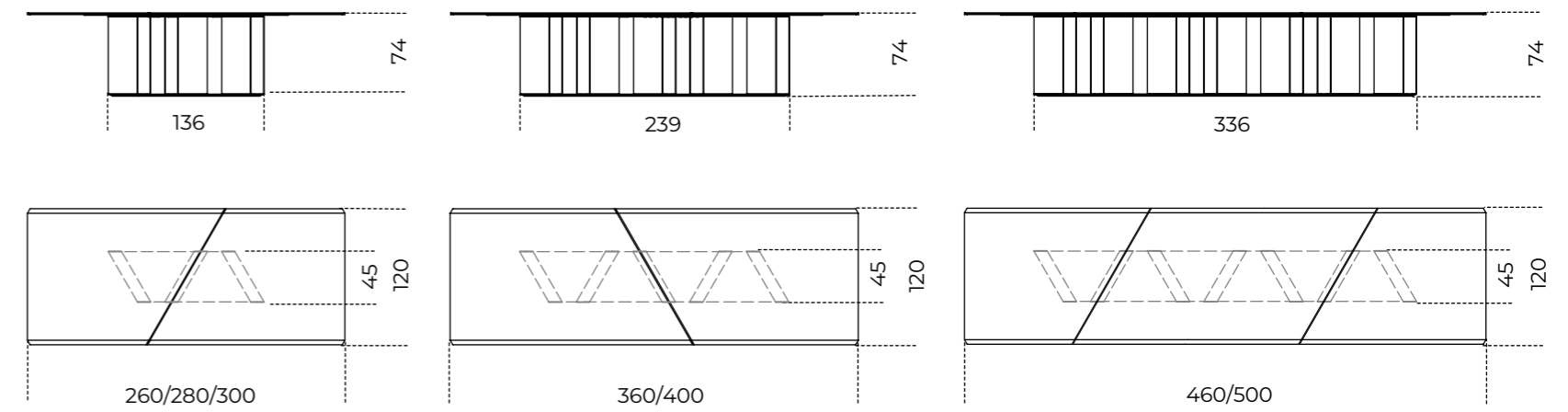

**Platium W** | Oscar e Gabriele Buratti, 2017

Product information / p. 50

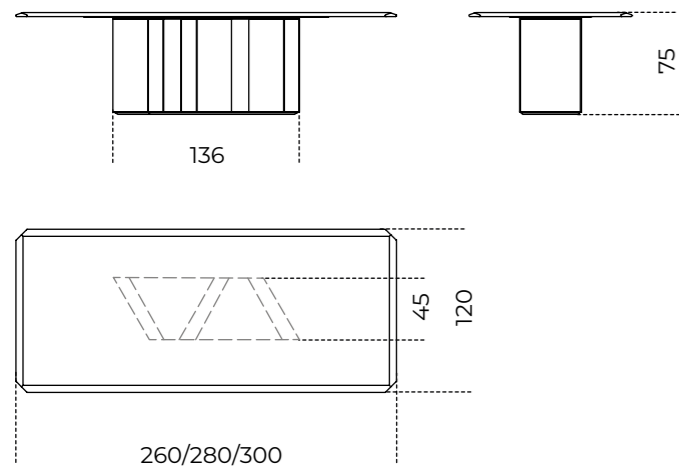

**Selce-T** | Studiopepe, 2024

Product information / p. 56

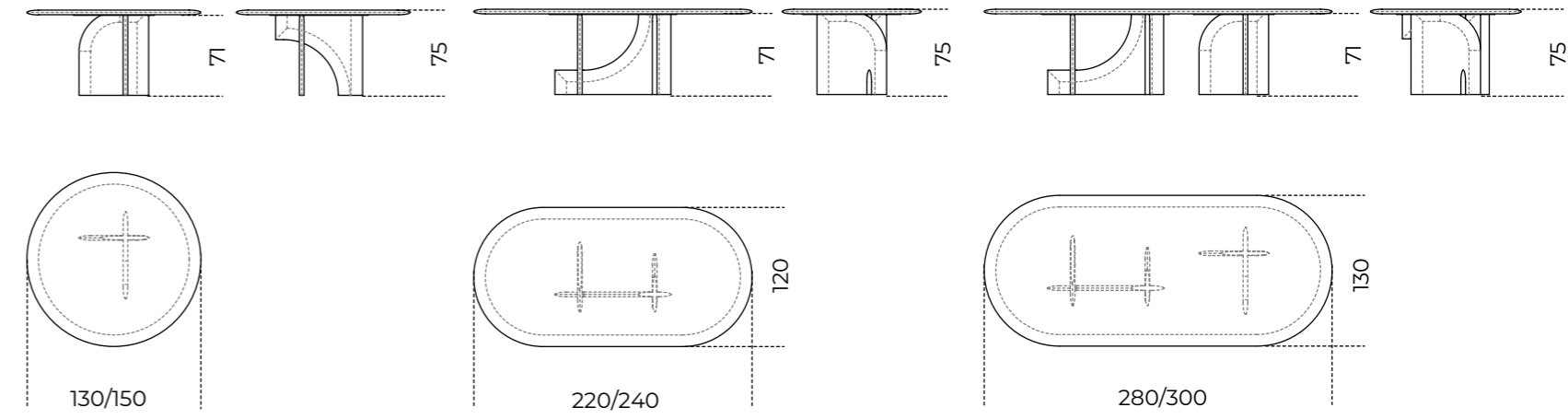

**Prism** | David/Nicolas, 2019

Product information / p. 52

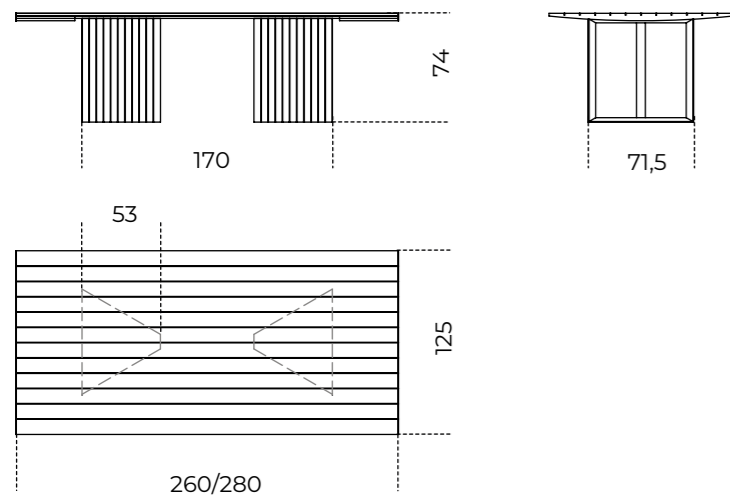

**Shiro** | Oscar e Gabriele Buratti, 2021

Product information / p. 58

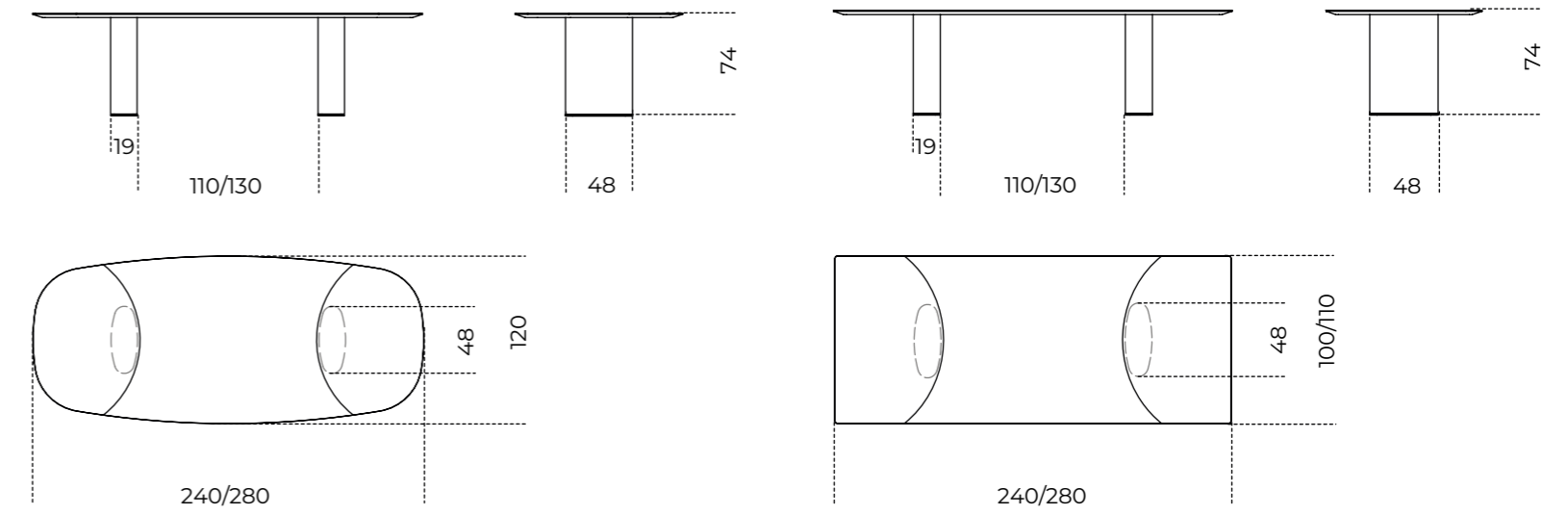

**Re-Verre Table** | Federica Biasi, 2024

Product information / p. 54

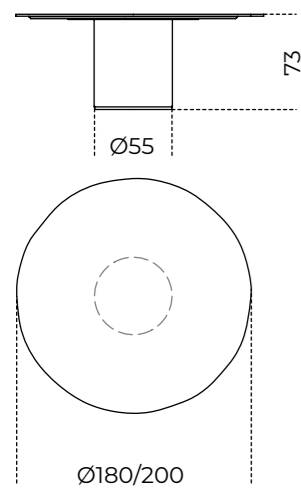

**Simpòdio** | Pinuccio Borgonovo, 2022

Product information / p. 60

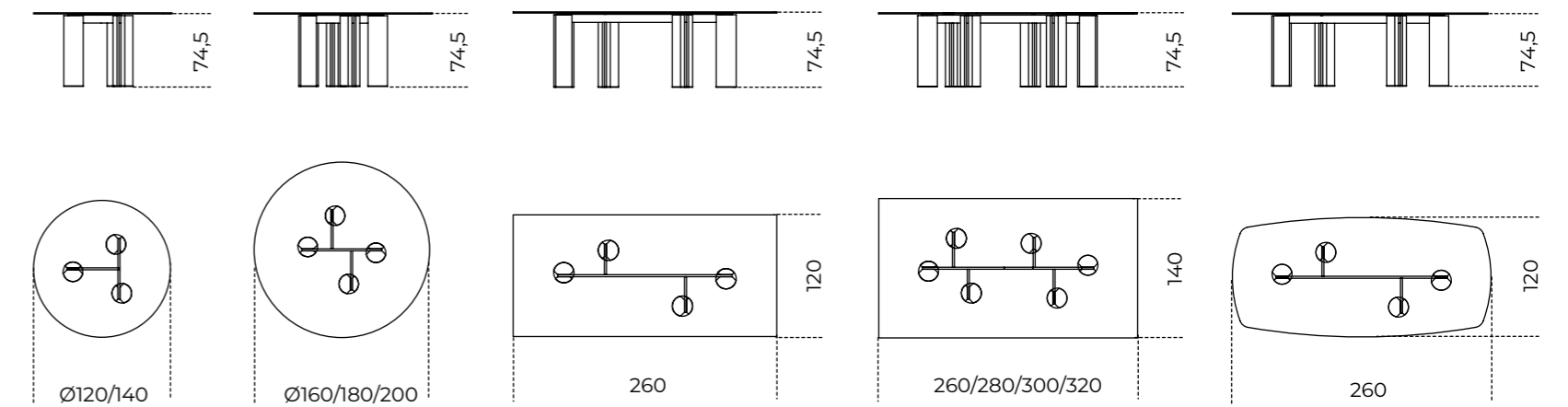

**Simpòdio System** | Pinuccio Borgonovo, 2022

Product information / p. 62

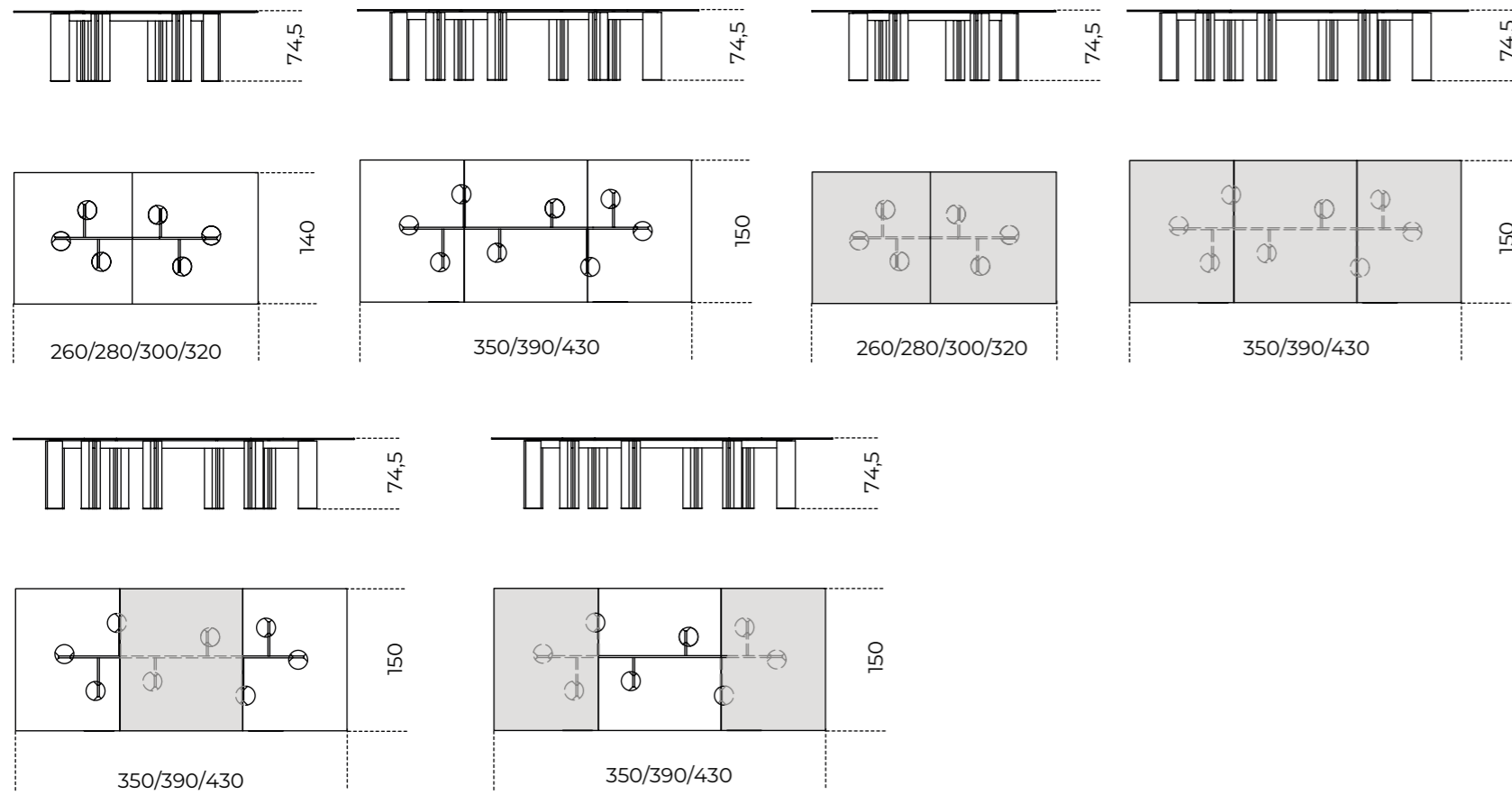

**Vol** | Oscar e Gabriele Buratti, 2013

Product information / p. 64

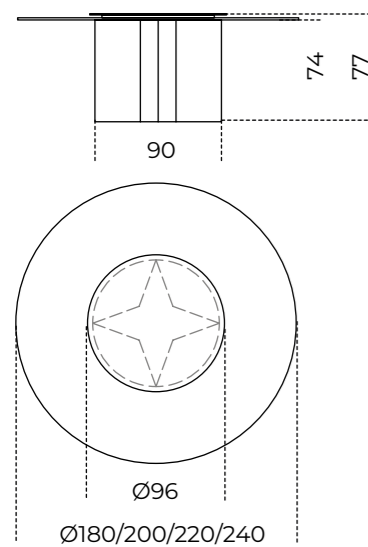

**Vol Sect** | Oscar e Gabriele Buratti, 2020

Product information / p. 66

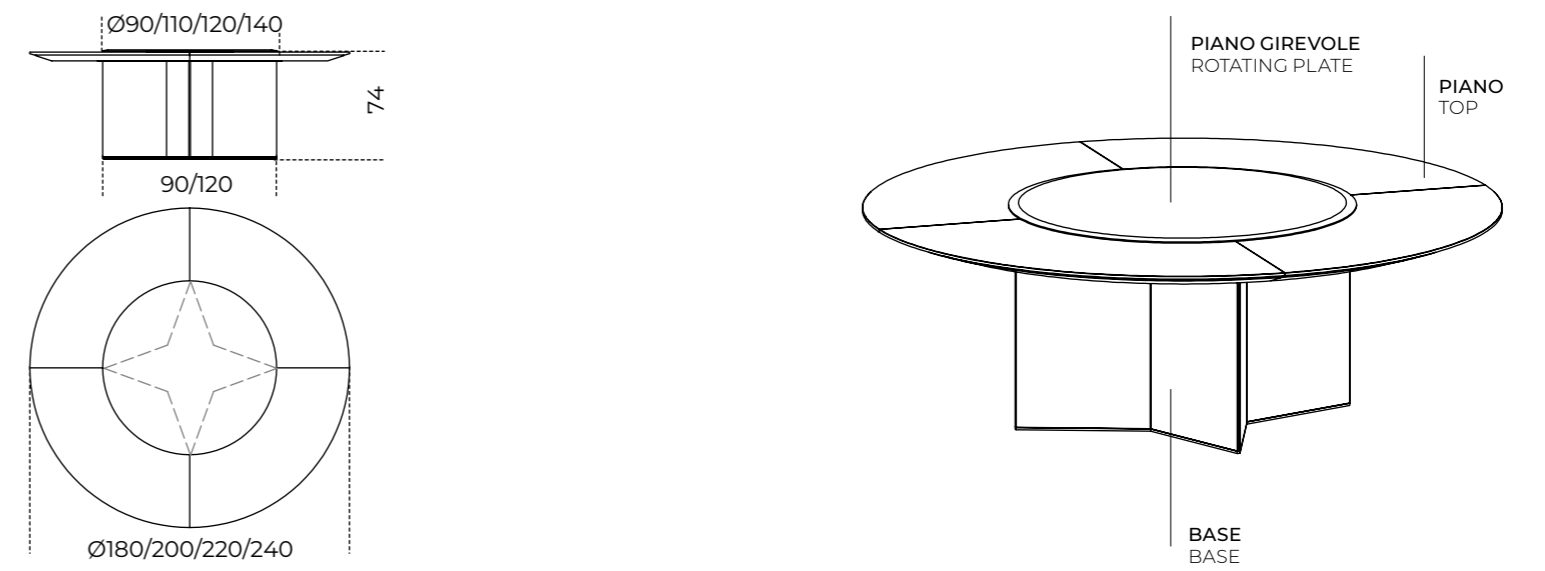

**Zen** | Massimo Castagna, 2018

Product information / p. 70

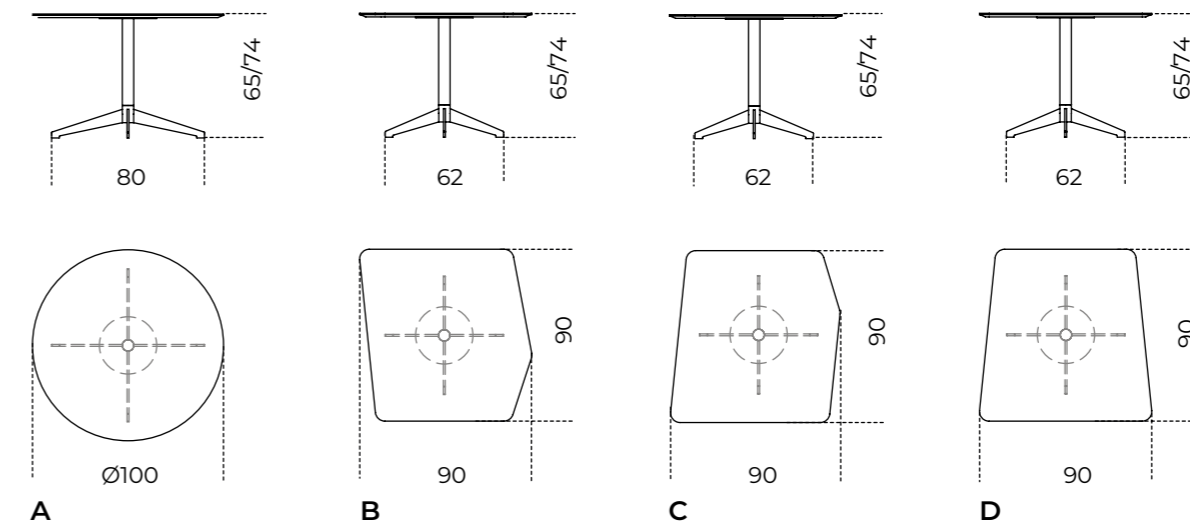

**Zen Black** | Massimo Castagna, 2020

Product information / p. 72

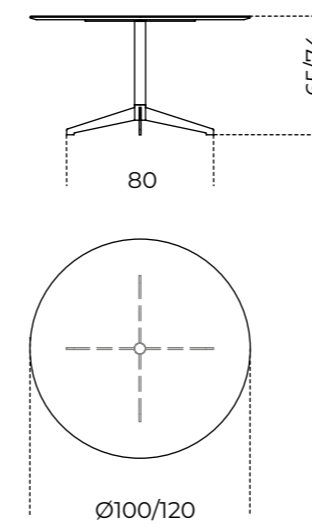

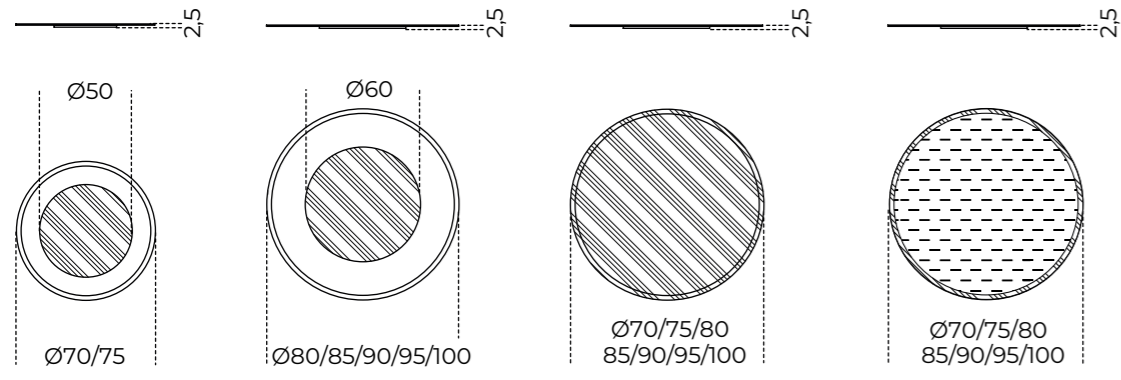

 **Cristallo retroverniciato brillante**  
Bright painted glass

 **Cristallo retroverniciato satinato**  
Satin painted glass

 **Cristallo retroverniciato brillante**  
Bright painted glass

## **02** Sedute / Seatings

94	<b>0414</b>
98	<b>0419</b>
100	<b>Akiko</b>
102	<b>H2O</b>
104	<b>Jackie</b>
106	<b>Janette</b>
108	<b>Keyko</b>
110	<b>Livrette</b>
112	<b>Thea</b>
114	<b>Thea Barstool</b>
116	<b>Thea Queen</b>
118	<b>Informazioni tecniche/ Technical informations</b>



▲ 0414  
Struttura in frassino tinto nero a poro aperto / Rivestimento in Nabuk black 2128  
Black lacquered open pore solid ash structure / Cover in Nabuk black 2128

# 0414

Studio G&R / 2014

Poltroncina con struttura in massello di legno curvato.  
Disponibile in frassino naturale o in frassino tinto nero a poro aperto, tinto tabacco a poro aperto, tinto "Pure" bianco a poro aperto o tinto grigio smoke a poro aperto.

## NEW

Disponibile in frassino tinto creta a poro aperto, tinto wengè a poro aperto o tinto cenere a poro aperto.  
Disponibile anche versione in faggio laccato opaco a poro chiuso nei colori "Bianco Camargue", "Sabbia del Nilo", "Rosa Jaipur", "Bordeaux Etruria" e "Verde Provenza".  
Seduta e schienale con struttura interna in legno e derivati con imbottitura in poliuretano espanso indeformabile a densità differenziate.  
Rivestimento in tessuto o pelle nei colori del campionario.

## ! Non sfoderabile.

Il massello di frassino naturale presenta variazioni di colore che vanno dal biondo chiaro al rosa fino ad arrivare al bruno pallido, con eventuali sfumature di verde. Queste differenze sono da considerarsi caratteristiche di questa essenza.

Il legno massello è molto sensibile alla luce, il posizionamento vicino a sorgenti di luce naturale ne compromette la colorazione e la stabilità. Un'elevata variazione della temperatura e umidità dell'aria può provocare la comparsa di microfratture e leggere variazioni.

Armchair with solid curved wooden structure.  
Available in natural ash or black stained open pore, tobacco stained open pore, "Pure" white stained open pore or grey smoke stained open pore ash.

## NEW

Available in clay stained open pore, wengé stained open pore or cinder stained open pore ash.  
Also available opaque lacquered closed pore beech version in the colours "Bianco Camargue", "Sabbia del Nilo", "Rosa Jaipur", "Bordeaux Etruria" and "Verde Provenza".  
Seat and backrest with internal structure in wood and by-products with padding in non-deformable foam polyurethane in different densities.  
Covered by fabric or leather as per samples.

## ! Not removable cover.

Natural ash solid wood has colour variations ranging from light blonde to pink to pale brown, with possible shades of green. These differences are to be considered characteristic of this essence.

Solid wood is very light-sensitive, placing it near natural light sources may compromise its colour and stability. Considerable differences in air temperature and humidity may cause microfractures and slight variations.



For technical drawing / p. 122

Pricelist 2023 / p. 41  
Homescapes, sense of materials / pp. 60, 96  
Homescapes, embracing beauty / pp. 41, 75  
Homescapes, intimate portraits / pp. 40, 46  
Homescapes, gentle attitude / pp. 15, 17, 81, 83

Cm  
57 x 52 x 75

Inches  
22½" x 20½" x 29¾"

## STRUTTURA/STRUCTURE



Frassino naturale  
Natural ash

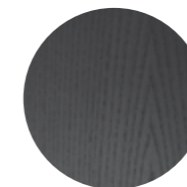

Frassino tinto  
nero a poro aperto  
Black stained  
open pore ash



Frassino tinto tabacco a  
poro aperto  
Tobacco stained  
open pore ash



Frassino tinto "Pure"  
bianco a poro aperto  
"Pure" white open pore  
stained ash



Frassino tinto  
grigio smoke a poro aperto  
Grey smoke open pore  
stained ash

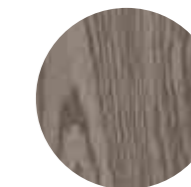

Frassino tinto creta  
a poro aperto  
Clay stained open pore ash

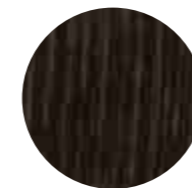

Frassino tinto a  
wengè poro aperto  
Wengé stained  
open pore ash

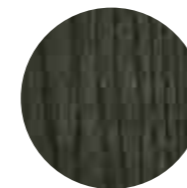

Frassino tinto cenere  
a poro aperto  
Cinder stained  
open pore ash



Faggio laccato opaco a  
poro chiuso  
"Bianco Camargue"  
Opaque lacquered closed  
pore beech  
"Bianco Camargue"



Faggio laccato opaco a  
poro chiuso  
"Sabbia del Nilo"  
Opaque lacquered closed  
pore beech  
"Sabbia del Nilo"

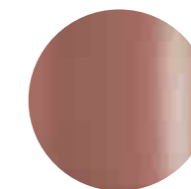

Faggio laccato opaco a  
poro chiuso "Rosa Jaipur"  
Opaque lacquered closed  
pore beech "Rosa Jaipur"

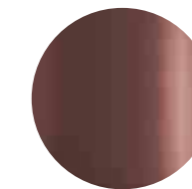

Faggio laccato opaco a  
poro chiuso  
"Bordeaux Etruria"  
Opaque lacquered closed  
pore beech "Bordeaux  
Etruria"

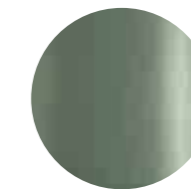

Faggio laccato opaco a  
poro chiuso "Verde Pro-  
venza"  
Opaque lacquered closed  
pore beech "Verde  
Provenza"



Tessuto/pelle nei colori del  
campionario  
Fabric/leather as per  
samples.

## RIVESTIMENTO/COVER

Sample box  
COVERS



**SUGGERIMENTI "TOTAL COLOR"**  
"TOTAL COLOR" SUGGESTIONS

Versione in faggio laccato opaco poro chiuso  
Opaque lacquered closed pore beech version

**"BIANCO CAMARGUE"**



**STRUTTURA/STRUCTURE**



Faggio laccato opaco a poro chiuso  
"Bianco Camargue"  
Opaque lacquered closed pore beech  
"Bianco Camargue"

**RIVESTIMENTO/COVER**



Maze ivory 002 - cat. B  
Maze ivory 002 - cat. B

**"ROSA JAIPUR"**



**STRUTTURA/STRUCTURE**

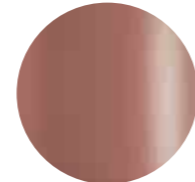

Faggio laccato opaco a poro chiuso  
"Rosa Jaipur"  
Opaque lacquered closed pore beech  
"Rosa Jaipur"

**RIVESTIMENTO/COVER**



Pleasure rose powder 031 - cat. D  
Pleasure rose powder - cat. D

**SUGGERIMENTI "TOTAL COLOR"**  
"TOTAL COLOR" SUGGESTIONS

Versione in frassino tinto poro aperto  
Stained open pore version

**TINTO CENERE**



**STRUTTURA/STRUCTURE**

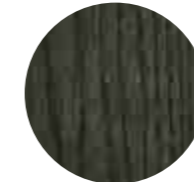

Frassino tinto cenere a poro aperto  
Cinder stained open pore ash

**RIVESTIMENTO/COVER**



Soul silt 027 - cat. B  
Soul silt 027 - cat. B

**TINTO TABACCO**



**STRUTTURA/STRUCTURE**



Frassino tinto tabacco a poro aperto  
Tobacco stained open pore ash

**RIVESTIMENTO/COVER**



Fard anthracite 2379 - cat. L1  
Fard anthracite 2379 - cat. L1

**"BORDEAUX ETRURIA"**



**STRUTTURA/STRUCTURE**



Faggio laccato opaco a poro chiuso  
"Bordeaux Etruria"  
Opaque lacquered closed pore beech  
"Bordeaux Etruria"

**RIVESTIMENTO/COVER**

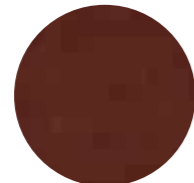

Velvet sienna 014 - cat. A  
Velvet sienna 014 - cat. A

**"VERDE PROVENZA"**



**STRUTTURA/STRUCTURE**

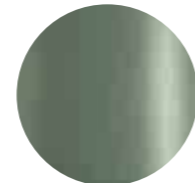

Faggio laccato opaco a poro chiuso  
"Verde Provenza"  
Opaque lacquered closed pore beech  
"Verde Provenza"

**RIVESTIMENTO/COVER**



Pleasure acquamarine 003 - cat. D  
Pleasure acquamarine 003 - cat. D

**TINTO SMOKE**



**STRUTTURA/STRUCTURE**



Frassino tinto grigio smoke  
a poro aperto  
Grey smoke open pore stained ash

**RIVESTIMENTO/COVER**



Path anthracite 118 - cat. B  
Path anthracite 118 - cat. B

**TINTO NERO**



**STRUTTURA/STRUCTURE**

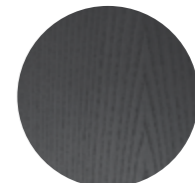

Frassino tinto nero a poro aperto  
Black stained open pore ash

**RIVESTIMENTO/COVER**



Nabuk black 2128 - cat. L2  
Nabuk black 2128 - cat. L2

Versione in frassino tinto poro aperto  
Stained open pore version

**TINTO CRETA**



**STRUTTURA/STRUCTURE**

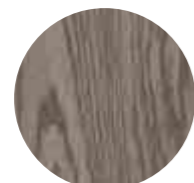

Frassino tinto creta a poro aperto  
Clay stained open pore ash

**RIVESTIMENTO/COVER**



Fard silt 2324 - cat. L1  
Fard silt 2324 - cat. L1

**TINTO WENGÈ**



**STRUTTURA/STRUCTURE**

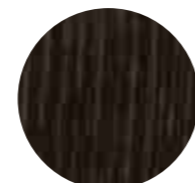

Frassino tinto wengè a poro aperto  
Wengè stained open pore ash

**RIVESTIMENTO/COVER**



Harmony slate 303 - cat. B  
Harmony slate 303 - cat. B

**TINTO BIANCO**



**STRUTTURA/STRUCTURE**



Frassino tinto "Pure" bianco  
a poro aperto  
"Pure" white open pore stained ash

**RIVESTIMENTO/COVER**



Delight cream 109 - cat. A  
Delight cream 109 - cat. A

**NATURALE**



**STRUTTURA/STRUCTURE**



Frassino naturale  
Natural ash

**RIVESTIMENTO/COVER**



Gape ecru 004 - cat. A  
Gape ecru 004 - cat. A

**STRUTTURA/STRUCTURE**



# 0419

Studio G&R / 2019

Sgabello con struttura in massello di frassino curvato tinto nero a poro aperto e poggiatesta in metallo laccato grigio antracite.

Disponibile anche in frassino naturale, tinto tabacco a poro aperto, tinto "Pure" bianco a poro aperto o tinto grigio smoke a poro aperto.

Seduta e schienale con struttura interna in legno e derivati con imbottitura in poliuretano espanso indeformabile a densità differenziate. Rivestimento in tessuto o pelle nei colori del campionario.

! Non sfoderabile.

Il massello di frassino naturale presenta variazioni di colore che vanno dal biondo chiaro al rosa fino ad arrivare al bruno pallido, con eventuali sfumature di verde. Queste differenze sono da considerarsi caratteristiche di questa essenza.

Il legno massello è molto sensibile alla luce, il posizionamento vicino a sorgenti di luce naturale ne compromette la colorazione e la stabilità. Un'elevata variazione della temperatura e umidità dell'aria può provocare la comparsa di microfessure e leggere variazioni.

Stool with black stained open pore solid curved ash structure and anthracite grey lacquered metal footrest. Also available in natural ash, tobacco stained open pore, "Pure" white stained open pore or grey smoke stained open pore ash.

Seat and backrest with internal structure in wood and byproducts with padding in non-deformable foam polyurethane in different densities. Covered by fabric or leather as per samples.

! Not removable cover.

Natural ash solid wood has colour variations ranging from light blonde to pink to pale brown, with possible shades of green. These differences are to be considered characteristic of this essence.

Solid wood is very light-sensitive, placing it near natural light sources may compromise its colour and stability. Considerable differences in air temperature and humidity may cause microfractures and slight variations.



**Cm**

57 x 52 x 92  
57 x 52 x 102

**Inches**

22½" x 20¼" x 36¼"  
22½" x 20¼" x 40¼"

For technical drawing / p. 122

Pricelist 2023 / p. 42

**STRUTTURA/STRUCTURE**

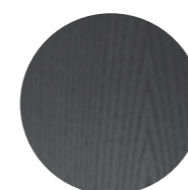

**Frassino tinto nero a poro aperto**  
Black stained open pore ash



**Frassino naturale**  
Natural ash



**Frassino tinto tabacco a poro aperto**  
Tobacco stained open pore ash



**Frassino tinto "Pure" bianco a poro aperto**  
"Pure" white open pore stained ash



**Frassino tinto grigio smoke a poro aperto**  
Grey smoke open pore stained ash

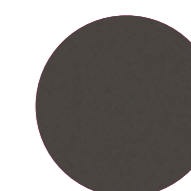

**Metallo laccato grigio antracite**  
Anthracite grey lacquered metal

**POGGIAPIEDI/FOOTREST**

**RIVESTIMENTO/COVER**



**Tessuto/pelle nei colori del campionario**  
Fabric/leather as per samples.

▲ 0419

Struttura in frassino tinto nero a poro aperto / Rivestimento in leather Tobacco 013  
Black lacquered open pore solid ash structure / Cover in leather Tobacco 013

# Akiko

Oscar e Gabriele Buratti / 2021



Sedia con struttura interna in legno imbottita con poliuretano espanso indeformabile a densità differenziate e fibra poliestere. Basamento in metallo verniciato color "warm grey". Rivestimento in tessuto o pelle nei colori del campionario.  
Non sfoderabile.  
Disponibile versione con movimento girevole a 180° con ritorno con basamento a 4 razze in metallo verniciato color "warm grey" con finalini.

! Non sfoderabile.

Chair with inside structure in wood padded with non-deformable polyurethane foam in different density and polyester fibre. Metal base lacquered in "warm grey" colour. Covered by fabric or leather as per samples.  
Not removable cover.  
Also available version with 180° swivel movement with return with "warm grey" colour lacquered four star metal base with feet.

! Not removable cover.



**Cm**  
59 x 57 x 77

**Inches**  
23¼" x 22½" x 30½"

For technical drawing / p. 122

Pricelist 2023 / p. 43  
Homescapes, intimate portraits / pp. 82, 85  
Homescapes, gentle attitude / pp. 28, 30, 34, 45, 90

**BASE METALLICA/  
METAL BASE**

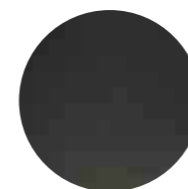

Metallo verniciato  
"warm grey"  
Metal lacquered  
"warm grey" colour

**RIVESTIMENTO/COVER**



Tessuto/pelle nei colori del  
campionario  
Fabric/leather as per  
samples.



▲ H20  
Rivestimento in Fard silt 2324  
Cover in Fard silt 2324

# H20

Studiopepe / 2024

Poltroncina con struttura interna in metallo imbottita con poliuretano espanso indeformabile a densità differenziate. Completamente rivestita in tessuto o in pelle nei colori del campionario.  
Non sfoderabile.  
Su richiesta rivestimento sfoderabile, non disponibile per le seguenti categorie: Cat. L1, L2 e pelle cliente/C.O.L.  
L'abbinamento delle cerniere viene definito da Gallotti&Radice coordinandolo con il rivestimento scelto.

! Non sfoderabile.

Su richiesta rivestimento sfoderabile escluso Cat. L1, L2 e pelle cliente/C.O.L.

Per la realizzazione di elementi con rivestimento in pelle sono necessarie cuciture aggiuntive rispetto gli elementi con rivestimento in tessuto.

Armchair with metal inside structure padded with non-deformable polyurethane foam in different density. Completely covered by fabric or leather as per samples.  
Not removable cover.  
Removable covers upon request, not available for the following categories: Cat. L1, L2 and customer leather C.O.L.  
The colour combination of the zip is defined by Gallotti&Radice by matching it with the chosen covering.

! Not removable cover.

On demand removable covers excluding Cat. L1, L2 and customer leather C.O.L.

Additional stitching is required for elements with leather upholstery compared to elements with fabric upholstery.



For technical drawing / p.123

**Cm**  
62,5 x 52,3 x 69

**Inches**  
24¾" x 20¾" x 27¼"

## RIVESTIMENTO/COVER



Tessuto/pelle nei colori del campionario  
Fabric/leather as per samples.



# Jackie

Stefano Bigi / 2014

Sedia con struttura interna in legno e derivati imbottita con poliuretano espanso indeformabile a densità differenziate e fibra poliestere. Disponibile versione con braccioli. Completamente rivestita in tessuto o in pelle nei colori del campionario. A richiesta versione con gambe in frassino laccato nero poro aperto. Disponibile versione "loungè" (solo per poltroncina) con altezza della seduta 40cm. Non sfoderabile.

! Non sfoderabile.

Upholstered chair with inside structure in wood and by-products. Padded with non-deformable polyurethane foam in different density and polyester fibre. Available version with armrests. Completely covered by fabric or leather as per samples. On request version with black open pore lacquered ash legs. Also available "loungè" version (only for armchair) with seat's height cm 40. Not removable cover.

! Not removable cover.



**Cm**  
54 x 56 x 80  
54 x 56 x 73 (loungè)

**Inches**  
21½" x 22¼" x 31½"  
21½" x 22¼" x 28¾" (loungè)

For technical drawing / p.123

Pricelist 2023 / p. 44  
Homesapes, embracing beauty / pp. 15, 48

## RIVESTIMENTO/COVER



Tessuto/pelle nei colori del campionario  
Fabric/leather as per samples.

## STRUTTURA/STRUCTURE



Tessuto/pelle nei colori del campionario  
Fabric/leather as per samples.

## GAMBE/LEGS

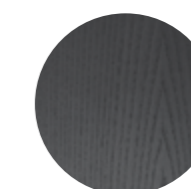

Frassino laccato nero a poro aperto  
Black lacquered open pore ash



# Janette

Federica Biasi / 2023

Poltroncina con struttura interna in legno imbottita con poliuretano espanso indeformabile a densità differenziate e fibra poliestere. Completamente rivestita in tessuto o in pelle nei colori del campionario. Zoccolo in metallo nichelato nero.

! Non sfoderabile.

Armchair with inside structure in wood padded with non-deformable polyurethane foam in different density and polyester fibre. Completely covered by fabric or leather as per samples. Plinth in black nickel-plated metal.

! Not removable cover.



**Cm**  
70 x 57 x 78,5

**Inches**  
27¾" x 22½" x 31

For technical drawing / p.123

Pricelist 2023 / p. 48  
Homescapes, embracing beauty / pp. 15, 48

## RIVESTIMENTO/COVER



Tessuto/pelle nei colori del campionario  
Fabric/leather as per samples.

## ZOCCOLO/PLINTH

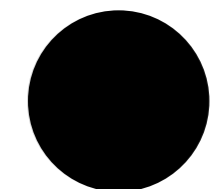

Metallo nichelato nero  
Black nickel-plated metal



• **KEYKO**  
Struttura in frassino tinto nero a poro aperto / Rivestimento in Tokyo tabacco 203  
Black lacquered open pore ash structure / Cover in Tokyo tabacco 203

# Keyko

Pinuccio Borgonovo / 2017

Sedia con struttura in massello di frassino tinto nero a poro aperto.

Disponibile anche in frassino naturale, tinto tabacco a poro aperto o tinto "Pure" bianco a poro aperto.

Seduta con struttura interna in legno e derivati imbottita in poliuretano espanso indeformabile. Schienale in poliuretano strutturale annegato in schiuma poliuretana flessibile. Rivestimento in tessuto o pelle nei colori del campionario.

! Non sfoderabile.

Il massello di frassino naturale presenta variazioni di colore che vanno dal biondo chiaro al rosa fino ad arrivare al bruno pallido, con eventuali sfumature di verde. Queste differenze sono da considerarsi caratteristiche di questa essenza.

Il legno massello è molto sensibile alla luce, il posizionamento vicino a sorgenti di luce naturale ne compromette la colorazione e la stabilità. Un'elevata variazione della temperatura e umidità dell'aria può provocare la comparsa di microfratture e leggere variazioni.

Chair with black open pore stained solid ash structure.

Also available in natural ash, tobacco stained open pore or "Pure" white open pore stained ash.

Seat with inside structure in wood and by-products padded in non-deformable polyurethane foam. Backrest made of structural polyurethane dipped in flexible polyurethane foam. Covered by fabric or leather as per samples.

! Not removable cover.

Natural ash solid wood has colour variations ranging from light blonde to pink to pale brown, with possible shades of green. These differences are to be considered characteristic of this essence.

Solid wood is very light-sensitive, placing it near natural light sources may compromise its colour and stability. Considerable differences in air temperature and humidity may cause microfractures and slight variations.



**Cm**  
53 x 51 x 74,5

**Inches**  
21" x 20¼" x 29½"

For technical drawing / p. 124

Pricelist 2023 / p. 46  
Homescapes, embracing beauty / pp. 36, 53  
Homescapes, intimate portraits / p. 98

## STRUTTURA/STRUCTURE

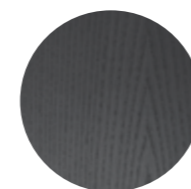

Frassino tinto  
nero a poro aperto  
Black stained  
open pore ash



Frassino tinto tabacco a  
poro aperto  
Tobacco stained  
open pore ash



Frassino naturale  
Natural ash



Frassino tinto "Pure"  
bianco a poro aperto  
"Pure" white open pore  
stained ash

## RIVESTIMENTO/COVER



Tessuto/pelle nei colori del  
campionario  
Fabric/leather as per  
samples.

# Livrette

Federica Biasi / 2021

Poltroncina con struttura interna in legno imbottita con poliuretano espanso indeformabile a densità differenziate e fibra poliestere. Basamento in massello di frassino tinto nero a poro aperto. Rivestimento in tessuto o pelle nei colori del campionario.

! Non sfoderabile.

! Il legno massello è molto sensibile alla luce, il posizionamento vicino a sorgenti di luce naturale ne compromette la colorazione e la stabilità. Un'elevata variazione della temperatura e umidità dell'aria può provocare la comparsa di microfratture e leggere variazioni.

Armchair with inside structure in wood padded with non-deformable polyurethane foam in different density and polyester fibre. Black open pore stained solid ash base. Covered by fabric or leather as per samples.

! Not removable cover.

! Solid wood is very light-sensitive, placing it near natural light sources may compromise its colour and stability. Considerable differences in air temperature and humidity may cause microfractures and slight variations.



**Cm**  
65 x 55 x 72

**Inches**  
25¾" x 21¾" x 28½"

For technical drawing / p. 124

Pricelist 2023 / p. 47  
Homescapes, intimate portraits / pp. 33, 74

## BASE/BASE

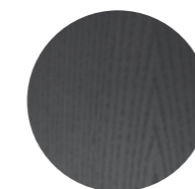

Frassino tinto  
nero a poro aperto  
Black stained  
open pore ash

## RIVESTIMENTO/COVER



Tessuto/pelle nei colori del  
campionario  
Fabric/leather as per  
samples.



# Thea

Pinuccio Borgonovo / 2015

Sedia con struttura interna in legno e derivati, imbottita in poliuretano espanso indeformabile a densità differenziate e fibra poliestere. Rivestimento in tessuto o pelle nei colori del campionario. Gambe in rovere laccato nero a poro aperto. Non sfoderabile.

! Non sfoderabile.

Chair with inside structure in wood and by-products padded in non-deformable foam polyurethane in different density and polyester fibre. Covered by fabric or leather as per samples. Black open pore lacquered oak legs. Not removable cover.

! Not removable cover.



**Cm**  
50 x 57 x 80

**Inches**  
19¾" x 22½" x 31½"

For technical drawing / p. 124

Pricelist 2023 / p. 49  
Homescapes, sense of materials / p. 44  
Homescapes, intimate portraits / p. 29

## RIVESTIMENTO/COVER



Tessuto/pelle nei colori del campionario  
Fabric/leather as per samples.

## STRUTTURA E GAMBE/ STRUCTURE AND LEGS

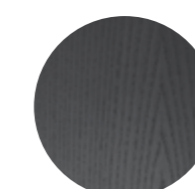

Rovere laccato nero a poro aperto  
Black open pore lacquered oak

▲ THEA  
Gambe in rovere tinto nero a poro aperto / Rivestimento in velvet Sage green 6381  
Black open pore lacquered oak legs / Cover in velvet Sage green 6381



• THEA BARSTOOL  
Gambe in rovere tinto nero poro aperto / Rivestimento in Fard antracite 2379  
Black open pore lacquered oak legs / Cover in Fard anthracite 2379

# Thea Barstool

Pinuccio Borgonovo / 2024

Sgabello con struttura interna in legno e derivati, imbottita in poliuretano espanso indeformabile a densità differenziate e fibra poliestere. Rivestimento in tessuto o pelle nei colori del campionario. Gambe in rovere laccato nero a poro aperto. Poggiapiedi in metallo laccato grigio antracite.

! Non sfoderabile.

Stool with inside structure in wood and by-products padded in non-deformable foam polyurethane in different density and polyester fibre. Covered by fabric or leather as per samples. Black open pore lacquered oak legs. Anthracite grey lacquered metal footrest

! Not removable cover.



**Cm**  
50 x 55 x 99

**Inches**  
19¾" x 21¾" x 39"

[For technical drawing / p.125](#)

## RIVESTIMENTO/COVER



Tessuto/pelle nei colori del campionario  
Fabric/leather as per samples.

## STRUTTURA E GAMBE/ STRUCTURE AND LEGS

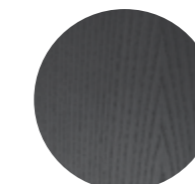

Rovere laccato  
nero a poro aperto  
Black open pore  
lacquered oak

## POGGIAPIEDI/FOOTREST

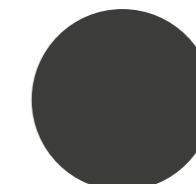

Metallo laccato  
grigio antracite  
Anthracite grey  
lacquered metal



▲ **THEA QUEEN**  
 Gambe in rovere tinto nero a poro aperto / Rivestimento in velvet Mink 518  
 Black open pore lacquered oak legs / Cover in velvet Mink 518

# Thea Queen

Pinuccio Borgonovo / 2016

Poltroncina con struttura interna in legno e derivati imbottita in poliuretano espanso indeformabile a densità differenziate e fibra poliestere. Rivestimento in tessuto o pelle nei colori del campionario. Gambe in rovere laccato nero a poro aperto. Disponibile versione "lounge".

! Non sfoderabile.

Armchair with inside structure in wood and by-products padded in non-deformable foam polyurethane in different density and polyester fibre. Covered by fabric or leather as per samples. Black open pore lacquered oak legs. Also available "lounge" version.

! Not removable cover.



**Cm**  
 63 x 63 x 80  
 63 x 63 x 71 (lounge)

**Inches**  
 25" x 25" x 31½"  
 25" x 25" x 28" (lounge)

For technical drawing / p. 125

Pricelist 2023 / p. 50  
 Homescapes, sense of materials / p. 110

## RIVESTIMENTO/COVER



Tessuto/pelle nei colori del campionario  
 Fabric/leather as per samples.

## STRUTTURA E GAMBE/ STRUCTURE AND LEGS

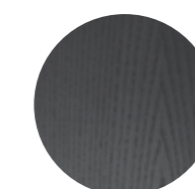

Rovere laccato nero a poro aperto  
 Black open pore lacquered oak

# 02

**Sedute / Seating**  
**TECHNICAL MODULE**



0414 | Studio G&R, 2014

Product information / p.94

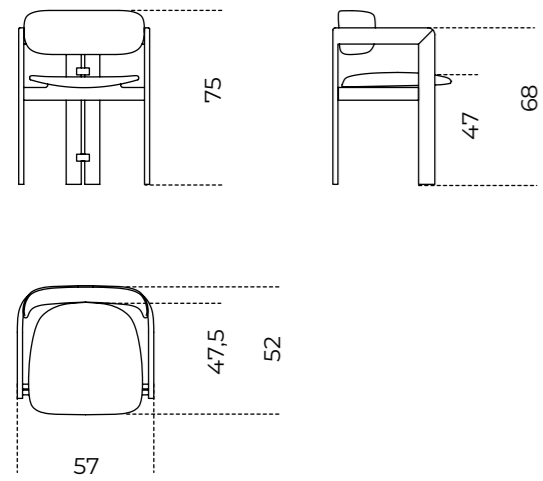

H2O | Studiopepe, 2024

Product information / p.102

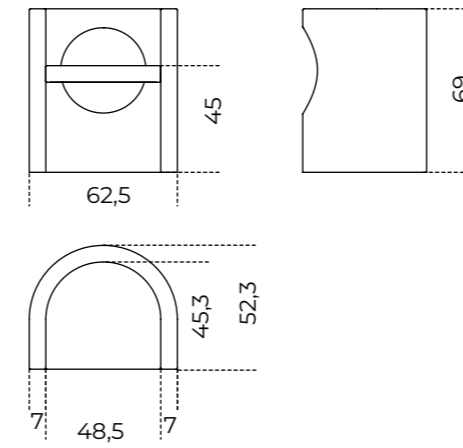

0419 | Studio G&R, 2019

Product information / p.98

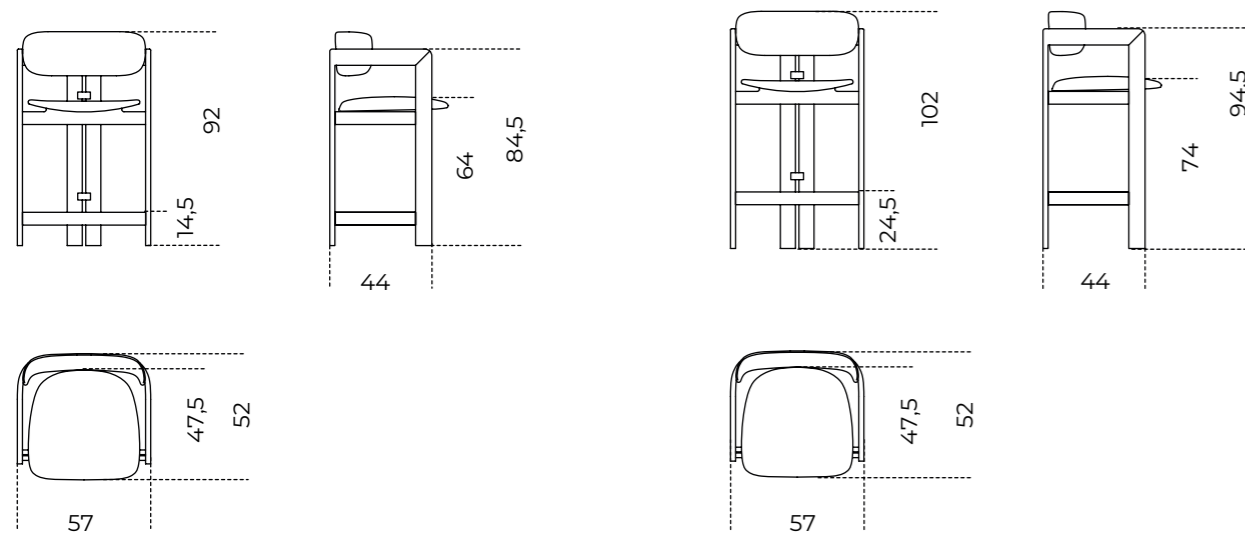

Jackie | Stefano Bigi, 2014

Product information / p.104

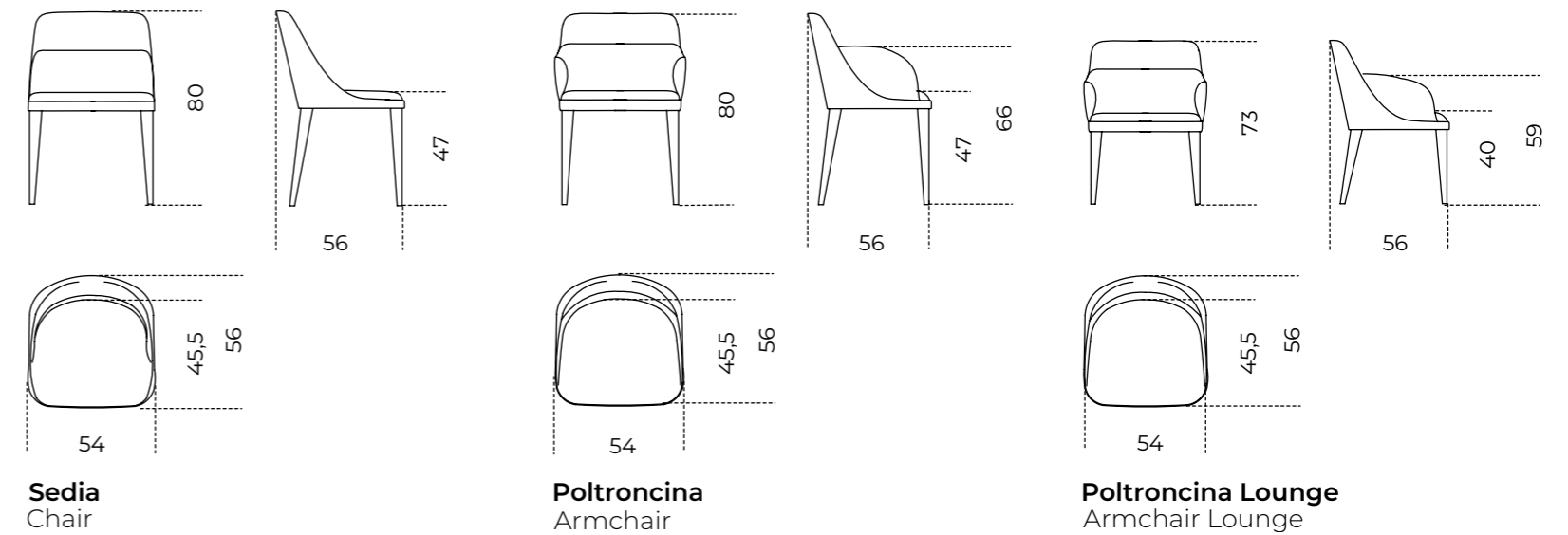

Akiko | Oscar e Gabriele Buratti, 2021

Product information / p.100

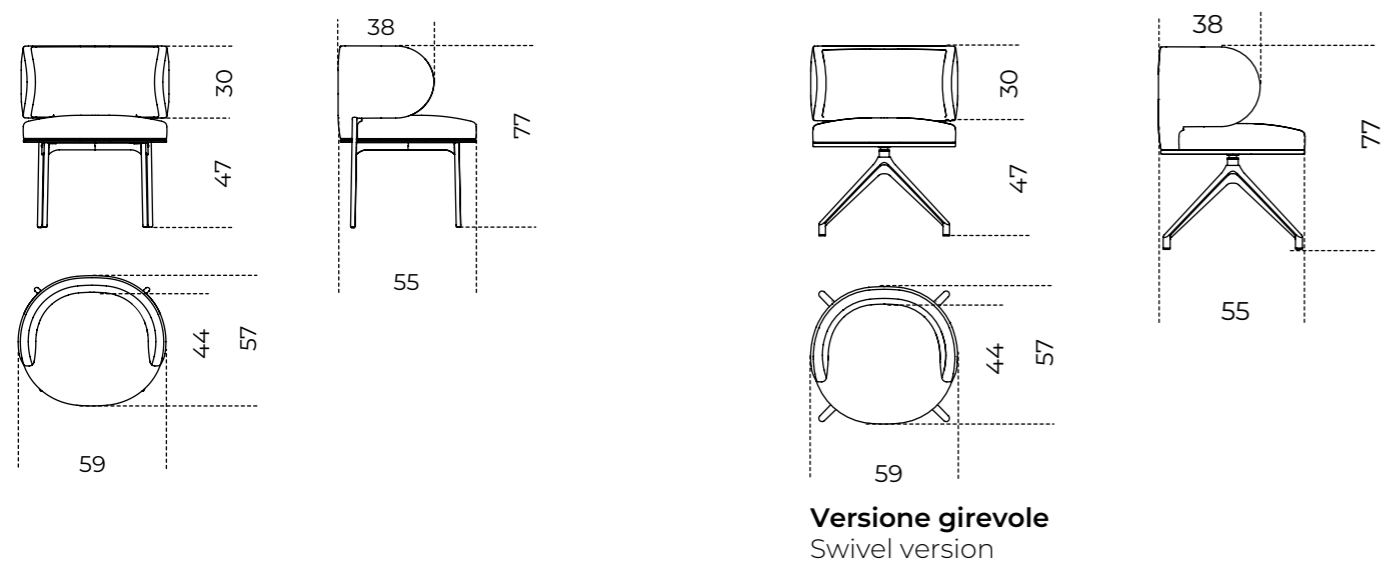

Janette | Federica Biasi, 2023

Product information / p.106

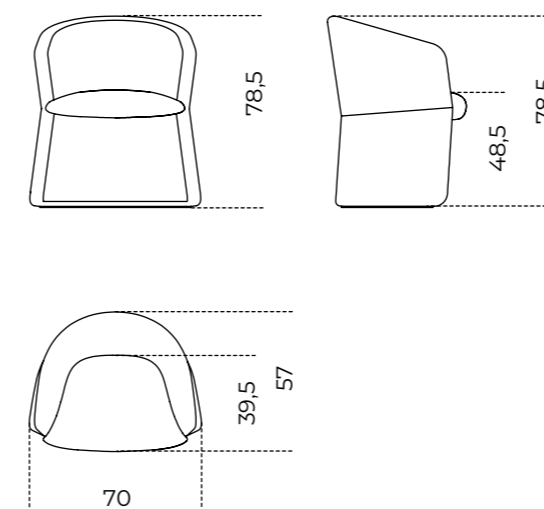

**Keyko** | Pinuccio Borgonovo, 2017

[Product information / p. 108](#)

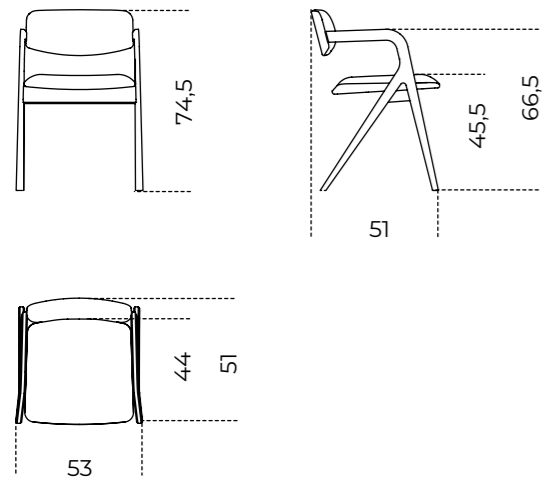

**Thea Barstool** | Pinuccio Borgonovo, 2024

[Product information / p. 114](#)

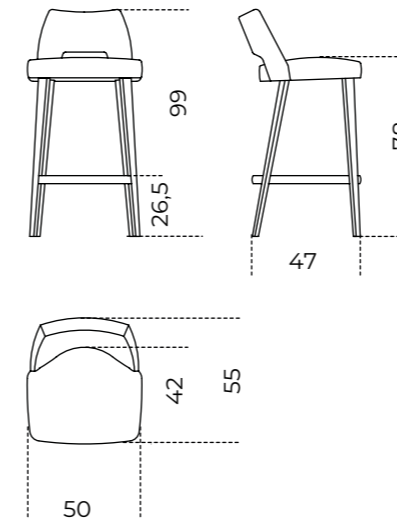

**Livrette** | Federica Biasi, 2021

[Product information / p. 110](#)

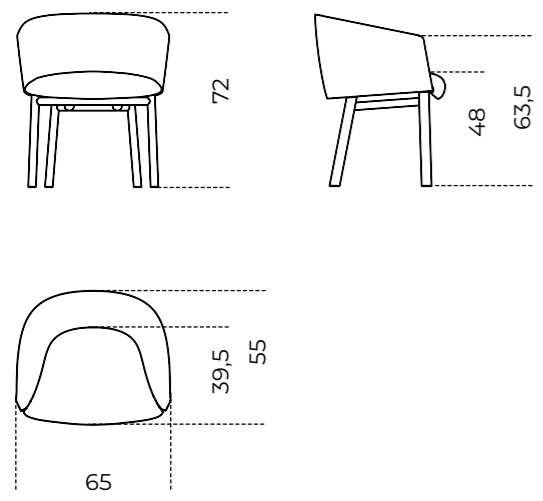

**Thea Queen** | Pinuccio Borgonovo, 2016

[Product information / p. 116](#)

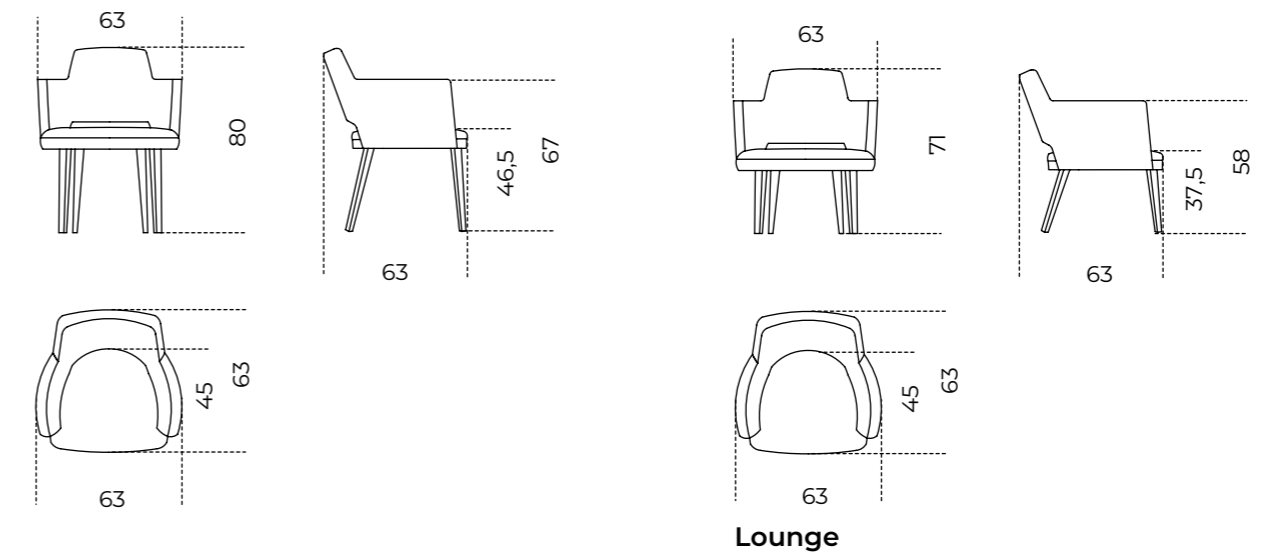

**Thea** | Pinuccio Borgonovo, 2015

[Product information / p. 112](#)

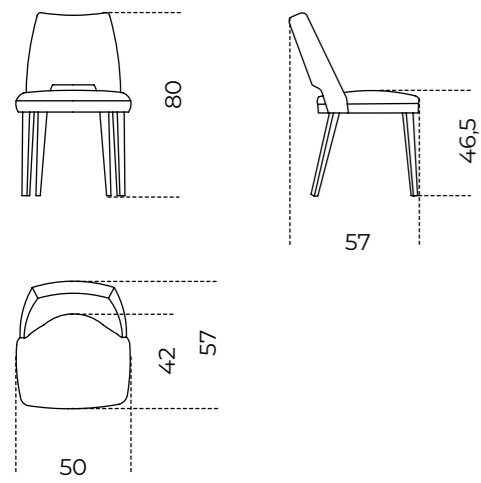

**Lounge**

**03 Carrelli /**  
Trolleys

128 Mister

130 Riki

132 Informazioni tecniche/  
Technical informations



# Mister

Andreas Weber / 1998

Carrello in cristallo trasparente 10mm. Su richiesta cristallo retroverniciato nei colori del campionario nella versione brillante o satinata. Struttura in acciaio inox lucido o satinato. Maniglie in rovere sbiancato, tinto wengé, tinto tabacco o rovere laccato nero a poro aperto. Disponibili versioni "total color" con struttura bianco, grigio o nero opaco con piani in cristallo retroverniciato satinato nello stesso colore della struttura.

Trolley in 10mm transparent glass. Painted glass as per samples in the bright or satin version, on request. Bright or satin stainless steel metal parts. Handles in whitened oak, wengé stained, tobacco stained or black open pore lacquered oak. Available versions "total color" with lacquered structure opaque white, opaque grey and opaque black with satin painted glass tops in the same colour of the structure.



**Cm**  
84 x 48 x 82

**Inches**  
33¼" x 19" x 32½"

[For technical drawing / p.134](#)

[Pricelist 2023 / p.194](#)  
[Homescapes, intimate portraits / pp.41,45](#)

## PIANI/TOPS



**Cristallo trasparente**  
Transparent glass



**Sample box**

**Cristallo brillante/satinato nei colori del campionario**  
Glass bright/satin version as per samples

## STRUTTURA/STRUCTURE



**Acciaio inox lucido/satinato**  
Bright/Satin stainless steel

## MANIGLIE/HANDLES



**Rovere sbiancato**  
Whitened oak



**Rovere tinto wengé a poro aperto**  
Wengé open pore stained oak



**Rovere tinto tabacco a poro aperto**  
Tobacco open pore stained oak

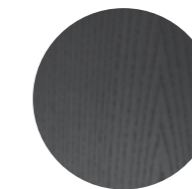

**Rovere laccato nero a poro aperto**  
Black open pore lacquered oak

## "TOTAL COLOR" VERSION

### STRUTTURA E MANIGLIE/STRUCTURE AND HANDLES

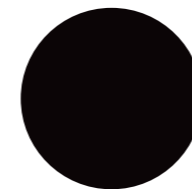

**"Total color" nero opaco**  
"Total color" opaque black



**"Total color" grigio umbro opaco**  
"Total color" opaque dark grey



**"Total color" bianco opaco**  
"Total color" opaque white

## PIANI/TOPS

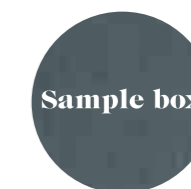

**Cristallo retroverniciato satinato nello stesso colore della struttura**  
Satin painted glass tops in the same colour of the structure.

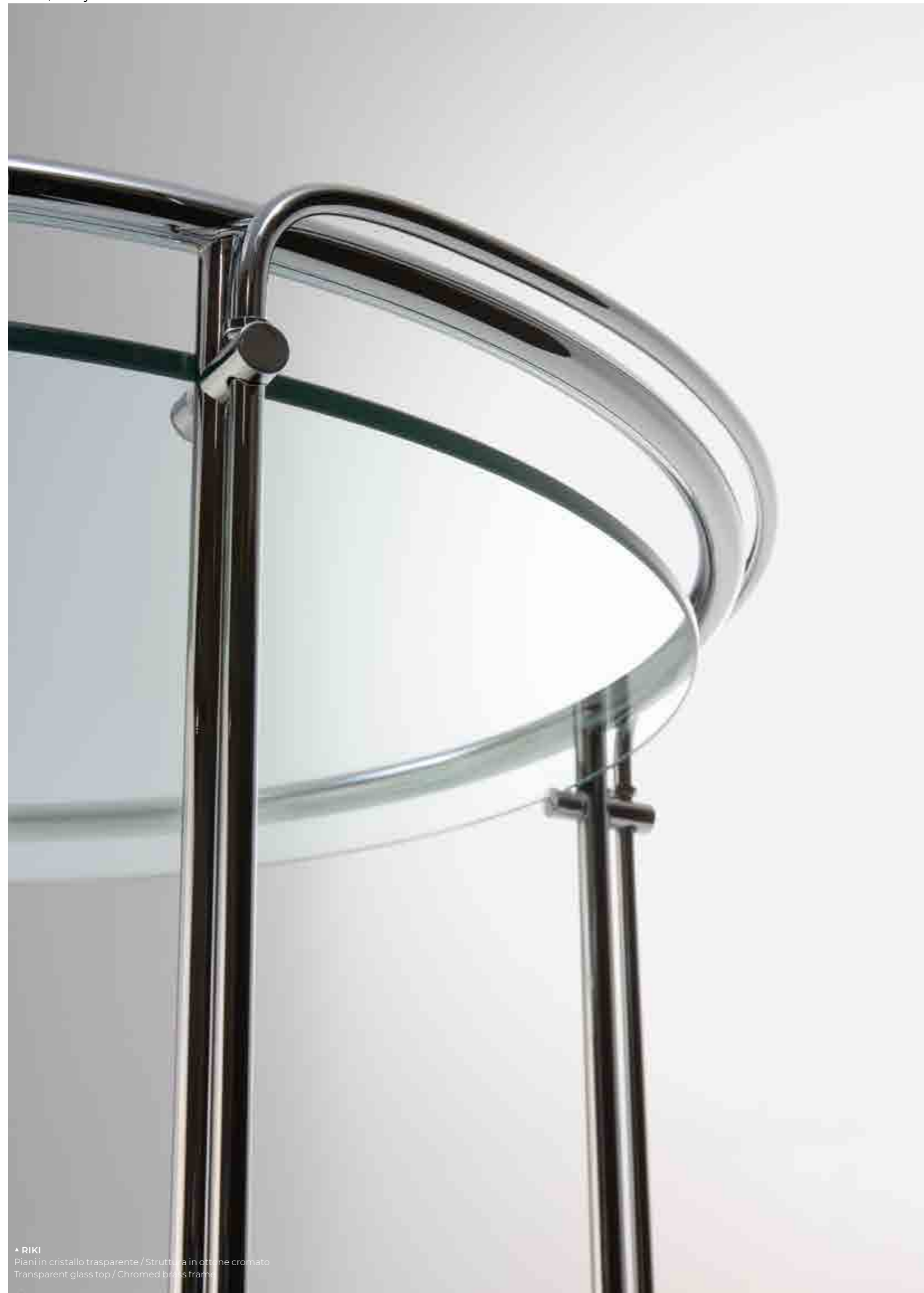

▲ RIKI  
Piani in cristallo trasparente / Struttura in ottone cromato  
Transparent glass top / Chromed brass frame

# Riki

Pierangelo Gallotti / 1971

Carrello in cristallo trasparente o extralight 8mm. Su richiesta cristallo retroverniciato nei colori del campionario nella versione brillante o satinata. Struttura in ottone cromato. A richiesta ottone lucido o satinato.

Trolley in 8mm transparent or extralight glass. Painted glass as per samples in the bright or satin version on request. Chromed brass frame. Bright or satin brass frame on request.



	Cm	Inches
T52/1	82 x 38 x 69	32½" x 15" x 27¼"
T52/2	96 x 46 x 69	38" x 18¼" x 27¼"
T53	Ø 60 x 69	Ø 23¾" x 27¼"

[For technical drawing / p. 134](#)

[Pricelist 2023 / p. 196](#)  
[Homescapes, embracing beauty / p. 16](#)  
[Homescapes, intimate portraits / p. 31](#)

## PIANO/TOP



Cristallo trasparente  
Transparent glass



Cristallo extralight  
Extralight glass

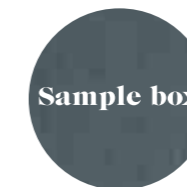

Cristallo brillante/satinato  
nei colori del campionario  
Glass bright/satin version as  
per samples

## STRUTTURA/STRUCTURE



Ottone cromato  
Chrome



Ottone lucido  
Bright brass



Ottone satinato  
Satin brass

# 03

**Carrelli / Trolleys**  
**TECHNICAL MODULE**

Mister | Andreas Weber, 1998

Product information / p. 128

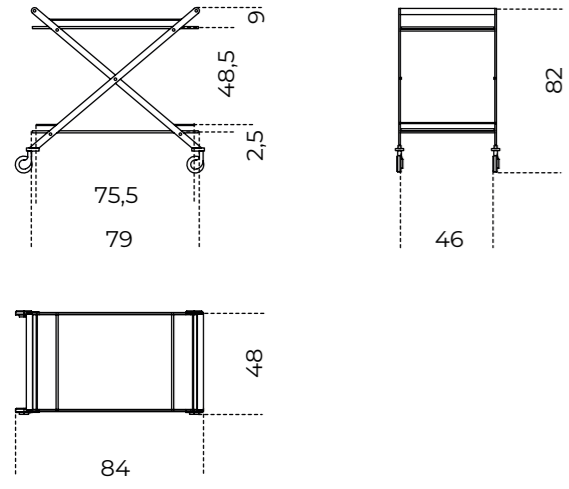

Riki | Pierangelo Gallotti, 1971

Product information / p. 130

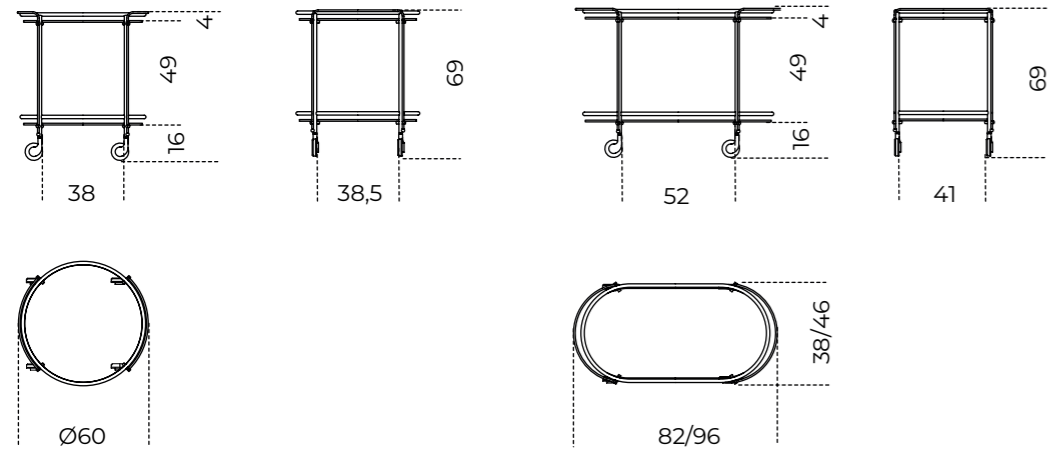

T53

T52/1  
T52/2

## **04** Panche e Pouf /

Benches and Pouffe

138 **Audrey Pouf**

140 **Cloud Pouf**

142 **Lilas Bench**

144 **Lou**

146 **Oly**

148 **Sensei Bench**

150 **Stami Bench**

152 **Stami DayBed**

154 **Stami Pouf**

156 **Twelve DayBed**

158 **Informazioni tecniche/**

**Technical informations**

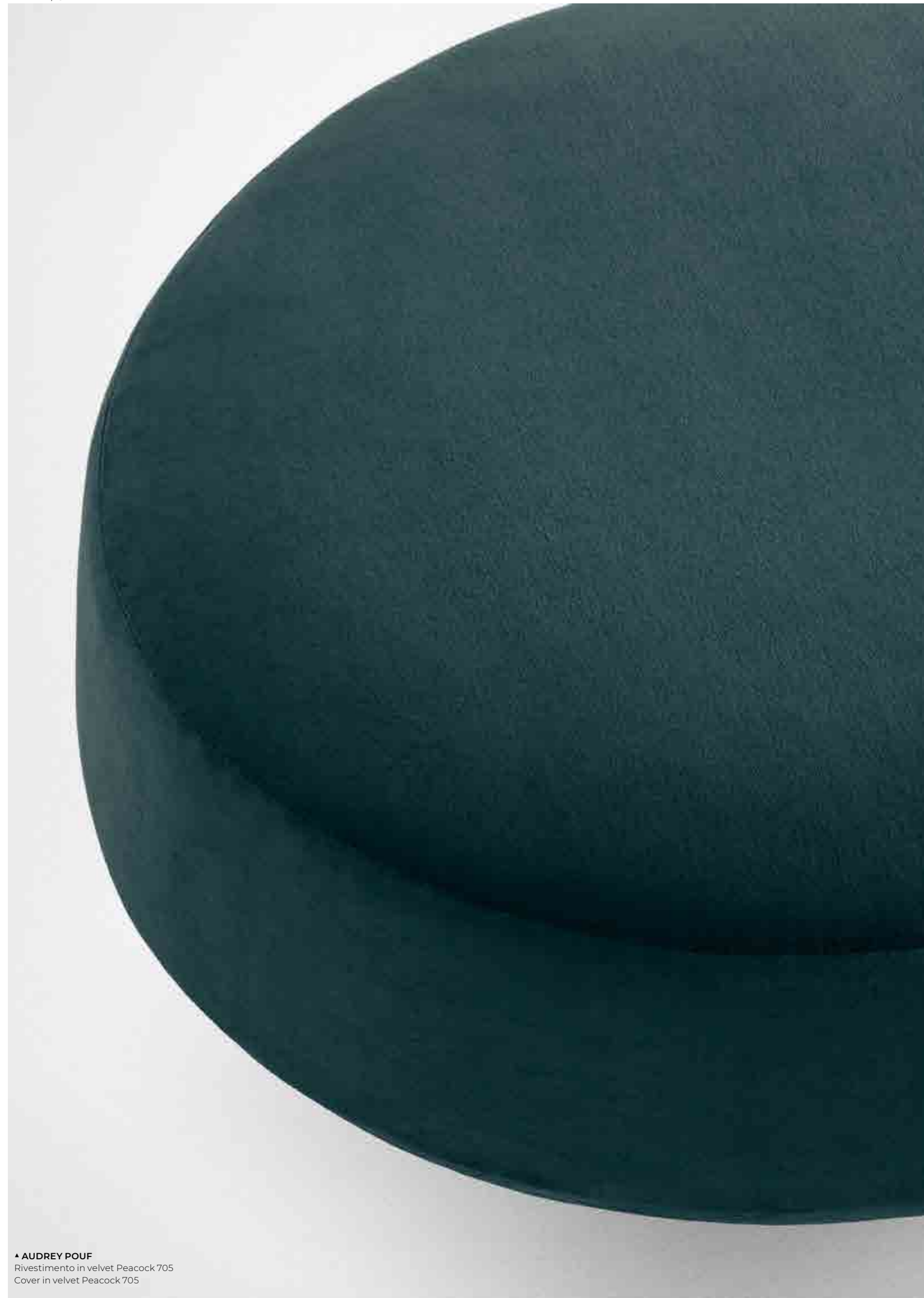

• **AUDREY POUF**  
Rivestimento in velvet Peacock 705  
Cover in velvet Peacock 705

# Audrey Pouf

Massimo Castagna / 2019

Pouf in poliuretano espanso indeformabile a densità differenziate e fibra poliestere con struttura interna legno. Basamento in MDF in massa nero. Disponibile con rivestimento in tessuto o pelle nei colori del campionario.

! Su richiesta rivestimento sfoderabile, non disponibile per le seguenti categorie: Cat. L1, L2 e pelle cliente/C.O.L.

Pouffe in non-deformable foam polyurethane in different density and polyester fibre with wooden inside structure. Black coloured MDF base. Available covered by fabric or leather as per sample.

! On demand removable covers upon request, not available for the following categories: Cat. L1, L2 and customer leather C.O.L.



**Cm**  
100 x 80 x 38  
118 x 95 x 38

**Inches**  
39½" x 31½" x 15"  
46½" x 37½" x 15"

[For technical drawing / p.164](#)

[Pricelist 2023 / p.54](#)  
[Homescapes, sense of materials / pp.74,81](#)  
[Homescapes, gentle attitude / pp.45,48,58,61](#)

## RIVESTIMENTO/COVER



Tessuto/pelle nei colori del campionario  
Fabric/leather as per samples.

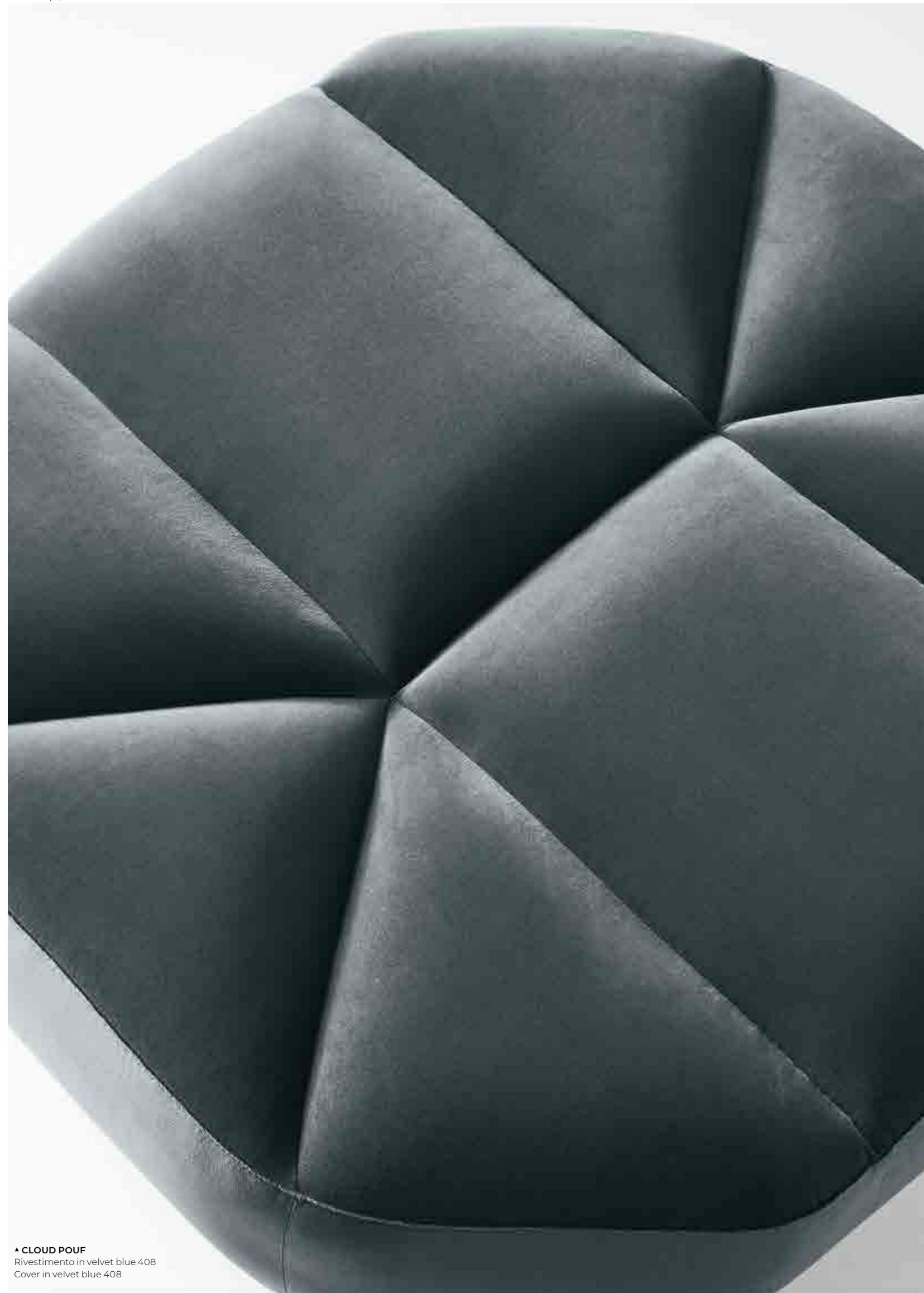

▲ **CLOUD POUF**  
 Rivestimento in velvet blue 408  
 Cover in velvet blue 408

# Cloud Pouf

Massimo Castagna / 2017

Pouf in poliuretano espanso indeformabile a densità differenziate e fibra poliestere con struttura interna in legno. Piedi in legno laccato nero. Disponibile con rivestimento in tessuto o pelle nei colori del campionario.

! Non sfoderabile.

Pouffe in non-deformable foam polyurethane in different density and polyester fibre with wooden inside structure. Black lacquered wooden feet. Available covered by fabric or leather as per sample.

! Not removable cover.



## Cm

88 x 82 x 42  
 110 x 106 x 42  
 113 x 67 x 42  
 190 x 67 x 42

## Inches

34 $\frac{3}{4}$ " x 32 $\frac{1}{2}$ " x 16 $\frac{3}{4}$ "  
 43 $\frac{1}{2}$ " x 41 $\frac{3}{4}$ " x 16 $\frac{3}{4}$ "  
 44 $\frac{1}{2}$ " x 26 $\frac{1}{2}$ " x 16 $\frac{3}{4}$ "  
 43 $\frac{1}{2}$ " x 26 $\frac{1}{2}$ " x 16 $\frac{3}{4}$ "

[For technical drawing / p.162](#)

[Pricelist 2023 / p.55](#)  
[Homescapes, intimate portraits / p.107](#)  
[Homescapes, gentle attitude / pp.24, 25, 72, 73](#)

## RIVESTIMENTO/COVER



Tessuto/pelle nei colori  
 del campionario  
 Fabric/leather as per  
 samples.

# Lilas Bench

Dainelli Studio / 2022

Panca in poliuretano espanso indeformabile a densità differenziate e fibra poliestere. Piastra di base in metallo laccato nero. Disponibile con rivestimento sfoderabile in tessuto o pelle nei colori del campionario. Tavolini in metallo laccato color fango disponibili su richiesta.

Bench in non-deformable polyurethane foam in different density and polyester fibre. Black lacquered metal base plate. Available with removable cover in fabric or leather as per samples. Fango lacquered metal side table on request.

! **Rivestimento sfoderabile.**

Per la realizzazione di elementi con rivestimento in pelle sono necessarie cuciture aggiuntive rispetto gli elementi con rivestimento in tessuto.

! **Removable cover.**

Additional stitching is required for elements with leather upholstery compared to elements with fabric upholstery.



**Cm**  
160 x 50 x 40

**Inches**  
63" x 19¾" x 15¾"

**Tavolino S**  
50 x 25 x 22

**Side table S**  
19¾" x 10" x 8¾"

**Tavolino M**  
50 x 35 x 22

**Side table M**  
19¾" x 14" x 8¾"

[For technical drawing / p.162](#)

[Pricelist 2023 / p.57](#)  
[Homescapes, intimate portraits / p.107](#)  
[Homescapes, gentle attitude / pp.52,55](#)

**RIVESTIMENTO/COVER**



Tessuto/pelle nei colori del campionario  
Fabric/leather as per samples.

**TAVOLINI/SIDE TABLES**

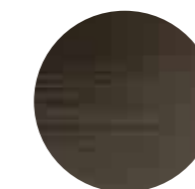

Metallo laccato color "fango"  
Metal lacquered "fango" colour

▲ **LILAS BENCH**  
Rivestimento in Velvet peacock 705  
Cover in Velvet peacock 705



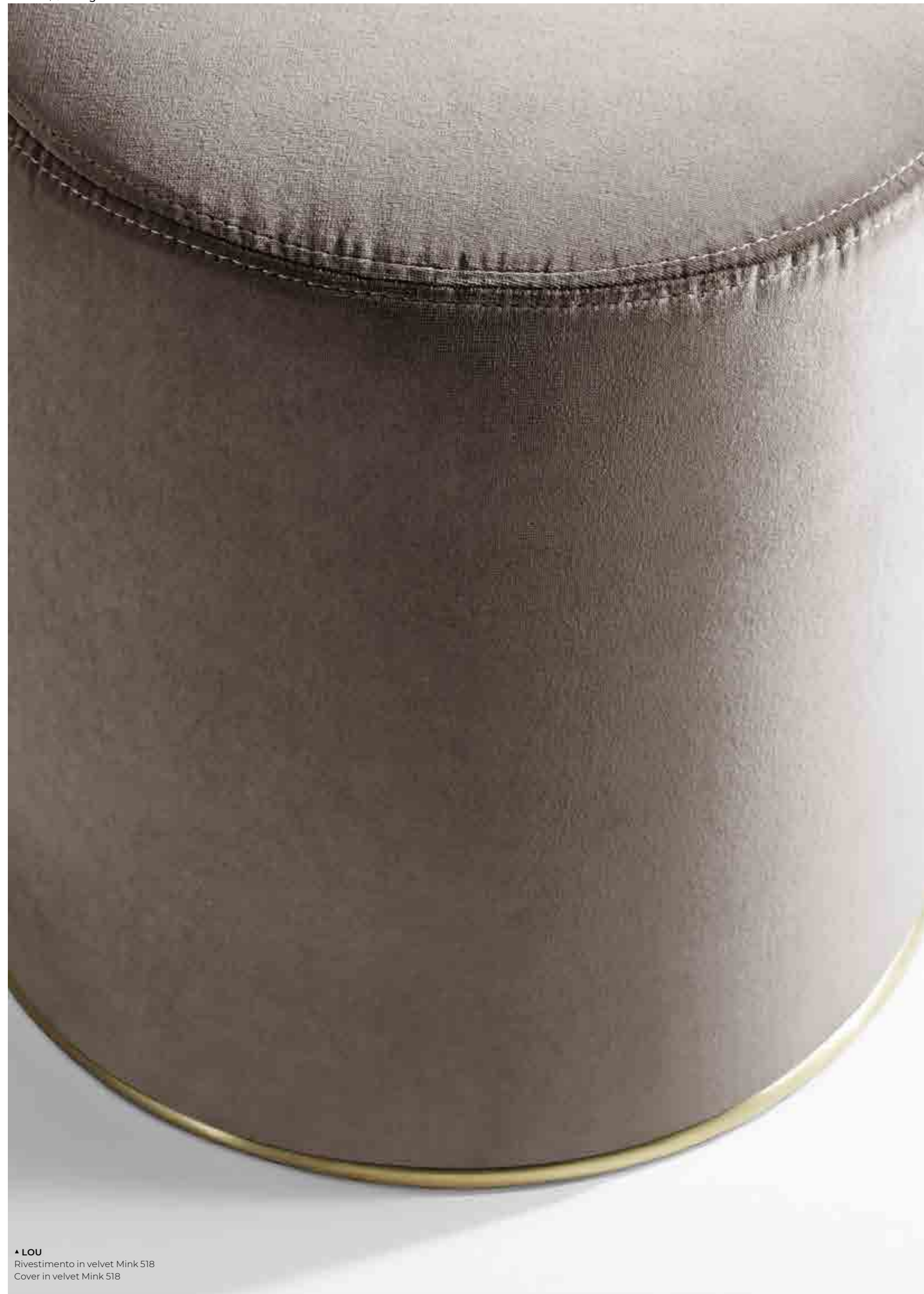

• LOU  
Rivestimento in velvet Mink 518  
Cover in velvet Mink 518

# Lou

Studio G&R / 2015

Pouf con struttura interna in legno e derivati imbottito in poliuretano espanso indeformabile a densità differenziate e fibra poliestere. Parti metalliche in ottone satinato o laccato nero opaco. Rivestimento in tessuto o pelle nei colori del campionario. Disponibile versione "loungue".

! Non sfoderabile.

Pouffe with inside structure in wood and by-products padded in non-deformable foam polyurethane in different density and polyester fibre. Metal parts in satin brass or matt black lacquered brass. Covered by fabric or leather as per samples. Also available "loungue" version.

! Not removable cover.



	Cm	Inches
S	Ø 38 x 46 Ø 38 x 41 (loungue)	Ø 15" x 18¼" Ø 15" x 16¾"
L	58 x 36 x 46 58 x 36 x 41 (loungue)	23" x 14¼" x 18¼" 23" x 14¼" x 16¾" (loungue)

For technical drawing / p.163

Pricelist 2023 / p. 58  
Homescapes, sense of materials / pp. 92, 108  
Homescapes, embracing beauty / p. 43  
Homescapes, intimate portraits / p. 50  
Homescapes, gentle attitude / pp. 15, 52, 53, 82, 83, 98, 99, 101

## RIVESTIMENTO/COVER



Tessuto/pelle nei colori del campionario  
Fabric/leather as per samples.

## PARTI METALLICHE/ METAL PARTS



Ottone satinato  
Satin brass

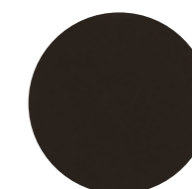

Ottone laccato nero opaco  
Matt black lacquered brass



▲ OLY

Panca struttura in metallo laccato nero antracite / Rivestimento in Aiko Anthracite 002 / Cuscino a rullo rivestito in nabuk Rose powder 2104  
Bench anthracite grey lacquered metal structure / Cover in Aiko Anthracite 002 / Rollcushion covered by nabuk Rose powder 2104

# Oly

Massimo Castagna / 2019

Panca e pouf con struttura in metallo laccato grigio antracite. Cuscino di seduta in poliuretano espanso indeformabile a densità differenziate e fibra poliestere rivestito in tessuto o pelle nei colori del campionario.  
Panca fornita con cuscino schienale a rullo nello stesso rivestimento.  
Su richiesta cuscino a rullo con rivestimento differente da definire al momento dell'ordine.

! Rivestimento sfoderabile.

Il legno massello è molto sensibile alla luce, il posizionamento vicino a sorgenti di luce naturale ne compromette la colorazione e la stabilità. Un'elevata variazione della temperatura e umidità dell'aria può provocare la comparsa di microfratture e leggere variazioni.

Bench and pouffe with anthracite grey lacquered metal structure. Seat cushion in non-deformable foam polyurethane in different density and polyester fibre covered by fabric or leather as per samples.  
Bench supplied with roll back cushion in the same covering. On request, roll back cushion in different covering to be specified when ordering.

! Removable cover.

Solid wood is very light-sensitive, placing it near natural light sources may compromise its colour and stability. Considerable differences in air temperature and humidity may cause microfractures and slight variations.



**Cm**  
**Panca**  
97 x 78 x 62  
**Pouf**  
78 x 52 x 43

**Cuscino decorativo**  
40 x 40

**Inches**  
**Bench**  
38¼" x 30¾" x 24½"  
**Pouffe**  
30¾" x 20½" x 17"

**Decorative cushion**  
15¾" x 15¾"

[For technical drawing / p.163](#)

[Pricelist 2023 / p.60](#)  
[Homescapes, sense of materials / p.102](#)  
[Homescapes, embracing beauty / p.105](#)

## STRUTTURA/STRUCTURE



Metallo laccato  
grigio antracite  
Anthracite grey  
lacquered metal

## RIVESTIMENTO/COVER



Tessuto/pelle nei colori  
del campionario  
Fabric/leather as per  
samples.



# Sensei Bench

Tollgard + Castellani / 2024

Panca con struttura in metallo e piano in legno laccato "deep black". Sul top cuscino in poliuretano espanso altezza 6cm rivestito in tessuto o in pelle nei colori del campionario. Rivestimento non sfoderabile.

Per panca 180cm disponibile versione con cuscino e piano di appoggio in cristallo 12mm molato a mezzo toro nella finitura esclusiva "Rosso Marte" oppure retroverniciato brillante nei colori del campionario. Disponibile anche in marmo 20mm Ceppo di Gré® spazzolato, Arabescato Orobico Rosso satinato, Bianco Carrara Gioia satinato oppure Dover White satinato.

Bench with "deep black" lacquered metal structure and wooden top. On the wooden top, 6cm non-deformable foam polyurethane cushion covered by fabric or leather as per samples. Not removable cover.

For the 180cm bench available version with cushion and 12mm glass top with half bull-nose grinding in the exclusive finish "Rosso Marte" or painted as per samples in the bright version. Also available with 20mm brushed Ceppo di Gré®, satin Arabescato Orobico Rosso marble, satin Bianco Carrara Gioia marble or satin Dover White marble.

! Rivestimento non sfoderabile.

! Not removable cover.



**Cm**  
137 x 45 x 39,5  
180 x 45 x 39,5

**Inches**  
54" x 17¾" x 15¾"  
71" x 17¾" x 15¾"

**Versione con cuscino e piano di appoggio**  
180 x 45 x 39,5

**Version with cushion and top**  
71" x 17¾" x 15¾"

[For technical drawing / p.163](#)

**PIANO/TOP**



**Legno laccato "deep black"**  
"deep black" lacquered wood

**RIVESTIMENTO/COVER**



**Tessuto/pelle nei colori del campionario**  
Fabric as per samples.

**STRUTTURA/STRUCTURE**



**Metallo laccato "deep black"**  
"deep black" lacquered metal

**VERSIONE/VERSION 180CM PIANO DI APPOGGIO/TOP**



**Cristallo "Rosso Marte"**  
"Rosso Marte" glass



**Cristallo brillante nei colori del campionario**  
Bright glass version as per samples

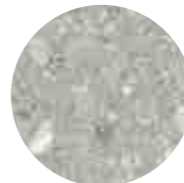

**Ceppo di Gré® spazzolato**  
Brushed Ceppo di Gré®



**Marmo Arabescato Orobico Rosso satinato**  
Arabescato Orobico Rosso satin marble



**Marmo spazzolato Bianco Carrara Gioia**  
Brushed Bianco Carrara Gioia marble

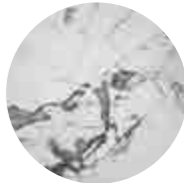

**Marmo satinato Dover White**  
Satin Dover Whitet marble

▲ SENSEI BENCH  
Struttura legno laccato "deep black" / piano di appoggio marmo Dover White / Rivestimento in Pleasure silt 116  
"Deep Black" lacquered wood structure / Dover White top / Cover Pleasure silt 116

# Stami Bench

Studiopepe / 2022

Panca con base in frassino curvato tinto nero a poro aperto e dettagli in ottone lucido. Disponibile anche versione laccata opaca nei colori: "Bianco Camargue", "Sabbia del Nilo", "Rosa Jaipur", "Rosso Persia", "Bordeaux Etruria", "Verde Provenza", "Blu Pacifico", "Grigio Londra", "Nero Giza". Cuscino in poliuretano espanso rivestito in tessuto o pelle nei colori del campionario.

Bench with curved black open pore stained ash base and bright brass details. Also available opaque lacquered wooden version in the colours "Bianco Camargue", "Sabbia del Nilo", "Rosa Jaipur", "Rosso Persia", "Bordeaux Etruria", "Verde Provenza", "Blu Pacifico", "Grigio Londra" and "Nero Giza". Cushion in polyurethane foam covered by fabric or leather as per samples.

! Rivestimento sfoderabile.

Per la realizzazione di elementi con rivestimento in pelle sono necessarie cuciture aggiuntive rispetto gli elementi con rivestimento in tessuto.

! Removable cover.

Additional stitching is required for elements with leather upholstery compared to elements with fabric upholstery.



▲ STAMI BENCH  
Struttura in frassino curvato tinto nero a poro aperto /  
Dettagli in ottone lucido / Rivestimento in Delia milk 002  
Curved black open pore stained ash base /  
Bright brass details / Cover in Delia milk 002



Cm

140 x 45 x 45  
160 x 45 x 45

Inches

55¼" x 17¾" x 17¾"  
63" x 17¾" x 17¾"

For technical drawing / p. 164

Pricelist 2023 / p. 61  
Homescapes, gentle attitude / pp. 21, 22, 24, 27, 37, 39

BASE/BASE

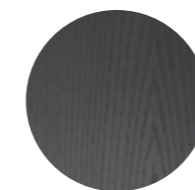

Frassino curvato tinto  
nero a poro aperto  
Curved black open pore  
stained ash



Laccato opaco  
"Bianco Camargue"  
Opaque lacquered  
"Bianco Camargue"



Laccato opaco  
"Sabbia del Nilo"  
Opaque lacquered  
"Sabbia del Nilo"

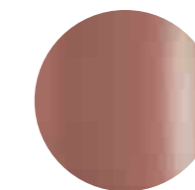

Laccato opaco  
"Rosa Jaipur"  
Opaque lacquered  
"Rosa Jaipur"

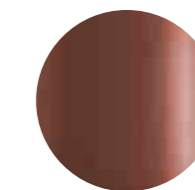

Laccato opaco  
"Rosso Persia"  
Opaque lacquered  
"Rosso Persia"

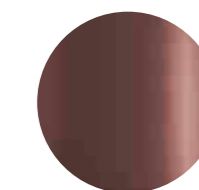

Laccato opaco  
"Bordeaux Etruria"  
Opaque lacquered  
"Bordeaux Etruria"

RIVESTIMENTO/COVER

DETTAGLI/DETAILS

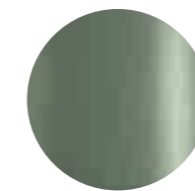

Laccato opaco  
"Verde Provenza"  
Opaque lacquered  
"Verde Provenza"

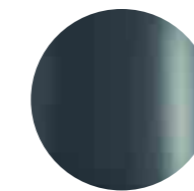

Laccato opaco  
"Blu Pacifico"  
Opaque lacquered "Blu  
Pacifico"



Laccato opaco  
"Grigio Londra"  
Opaque lacquered  
"Grigio Londra"



Laccato opaco  
"Nero Giza"  
Opaque lacquered  
"Nero Giza"



Tessuto/pelle nei colori del  
campionario  
Fabric as per samples.



Ottone lucido  
Bright brass



# Stami DayBed

Studiopepe / 2022

Day bed con base in frassino curvato tinto nero a poro aperto e dettagli in ottone lucido. Disponibile anche versione laccata opaca nei colori: "Bianco Camargue", "Sabbia del Nilo", "Rosa Jaipur", "Rosso Persia", "Bordeaux Etruria", "Verde Provenza", "Blu Pacifico", "Grigio Londra" e "Nero Giza". Cuscino in poliuretano espanso rivestito in tessuto o pelle nei colori del campionario. Il prodotto include un poggiatesta cilindrico zavorrato nello stesso rivestimento.

Day bed with curved black open pore stained ash base and bright brass details. Also available opaque lacquered wooden version in the colours "Bianco Camargue", "Sabbia del Nilo", "Rosa Jaipur", "Rosso Persia", "Bordeaux Etruria", "Verde Provenza", "Blu Pacifico", "Grigio Londra" and "Nero Giza". Cushion in polyurethane foam covered by fabric or leather as per samples. Ballasted cylindrical headrest in the same covering included.

! Rivestimento sfoderabile.

Per la realizzazione di elementi con rivestimento in pelle sono necessarie cuciture aggiuntive rispetto gli elementi con rivestimento in tessuto.

! Removable cover.

Additional stitching is required for elements with leather upholstery compared to elements with fabric upholstery.



**Cm**  
190 x 80 x 45

**Inches**  
75" x 31½" x 17¾"

[For technical drawing / p. 164](#)

[Pricelist 2023 / p. 62](#)  
[Homescapes, gentle attitude / pp. 50, 51, 92, 93](#)

## BASE/BASE

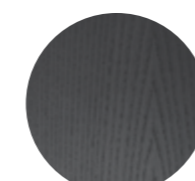

Frassino curvato tinto  
nero a poro aperto  
Curved black open pore  
stained ash



Laccato opaco  
"Bianco Camargue"  
Opaque lacquered  
"Bianco Camargue"



Laccato opaco  
"Sabbia del Nilo"  
Opaque lacquered  
"Sabbia del Nilo"

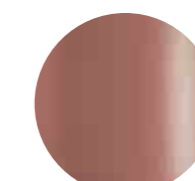

Laccato opaco  
"Rosa Jaipur"  
Opaque lacquered  
"Rosa Jaipur"

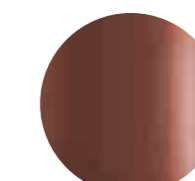

Laccato opaco  
"Rosso Persia"  
Opaque lacquered  
"Rosso Persia"



Laccato opaco  
"Bordeaux Etruria"  
Opaque lacquered  
"Bordeaux Etruria"

## RIVESTIMENTO/COVER

## DETTAGLI/DETAILS

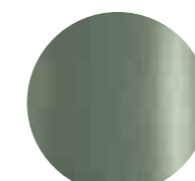

Laccato opaco  
"Verde Provenza"  
Opaque lacquered  
"Verde Provenza"

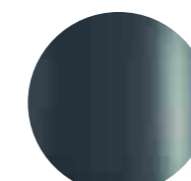

Laccato opaco  
"Blu Pacifico"  
Opaque lacquered "Blu  
Pacifico"



Laccato opaco  
"Grigio Londra"  
Opaque lacquered  
"Grigio Londra"



Laccato opaco  
"Nero Giza"  
Opaque lacquered  
"Nero Giza"



Tessuto/pelle nei colori del  
campionario  
Fabric as per samples.



Ottone lucido  
Bright brass

### ▲ STAMI BENCH

Struttura in frassino curvato tinto nero a poro aperto / Dettagli in ottone lucido / Rivestimento in Hope silver 106  
Curved black open pore stained ash base / Bright brass details / Cover in Hope silver 106

# Stami Pouf

Studiopepe / 2022



Pouf con struttura interna in legno e derivati imbottito in poliuretano espanso indeformabile a densità differenziate e fibra poliestere. Zoccolo in frassino tinto nero a poro aperto. Rivestimento in tessuto o pelle nei colori del campionario.

Pouffe with inside structure in wood and by-products padded in non-deformable foam polyurethane in different density and polyester fibre. Black open pore stained solid ash base. Covered by fabric or leather as per samples.

! Non sfoderabile.

! Not removable cover.



**Cm**  
Ø 38 x 44

**Inches**  
Ø 15" x 18½"

[For technical drawing / p.164](#)

[Pricelist 2023 / p.63](#)  
[Homescapes, gentle attitude / pp.45,54,57](#)

## RIVESTIMENTO/COVER



Tessuto/pelle nei colori del campionario  
Fabric/leather as per samples.

## BASE/BASE

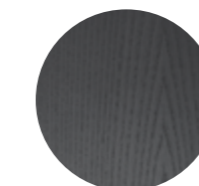

Frassino tinto nero a poro aperto  
Black stained open pore ash

▲ STAMI POUF  
Rivestimento in fard Loden green 2357  
Cover in fard Loden green 2357



▲ **TWELVE-DAY BED**  
Struttura in ottone brunito a mano / Rivestimento in leather Black 001  
Hand burnished brass structure / Cover in leather Black 001

# Twelve DayBed

Massimo Castagna / 2016

Day bed con struttura in ottone brunito a mano con materasso in poliuretano espanso rivestito in tessuto o pelle nei colori del campionario. Poggiatesta nello stesso rivestimento disponibile esclusivamente per la versione da 200 cm.

! Rivestimento sfoderabile.

## NOTE TECNICHE SUI MATERIALI

**OTTONE BRUNITO A MANO** | L'ottone brunito a mano è ottenuto da un processo di ossidazione naturale eseguito manualmente. Il risultato di questa lavorazione è un prodotto che può presentare macchie e variazioni di colore che non sono da considerarsi imperfezioni ma caratteristiche che conferiscono ad ogni pezzo una particolare unicità, rendendolo esclusivo.

Day bed with hand burnished brass structure with mattress in foam polyurethane covered by fabric or leather as per sample. Headrest in the same covering available only for cm 200 version.

! Removable cover.

Additional stitching is required for elements with leather upholstery compared to elements with fabric upholstery.

## TECHNICAL INFORMATION ON THE MATERIALS

**HAND BURNISHED BRASS** | The hand burnished brass is the consequence of hand-made process of natural oxidation. The result of this processing is a product that may show marks and colour variations. These differences are inevitable and should not be considered imperfections but distinctive features due to this craftmade processing, each product is unique and exclusive.



**Cm**  
160 x 50 x 35  
200 x 80 x 40

**Inches**  
63" x 19¾" x 14"  
78¾" x 31½" x 15¾"

[For technical drawing / p.165](#)

[Pricelist 2023 / p.64](#)  
[Homescapes, embracing beauty / pp.54,106](#)

## STRUTTURA/STRUCTURE



**Ottone brunito a mano**  
Hand burnished brass

## RIVESTIMENTO/COVER



**Tessuto/pelle nei colori del campionario**  
Fabric as per samples.

# 04

## **Panche e Pouf / Benches and Pouffe TECHNICAL MODULE**



## GENERAL INDICATION

■ tessuto/pelle consigliato  
suggested fabric/leather  
tissu/cuir conseillé  
empfohlener Stoff/Leder

□ tessuto/pelle non utilizzabile  
non-usable fabric/leather  
tissu/cuir non utilisable  
nicht verwendbarer Stoff/Leder

	CAT.A													CAT.B													CAT.C													CAT.D				CAT.LI			CAT.L2											
	Care	Chill	Cozy	Delight	Cape	Hope	Infinity	Joy	Savage	Velvet	Berlino	Daze	Della	Glee	Glow	Harmony	Maze	Meta	Mingle	Path	Perky	Perseo	Sofi	Soul	Tokyo	Touch	Twist	Vision	Armonía	Bloom	Eden	Euphoria	Fluffy	Freedom	Futura	Origine	Utopia	Wonder	Alko	Pleasure	Zest	Fard	Soft	Suede	Leather	Nabuk												
Audrey Pouf	■	■	■	■	■	■	■	■	■	■	■	■	■	■	■	■	■	■	■	■	■	■	■	■	■	■	■	■	■	■	■	■	■	■	■	■	■	■	■	■	■	■	■	■	■	■	■	■	■	■								
Cloud Pouf	■	■	■	■	■	■	■	■	■	■	■	■	■	■	■	■	■	■	■	■	■	■	■	■	■	■	■	■	■	■	■	■	■	■	■	■	■	■	■	■	■	■	■	■	■	■	■	■	■	■	■	■						
Lilas Bench	■	■	■	■	■	■	■	■	■	■	■	■	■	■	■	■	■	■	■	■	■	■	■	■	■	■	■	■	■	■	■	■	■	■	■	■	■	■	■	■	■	■	■	■	■	■	■	■	■	■	■	■	■					
Lou	■	■	■	■	■	■	■	■	■	■	■	■	■	■	■	■	■	■	■	■	■	■	■	■	■	■	■	■	■	■	■	■	■	■	■	■	■	■	■	■	■	■	■	■	■	■	■	■	■	■	■	■	■					
Oly	■	■	■	■	■	■	■	■	■	■	■	■	■	■	■	■	■	■	■	■	■	■	■	■	■	■	■	■	■	■	■	■	■	■	■	■	■	■	■	■	■	■	■	■	■	■	■	■	■	■	■	■	■	■				
Sensei Bench	■	■	■	■	■	■	■	■	■	■	■	■	■	■	■	■	■	■	■	■	■	■	■	■	■	■	■	■	■	■	■	■	■	■	■	■	■	■	■	■	■	■	■	■	■	■	■	■	■	■	■	■	■	■	■			
Stami Bench	■	■	■	■	■	■	■	■	■	■	■	■	■	■	■	■	■	■	■	■	■	■	■	■	■	■	■	■	■	■	■	■	■	■	■	■	■	■	■	■	■	■	■	■	■	■	■	■	■	■	■	■	■	■	■			
Stami Daybed	■	■	■	■	■	■	■	■	■	■	■	■	■	■	■	■	■	■	■	■	■	■	■	■	■	■	■	■	■	■	■	■	■	■	■	■	■	■	■	■	■	■	■	■	■	■	■	■	■	■	■	■	■	■	■			
Stami Pouf	■	■	■	■	■	■	■	■	■	■	■	■	■	■	■	■	■	■	■	■	■	■	■	■	■	■	■	■	■	■	■	■	■	■	■	■	■	■	■	■	■	■	■	■	■	■	■	■	■	■	■	■	■	■	■	■		
Twelve Daybed	■	■	■	■	■	■	■	■	■	■	■	■	■	■	■	■	■	■	■	■	■	■	■	■	■	■	■	■	■	■	■	■	■	■	■	■	■	■	■	■	■	■	■	■	■	■	■	■	■	■	■	■	■	■	■	■	■	■

Cuscini decorativi  
Decorative cushions

Ø38  
Ø15"

Cuscino decorativo in fibra poliestere e chiusura con cerniera.

Decorative polyester fibre cushion with zip closure.

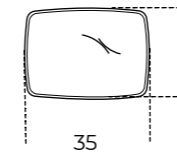

35 x 25  
14" x 10"

Cuscino decorativo in fibra poliestere rifinito con bordo perimetrale e chiusura con cerniera.

Decorative polyester fibre cushion finished with perimetral trim and zip closure.

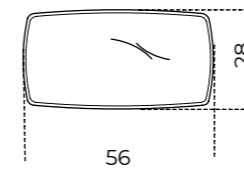

56 x 28  
22 3/4" x 11 1/4"

Cuscino decorativo in fibra poliestere rifinito con bordo perimetrale e chiusura con cerniera.

Decorative polyester fibre cushion finished with perimetral trim and zip closure.

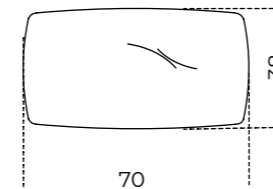

70 x 38  
27 3/4" x 15"

Cuscino decorativo in fibra poliestere e chiusura con cerniera.

Decorative polyester fibre cushion with zip closure.

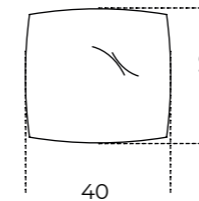

40 x 40  
15 3/4" x 15 3/4"

Cuscino decorativo in fibra poliestere e chiusura con cerniera.

Decorative polyester fibre cushion with zip closure.

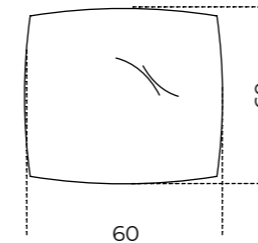

60 x 60  
23 3/4" x 23 3/4"

Cuscino decorativo in fibra poliestere e chiusura con cerniera.

Decorative polyester fibre cushion with zip closure.

\*cuciture per versione in pelle

\*stitching for leather covers

! Gallotti&Radice declina ogni responsabilità rispetto le prestazioni tecniche ed estetiche dei prodotti realizzati con tessuti/pelli non consigliate.

! Gallotti & Radice declines all responsibility for the technical and aesthetical performances of products made with non-recommended fabrics / leathers.

Gallotti&Radice declina ogni responsabilità rispetto alle prestazioni tecniche ed estetiche dei prodotti rivestiti con C.O.L. e C.O.M.

Gallotti & Radice declines all responsibility for technical and aesthetic performance of products covered with C.O.L. and C.O.M.

Per informazioni di dettaglio relative alla composizione, proprietà e lavaggio/manutenzione dei rivestimenti si rinvia al "Volume 4 | Materiali".

For detailed information on the composition, properties and maintenance of the upholstery, please refer to the "Volume 4 | Materials".

È possibile rivestire tutti i prodotti della collezione Gallotti&Radice con con tessuto/pelle cliente, previa approvazione di un campione. Gallotti&Radice non è responsabile per quanto riguarda il risultato formale, la durata del tessuto e la costanza dei colori (vedi: "Volume 4 | Materiali").

Furniture may be upholstered with customers' own fabrics after approval of a sample. Gallotti&Radice is not responsible for the aesthetic result, durability of the fabric and the uniformity of the colours (see: Volume 4 | Materials).

L'approvazione del tessuto fornito dal Cliente da parte di Gallotti&Radice si limita solamente alla realizzazione della tappezzeria.

The approval by Gallotti&Radice of the C.O.L. and C.O.M is limited only to the upholstery. Gallotti&Radice therefore declines all responsibility for resistance to use, any resistance to fire or other technical characteristics of the fabrics supplied by the customer.

Gallotti&Radice declina pertanto ogni responsabilità in merito alla resistenza all'uso, alla eventuale resistenza al fuoco o ad altre caratteristiche tecniche dei tessuti forniti dal Cliente.

Gallotti & Radice is not responsible for the materials sent by the customer, for any defects and technical deficiencies of the same, for possible defective reactions to the upholstered product as well as for the instructions regarding maintenance and washing.

Gallotti&Radice non è responsabile dei materiali inviati dal cliente, di eventuali difetti e carenze tecniche degli stessi, delle possibili reazioni difettose a prodotto tappezzato nonché delle istruzioni riguardanti manutenzione e lavaggio.

**Audrey Pouf** | Massimo Castagna, 2019

Product information / p. 138

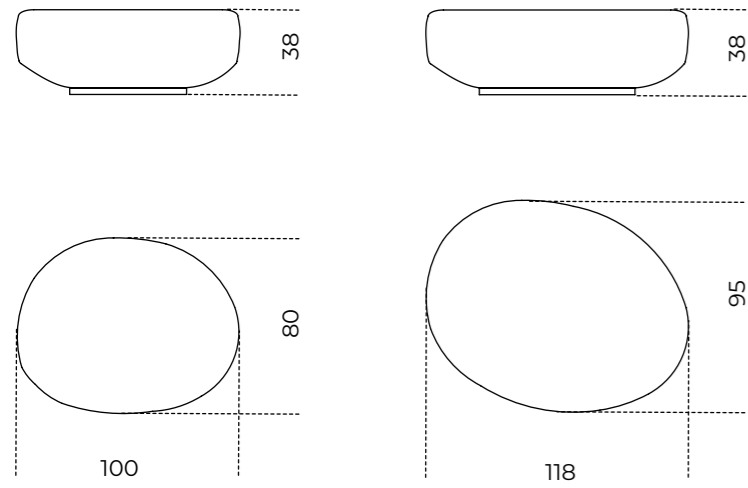

**Lou** | Studio G&R, 2015

Product information / p. 144

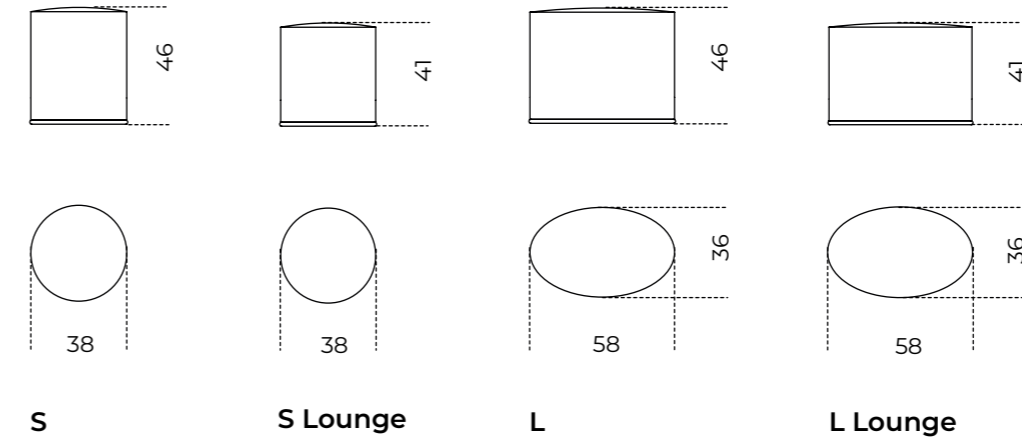

**Cloud Pouf** | Massimo Castagna, 2017

Product information / p. 140

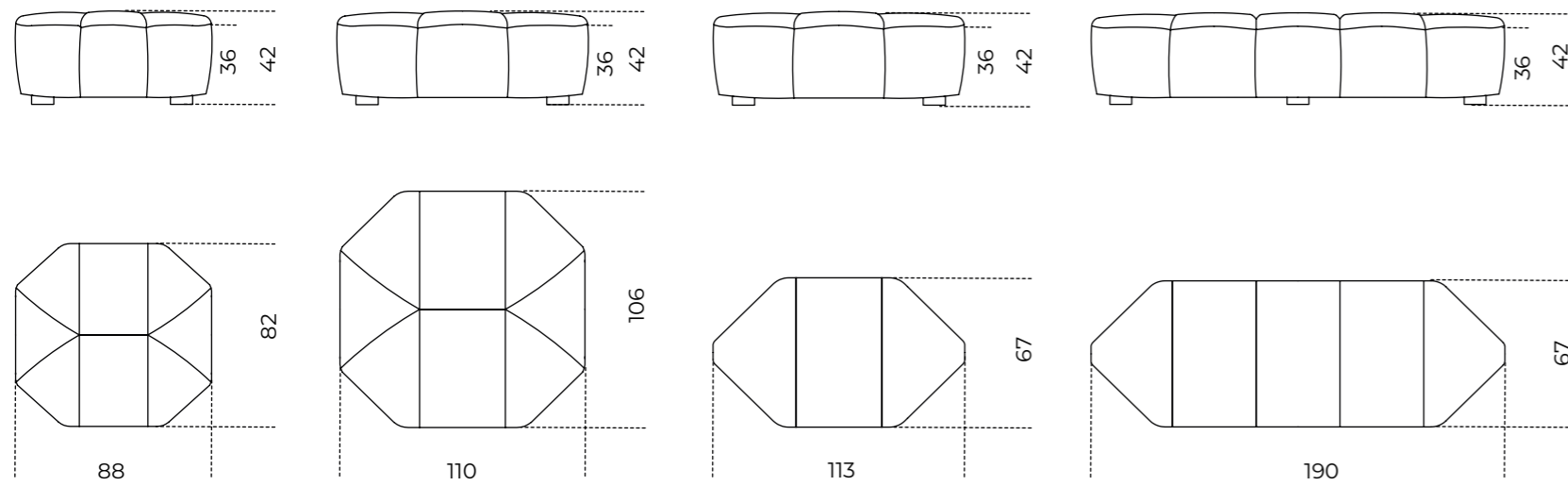

**Oly** | Massimo Castagna, 2019

Product information / p. 146

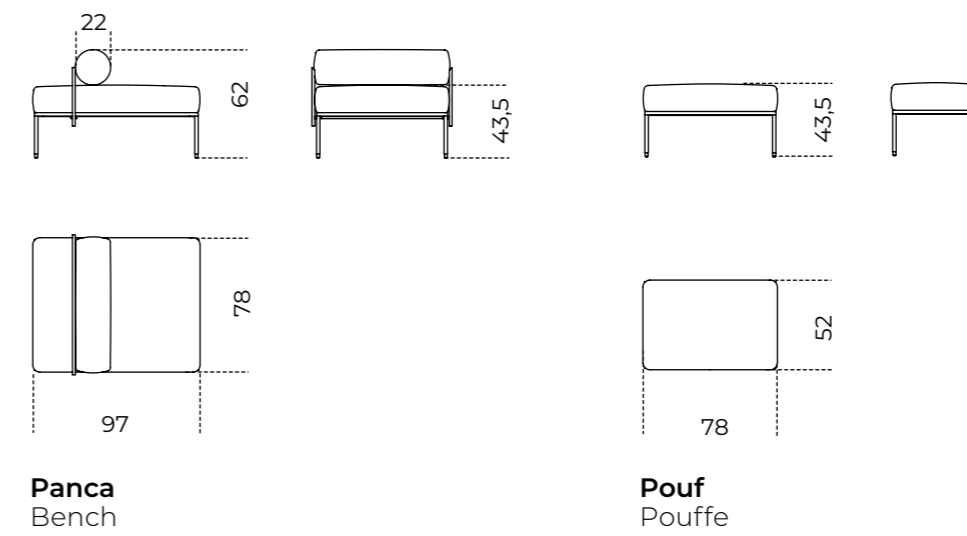

**Lilas Bench** | Dainelli Studio, 2022

Product information / p. 142

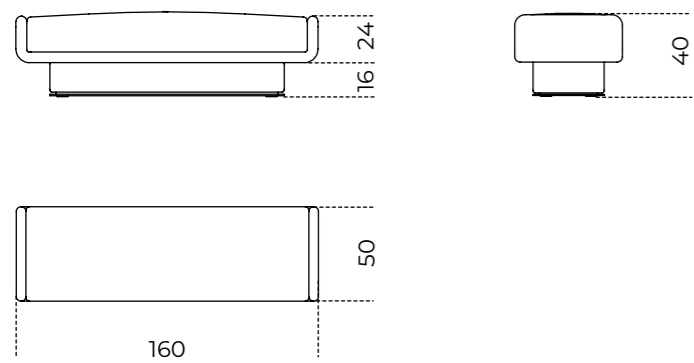

Posizione cuciture per versione in pelle/pelle scamosciata  
Stitching position for leather/suede version

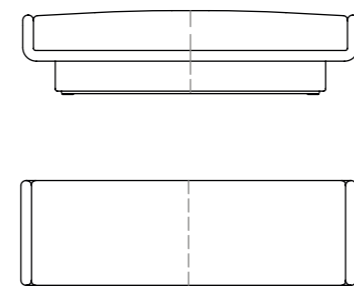

**Tavolino S (50 x 25 x 22h)**  
Side table S (19 3/4" x 10" x 8 3/4"h)



**Tavolino M (50 x 35 x 22h)**  
Side table M (19 3/4" x 14" x 8 3/4"h)

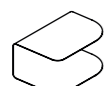

**Sensei Bench** | Tollgard + Castellani, 2024

Product information / p. 148

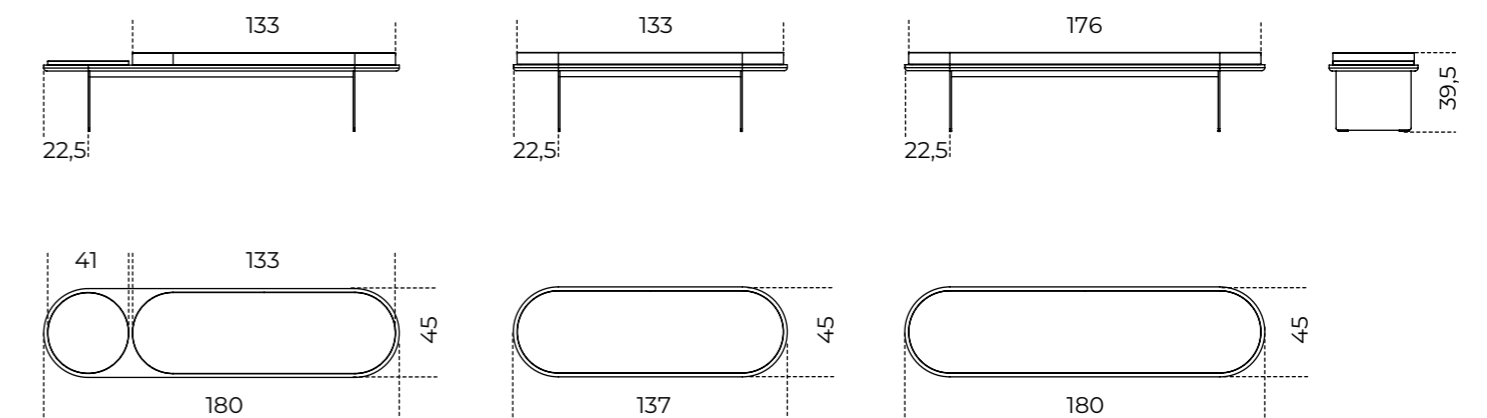

**Stami Bench** | Studiopepe, 2022

[Product information / p. 150](#)

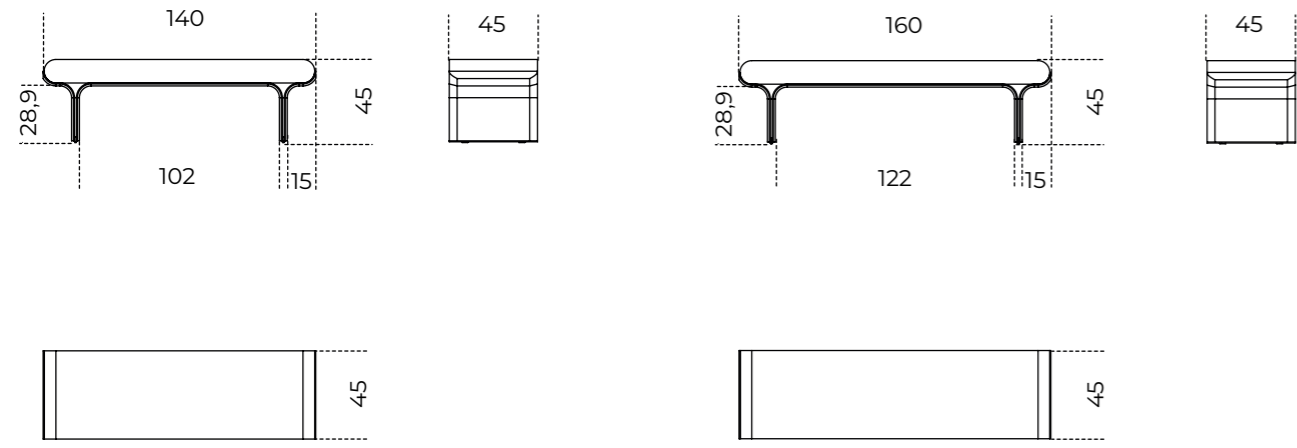

**Twelve Daybed** | Massimo Castagna, 2016

[Product information / p. 156](#)

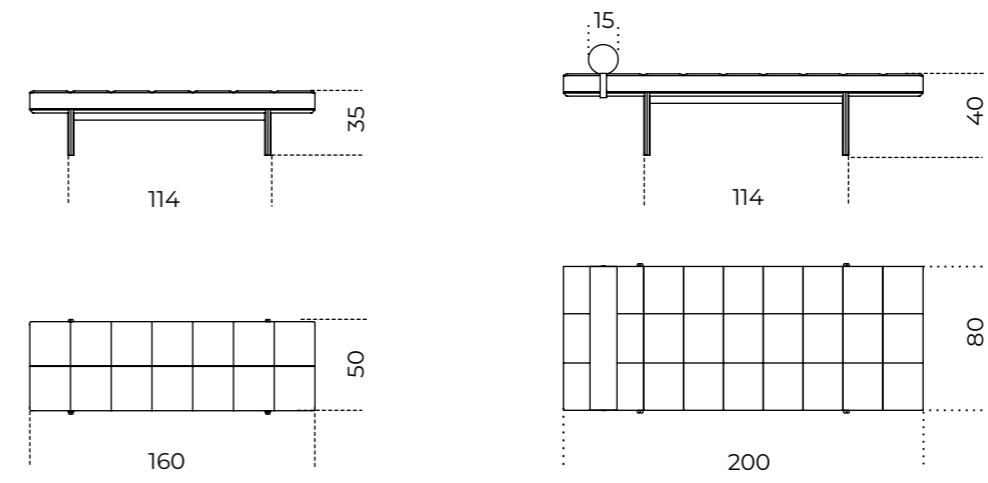

**Stami Daybed** | Studiopepe, 2022

[Product information / p. 152](#)

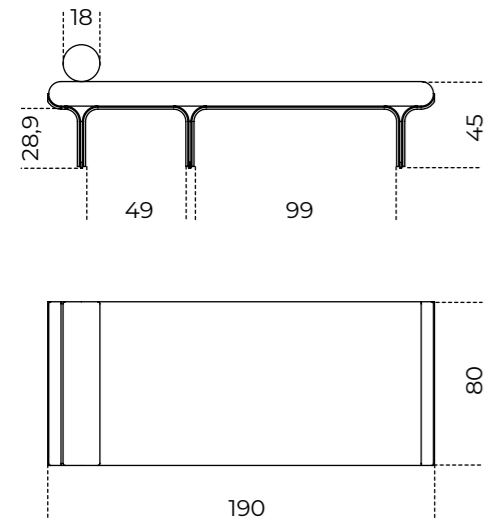

**Stami Pouf** | Studiopepe, 2022

[Product information / p. 154](#)

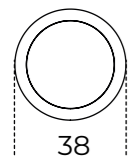
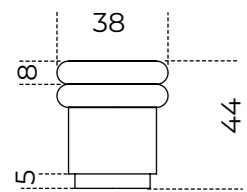

## **05** Divani e poltrone /

Sofas and armchairs

<u>168</u>	<b>0417</b>
<u>170</u>	<b>Akiko Lounge</b>
<u>172</u>	<b>Audrey</b>
<u>174</u>	<b>Audrey Motion</b>
<u>176</u>	<b>Audrey Poltrona</b>
<u>178</u>	<b>Cloud</b>
<u>180</u>	<b>Cloud Chiase Longue</b>
<u>182</u>	<b>Cloud Infinity</b>
<u>184</u>	<b>Cloud Poltrona</b>
<u>186</u>	<b>Elissa</b>
<u>188</u>	<b>Elissa Sectional</b>
<u>192</u>	<b>Fiona</b>
<u>194</u>	<b>Fiona Soft</b>
<u>196</u>	<b>First</b>
<u>198</u>	<b>First Modulare</b>
<u>200</u>	<b>First Poltrona &amp; Pouf</b>
<u>202</u>	<b>Lilas</b>
<u>204</u>	<b>Lilas Mosaïque</b>
<u>206</u>	<b>Livre</b>
<u>208</u>	<b>Sophie</b>
<u>210</u>	<b>Sophie Sofa</b>
<u>212</u>	<b>Stami Lounge</b>
<u>214</u>	<b>Stami Loveseat</b>
<u>216</u>	<b>Stami Sofa</b>
<u>218</u>	<b>Stami Sofa Plus</b>
<u>222</u>	<b>Informazioni tecniche/ Technical informations</b>



▲ 0417  
Struttura in massello di frassino curvato tinto nero a poro aperto / Rivestimento in velvet Ochre 1688  
Black lacquered open pore solid curved ash structure / Cover in velvet Ochre 1688

# 0417

Studio G&R / 2017

Poltroncina con struttura in massello di frassino curvato tinto nero a poro aperto. Disponibile anche in frassino naturale, tinto tabacco a poro aperto, tinto "Pure" bianco a poro aperto o tinto grigio smoke a poro aperto. Seduta e schienale, in multistrato curvato con imbottitura in poliuretano espanso, rivestiti in tessuto o pelle nei colori del campionario.

! Non sfoderabile.

Il massello di frassino naturale presenta variazioni di colore che vanno dal biondo chiaro al rosa fino ad arrivare al bruno pallido, con eventuali sfumature di verde. Queste differenze sono da considerarsi caratteristiche di questa essenza.

Il legno massello è molto sensibile alla luce, il posizionamento vicino a sorgenti di luce naturale ne compromette la colorazione e la stabilità. Un'elevata variazione della temperatura e umidità dell'aria può provocare la comparsa di microfrazioni e leggere variazioni.

Armchair with black open pore stained solid curved ash structure. Also available in natural ash, tobacco stained open pore, "Pure" white stained open pore or grey smoke stained open pore ash. Curved plywood seat and backrest with polyurethane foam padding covered by fabric or leather as per sample.

! Not removable cover.

Natural ash solid wood has colour variations ranging from light blonde to pink to pale brown, with possible shades of green. These differences are to be considered characteristic of this essence.

Solid wood is very light-sensitive, placing it near natural light sources may compromise its colour and stability. Considerable differences in air temperature and humidity may cause microfractures and slight variations.



Cm  
70 x 64 x 64

Inches  
27¾" x 25¼" x 25¼"

For technical drawing / p. 226

Pricelist 2023 / p. 71  
Homescapes, gentle attitude / pp. 21, 22, 24, 25

## STRUTTURA/STRUCTURE

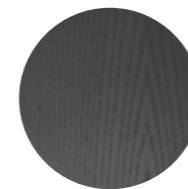

Frassino tinto  
nero a poro aperto  
Black stained  
open pore ash



Frassino tinto  
grigio smoke a poro aperto  
Grey smoke open pore  
stained ash



Frassino tinto tabacco a  
poro aperto  
Tobacco stained  
open pore ash



Frassino naturale  
Natural ash



Frassino tinto "Pure"  
bianco a poro aperto  
"Pure" white open pore  
stained ash



Tessuto/pelle nei colori  
del campionario  
Fabric/leather as per  
samples.

## RIVESTIMENTO/COVER

# Akiko Lounge

Oscar e Gabriele Buratti / 2017

Poltrona con struttura interna in metallo imbottita con schiuma poliuretanic a densità differenziate e fibra poliestere. Basamento in metallo verniciato color "warm grey".  
Fornita di un cuscino cm 60x60 in piuma rivestito nello stesso rivestimento.  
Rivestimento sfoderabile in tessuto o pelle nei colori del campionario.  
Disponibile versione con movimento girevole a 180° con ritorno con basamento a 4 razze in metallo verniciato color "warm grey" con finalini.

Armchair with metal inside structure padded with polyurethane foam in different density and polyester fibre. Metal base lacquered in the "warm grey" colour. A cm 60x60 downpadding cushion covered in the same finish of the armchair included.  
Removable cover in fabric or leather as per samples.  
Also available version with 180° swivel movement with return with "warm grey" colour lacquered four star metal base with feet.

## ! Rivestimento sfoderabile

Per la realizzazione di elementi con rivestimento in pelle sono necessarie cuciture aggiuntive rispetto gli elementi con rivestimento in tessuto.

## ! Removable cover

Additional stitching is required for elements with leather upholstery compared to elements with fabric upholstery.



**Cm**  
78,5 x 83,5 x 70

**Inches**  
31¼" x 33" x 27¾"

[For technical drawing / p. 226](#)

[Pricelist 2023 / p. 72](#)  
[Homescapes, gentle attitude / pp. 45, 48, 72, 74](#)

## BASE METALLICA/ METAL BASE



Metallo verniciato  
"warm grey"  
Metal lacquered  
"warm grey" colour

## RIVESTIMENTO/COVER



Tessuto/pelle nei colori  
del campionario  
Fabric/leather as per  
samples.

• AKIKO LOUNGE  
Rivestimento in Futura milk 002  
Cover in Futura milk 002



• **AUDREY**  
 Rivestimento in velvet Ochre 1688  
 Cover in velvet Ochre 1688

# Audrey

Massimo Castagna / 2017

Divano in poliuretano espanso indeformabile a densità differenziate e fibra poliestere con struttura interna in legno e derivati. Basamento in MDF in massa nero. Disponibile con rivestimento in tessuto o pelle nei colori del campionario. Fornito di due cuscini schienale in fibra poliestere. Su richiesta rivestimento sfoderabile, non disponibile per le seguenti categorie: Cat. L1, L2 e pelle cliente/C.O.L.

! Su richiesta rivestimento sfoderabile escluso in Cat. L1, L2 e pelle cliente/C.O.L.

Per la realizzazione di elementi con rivestimento in pelle sono necessarie cuciture aggiuntive rispetto gli elementi con rivestimento in tessuto.

Disponibile versione destra o sinistra.  
 La scelta della versione destra o sinistra è da specificare al momento dell'ordine.

Sofa in non-deformable polyurethane foam in different density and polyester fibre with inside structure in wood and by-products. Black coloured MDF base. Available covered by fabric or leather as per sample. Supplied with two backrest cushions in polyester fibre. Removable covers upon request, not available for the following categories: Cat. L1, L2 and customer leather C.O.L.

! On demand removable cover excluding in Cat. L1, L2 and client supplied leather.

Additional stitching is required for elements with leather upholstery compared to elements with fabric upholstery.

Available right or left version.  
 The right or left version has to be confirmed when ordering.



## Cm

207 x 109 x 73  
 252 x 116 x 73  
 278 x 123 x 73  
 326 x 137 x 73

## Cuscino schienale (incluso):

45 x 6 x 41 (Audrey 207)  
 67 x 6 x 41 (Audrey 252)  
 71 x 6 x 41 (Audrey 278)  
 83 x 6 x 41 (Audrey 326)

## Cuscino decorativo

40 x 40  
 60 x 60

## Inches

81½" x 43" x 28¾"  
 99¼" x 45¾" x 28¾"  
 109½" x 48½" x 28¾"  
 128½" x 54" x 28¾"

## Backrest cushion (included):

17¾" x 2½" x 16¼" (Audrey 207)  
 26½" x 2½" x 16¼" (Audrey 252)  
 28" x 2½" x 16¼" (Audrey 278)  
 32¾" x 2½" x 16¼" (Audrey 326)

## Decorative cushion

15¾" x 15¾"  
 23¾" x 23¾"

[For technical drawing / p. 227](#)

[Pricelist 2023 / p. 73](#)  
[Homescapes, sense of materials / p. 8](#)  
[Homescapes, intimate portraits / p. 65](#)  
[Homescapes, gentle attitude / pp. 92, 93](#)

## RIVESTIMENTO/COVER



Tessuto/pelle nei colori del campionario  
 Fabric/leather as per samples.



▲ **AUDREY MOTION**  
Modulo terminale (T160) cm 160 x 140 x 73h / Rivestimento in Sauvage moss 015  
Terminal modules (T160) inches 63" x 55½" x 28¾" h / Cover in Sauvage moss 015

# Audrey Motion

Massimo Castagna / 2020

Divano modulare in poliuretano espanso indeformabile a densità differenziate e fibra poliestere con struttura interna in legno e derivati. Basamento in MDF in massa nero. Disponibile con rivestimento in tessuto o pelle nei colori del campionario. Rivestimento sfoderabile, non disponibile per le seguenti categorie: Cat. L1, L2 e pelle cliente/C.O.L. Fornito di cuscini schienale in fibra poliestere.

! Rivestimento sfoderabile escluso in Cat. L1, L2 e pelle cliente/C.O.L.

Per la realizzazione di elementi con rivestimento in pelle sono necessarie cuciture aggiuntive rispetto gli elementi con rivestimento in tessuto

I divani componibili sono dotati di un pratico sistema di aggancio che garantisce il fissaggio dei moduli.

Moduli non vendibili singolarmente.

Modular sofa made of non-deformable differentiated density polyurethane foam and polyester fiber with internal structure made of wood and wood derivatives. Base in MDF in black mass. Available with fabric or leather upholstery in sample colors. Removable cover, not available for the following categories: Cat. L1, L2 and customer/C.O.L. leather. Supplied with polyester fiber back cushions.

! Removable cover excluding in Cat. L1, L2 and client supplied leather.

Additional stitching is required for elements with leather upholstery compared to elements with fabric upholstery.

The modular sofas are supplied with a coupling system that guarantees the fixing of the modules.

Modules cannot be sold individually.



	<b>Cm</b>	<b>Inches</b>
	<b>Moduli terminali:</b>	<b>Terminal modules:</b>
<b>T115 L/R</b>	115 x 113 x 73	45½" x 44½" x 28¾"
<b>T160 L/R</b>	160 x 140 x 73	63" x 55½" x 28¾"
	<b>Moduli centrali:</b>	<b>Central modules:</b>
<b>C175</b>	175 x 107 x 73	69" x 42¼" x 28¾"
<b>C200</b>	200 x 105 x 73	78¾" x 41½" x 28¾"
<b>C235</b>	235 x 113 x 73	92¾" x 44½" x 28¾"
	<b>Cuscino schienale (incluso):</b>	<b>Backrest cushion (included):</b>
	65 x 6 x 40	25¾" x 2½" x 15¾"
	<b>Cuscino decorativo</b>	<b>Decorative cushion</b>
	40 x 40	15¾" x 15¾"
	60 x 60	23¾" x 23¾"

[For technical drawing / p.228-229](#)

[Pricelist 2023 / p.75](#)  
[Homescapes, embracing beauty / p.82](#)

## RIVESTIMENTO/COVER



Tessuto/pelle nei colori del campionario  
Fabric/leather as per samples.



# Audrey Poltrona

Massimo Castagna / 2018

Poltrona girevole (360°) in poliuretano espanso indeformabile a densità differenziate e fibra poliestere con struttura interna legno. Fornita di un cuscino schienale in fibra poliestere. Basamento in MDF in massa nero. Disponibile con rivestimento in tessuto o pelle nei colori del campionario. Su richiesta rivestimento sfoderabile, non disponibile per le seguenti categorie: Cat. L1, L2 e pelle cliente/C.O.L.

! Su richiesta rivestimento sfoderabile escluso in Cat. L1, L2 e pelle cliente/C.O.L.

Per la realizzazione di elementi con rivestimento in pelle sono necessarie cuciture aggiuntive rispetto gli elementi con rivestimento in tessuto. Disponibile versione destra o sinistra.

La scelta della versione destra o sinistra è da specificare al momento dell'ordine.

Swivel armchair (360°) made of non-deformable differentiated density polyurethane foam and polyester fiber with wooden inner frame. Supplied with a polyester fiber back cushion. Base made of MDF in black mass. Available with fabric or leather upholstery in sample colors. Removable cover upon request, not available for the following categories: Cat. L1, L2 and customer/C.O.L. leather..

! On demand removable cover excluding in Cat. L1, L2 and client supplied leather.

Additional stitching is required for elements with leather upholstery compared to elements with fabric upholstery.

Available right or left version.  
The right or left version has to be confirmed when ordering.



## Cm

102 x 84 x 68  
122 x 97 x 68

**Cuscino schienale (incluso):**  
50 x 6 x 40

**Cuscino decorativo**  
40 x 40

## Inches

40<sup>1</sup>/<sub>4</sub>" x 33<sup>3</sup>/<sub>4</sub>" x 27"  
48<sup>1</sup>/<sub>4</sub>" x 38<sup>1</sup>/<sub>4</sub>" x 27"

**Backrest cushion (included):**  
19<sup>3</sup>/<sub>4</sub>" x 2<sup>1</sup>/<sub>2</sub>" x 15<sup>3</sup>/<sub>4</sub>"

**Decorative cushion**  
15<sup>3</sup>/<sub>4</sub>" x 15<sup>3</sup>/<sub>4</sub>"

[For technical drawing / p. 230](#)

[Pricelist 2023 / p. 79](#)  
[Homescapes, sense of materials / p. 10](#)  
[Homescapes, embracing beauty / p. 82](#)

## RIVESTIMENTO/COVER



Tessuto/pelle nei colori del campionario  
Fabric/leather as per samples.



# Cloud

Massimo Castagna / 2016

Divano in poliuretano espanso indeformabile a densità differenziate e fibra poliestere con struttura interna in legno. Piedi in legno laccato nero. Disponibile con rivestimento in tessuto o pelle nei colori del campionario.

Sofa in non-deformable foam polyurethane in different density and polyester fibre with wooden inside structure. Black lacquered wooden feet. Available covered by fabric or leather as per samples.

! Non sfoderabile.

! Not removable cover



#### Cm

140 x 100 x 75  
220 x 100 x 75  
260 x 100 x 75

#### Inches

55¼" x 39½" x 29¾"  
86¾" x 39½" x 29¾"  
102½" x 39½" x 29¾"

#### Cuscino decorativo

40 x 40  
60 x 60

#### Cuscino decorativo

15¾" x 15¾"  
23¾" x 23¾"

[For technical drawing / p. 230](#)

[Pricelist 2023 / p. 80](#)  
[Homescapes, intimate portraits / p. 106](#)  
[Homescapes, gentle attitude / pp. 72, 74](#)

#### RIVESTIMENTO/COVER



Tessuto/pelle nei colori del campionario  
Fabric/leather as per samples.

# Cloud Chaise Longue

Massimo Castagna / 2024

Poltrona chaise longue in poliuretano espanso indeformabile a densità differenziate e fibra poliestere con struttura interna in legno. Piedi in legno laccato nero. Disponibile con rivestimento in tessuto o pelle nei colori del campionario.

Chaise-longue armchair in non-deformable foam polyurethane in different density and polyester fibre with wooden inside structure. Black lacquered wooden feet. Available covered by fabric or leather as per sample.

! Non sfoderabile.

! Not removable cover



**Cm**  
160 x 165 x 75

**Inches**  
63" x 65" x 29¾"

[For technical drawing / p. 230](#)

[Pricelist 2023 / p. 80](#)  
[Homescapes, intimate portraits / p. 106](#)  
[Homescapes, gentle attitude / pp. 72, 74](#)

RIVESTIMENTO/COVER

PIEDINI/FEET



Tessuto/pelle nei colori del campionario  
Fabric/leather as per samples.

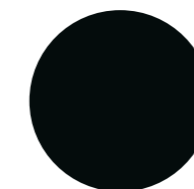

Legno laccato nero  
Black lacquered wood



▲ **CLOUD INFINITY**  
 Rivestimento in Touch milk 111  
 Cover in Touch milk 111

# Cloud Infinity

Massimo Castagna / 2022

Divano modulare in poliuretano espanso indeformabile a densità differenziate e fibra poliestere con struttura interna in legno. Piedi in legno laccato nero. Disponibile con rivestimento in tessuto o pelle nei colori del campionario. Non sfoderabile.  
 Tavolino in legno laccato color fango disponibile su richiesta.  
 Disponibile anche con top in marmo Travertino Romano spazzolato naturale (non resinato), Calacatta Vagli Oro lucido naturale o Emperador Brown spazzolato.

! Non sfoderabile.  
 Su richiesta rivestimento sfoderabile, non disponibile per le seguenti categorie: Cat. L1, L2 e pelle cliente/C.O.L.

Moduli non vendibili singolarmente.

Modular sofa made of non-deformable differentiated density polyurethane foam and polyester fiber with internal wooden frame. Black lacquered wooden feet. Available with fabric or leather upholstery in sample colors. Not removable cover.  
 Mud-colored lacquered wood coffee table available on request.  
 Also available with natural brushed Travertino Romano marble top (not resinated), natural polished Calacatta Vagli Oro or brushed Emperador Brown.

! Not removable cover.  
 On demand removable cover upon request, not available for the following categories: Cat. L1, L2 and customer/C.O.L. leather.

Modules cannot be sold individually.



<b>Cm</b>	<b>Inches</b>
<b>Moduli terminali:</b>	<b>Terminal modules:</b>
<b>T1 L/R</b> 76 x 100 x 75	30" x 39½" x 29¾"
<b>T2 L/R</b> 114 x 100 x 75	45" x 39½" x 29¾"
<b>T3 L/R</b> 170 x 100 x 75	60" x 39½" x 29¾"
<b>Moduli centrali:</b>	<b>Central modules:</b>
<b>C2</b> 76 x 100 x 75	30" x 39½" x 29¾"
<b>C3</b> 114 x 100 x 75	45" x 39½" x 29¾"
<b>TCL</b> 152 x 165 x 75	60" x 65" x 29¾"
<b>Moduli angolari:</b>	<b>Corner modules:</b>
<b>TA L/R</b> 170 x 124 x 75	67" x 49" x 29¾"
<b>CA</b> 140 x 124 x 75	55¼" x 49" x 29¾"
<b>CA90</b> 150 x 150 x 75	59¼" x 59¼" x 29¾"
<b>Tavolino:</b>	<b>Side table:</b>
100 x 40 x 35	39½" x 15¾" x 14
<b>Cuscino decorativo</b>	<b>Decorative cushion</b>
40 x 40	15¾" x 15¾"
60 x 60	23¾" x 23¾"

[For technical drawing / p. 231-235](#)

[Pricelist 2023 / p. 81](#)  
[Homescapes, gentle attitude / pp. 21, 24, 25, 72, 73, 76, 78](#)

RIVESTIMENTO/COVER



Tessuto/pelle nei colori del campionario  
 Fabric/leather as per samples.

PIEDINI/FEET

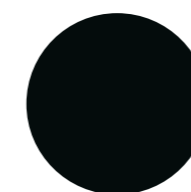

Legno laccato nero  
 Black lacquered wood

TAVOLINO/SIDE TABLE  
 BASE / BASE

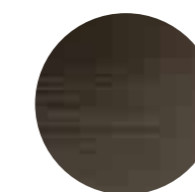

Legno laccato color "fango"  
 Wooden lacquered "fango" colour

TAVOLINO/SIDE TABLE  
 TOP



Travertino Romano  
 spazzolato naturale  
 Natural brushed  
 Travertino Romano



Marmo lucido naturale  
 Calacatta Vagli Oro  
 Natural polished  
 Calacatta Vagli Oro marble



Marmo spazzolato  
 Emperador Brown  
 Brushed Emperador  
 Brown marble



# Cloud Poltrona

Massimo Castagna / 2016

Poltrona in poliuretano espanso indeformabile a densità differenziate e fibra poliestere con struttura interna in legno. Piedi in legno laccato nero. Disponibile con rivestimento in tessuto o pelle nei colori del campionario.

! Non sfoderabile.

Armchair in non-deformable foam polyurethane in different density and polyester fibre with wooden inside structure. Black lacquered wooden feet. Available covered by fabric or leather as per sample.

! Not removable cover.



**Cm**  
110 x 100 x 75

**Cuscino decorativo**  
40 x 40  
60 x 60

**Inches**  
43½" x 39½" x 29¾"

**Decorative cushion**  
15¾" x 15¾"  
23¾" x 23¾"

[For technical drawing / p.236](#)

[Pricelist 2023 / p.87](#)  
[Homescapes, gentle attitude / p.21](#)

## RIVESTIMENTO/COVER



Tessuto/pelle nei colori del campionario  
Fabric/leather as per samples.

# Elissa

Dainelli Studio / 2020

Divano con struttura interna in legno e derivati. Imbottito con poliuretano espanso indeformabile a densità differenziate e fibra poliestere. Cucitura orizzontale perimetrale esterna. Cuscini schienale in piuma inclusi. Basamento in legno laccato color "fango". Disponibile con rivestimento in tessuto o pelle nei colori del campionario.

Sofa with inside structure in wood and by-products. Padded with non-deformable foam polyurethane in different densities and polyester fibre. Horizontal stitching along the external perimeter. Downpadding backrest cushions included. Wooden base lacquered in the "fango" colour. Available covered by fabric or leather as per samples.

! Rivestimento sfoderabile.

Per la realizzazione di elementi con rivestimento in pelle sono necessarie cuciture aggiuntive rispetto gli elementi con rivestimento in tessuto.

! Removable cover.

Additional stitching is required for elements with leather upholstery compared to elements with fabric upholstery.



**Cm**

240 x 96 x 69  
280 x 96 x 69

**Inches**

94½" x 38" x 27¼"  
110¼" x 38" x 27¼"

**Cuscino schienale (incluso):**  
60 x 60

**Backrest cushion (included):**  
23¾" x 23¾"

**Cuscino decorativo**  
40 x 40  
60 x 60

**Decorative cushion**  
15¾" x 15¾"  
23¾" x 23¾"

[For technical drawing / p.236](#)

[Pricelist 2023 / p.88](#)  
[Homescapes, embracing beauty / p.25](#)  
[Homescapes, gentle attitude / pp.37,39](#)

**BASE/BASE**

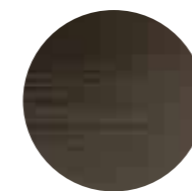

**Legno laccato color "fango"**  
Wooden lacquered "fango"  
colour

**RIVESTIMENTO/COVER**



**Tessuto/pelle nei colori del campionario**  
Fabric/leather as per samples.

▲ ELISSA  
Rivestimento in delia milk 002 / Base in legno laccato color "fango"  
Cover in delia milk 002 / Wooden lacquered "fango" colour base

# Elissa Sectional

Dainelli Studio / 2021

Divano modulare con struttura interna in legno e derivati. Imbottito con poliuretano espanso indeformabile a densità differenziate e fibra poliestere. Cucitura orizzontale perimetrale esterna. Cuscini schienale in piuma inclusi. Basamento in legno laccato color "fango". Disponibile con rivestimento in tessuto o pelle nei colori del campionario.

Modular sofa with internal structure made of wood and wood derivatives. Padded with non-deformable differentiated density polyurethane foam and polyester fiber. External horizontal perimeter stitching. Feather back cushions included. Lacquered wood base in "mud" color. Available with fabric or leather upholstery in sample colors.

## ! Rivestimento sfoderabile.

Per la realizzazione di elementi con rivestimento in pelle sono necessarie cuciture aggiuntive rispetto gli elementi con rivestimento in tessuto.

I divani componibili sono dotati di un pratico sistema di aggancio che garantisce il fissaggio dei moduli.

Moduli non vendibili singolarmente.

## ! Removable cover.

Additional stitching is required for elements with leather upholstery compared to elements with fabric upholstery.

The modular sofas are supplied with a coupling system that guarantees the fixing of the modules.

Modules cannot be sold individually.



	<b>Cm</b>	<b>Inches</b>
	<b>Moduli terminali:</b>	<b>Terminal modules:</b>
ELS-T120L/R	120 x 96 x 69	47¼" x 38" x 27¼"
ELS-T140L/R	140 x 96 x 69	55¼" x 38" x 27¼"
ELS-T200L/R	220 x 96 x 69	86¾" x 38" x 27¼"
ELS-T260L/R	260 x 96 x 69	120½" x 38" x 27¼"
	<b>Moduli centrali:</b>	<b>Central modules:</b>
ELS-C100	100 x 90 x 69	39½" x 35½" x 27¼"
ELS-C120	120 x 90 x 69	47¼" x 35½" x 27¼"
ELS-C200	200 x 90 x 69	78¾" x 35½" x 27¼"
ELS-C240	240 x 90 x 69	94½" x 35½" x 27¼"
	<b>Moduli angolari:</b>	<b>Corner modules:</b>
ELS-TA225L/R	225 x 147 x 69	88¾" x 58" x 27¼"
ELS-TA240L/R	240 x 120 x 69	94½" x 47¼" x 27¼"
ELS-TA280L/R	280 x 120 x 69	110¼" x 47¼" x 27¼"
ELS-CA200	200 x 147 x 69	78¾" x 58" x 27¼"
ELS-A140L/R	140 x 120 x 69	55¼" x 47¼" x 27¼"
	<b>Cuscino schienale (incluso):</b>	<b>Backrest cushion (included):</b>
	60 x 60	23¾" x 23¾"
	<b>Cuscino decorativo</b>	<b>Decorative cushion</b>
	40 x 40	15¾" x 15¾"
	60 x 60	23¾" x 23¾"

[For technical drawing / p. 237-242](#)

[Pricelist 2023 / p. 89](#)  
[Homescapes, intimate portraits / pp. 17, 24](#)

## BASE/BASE

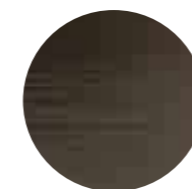

Legno laccato color "fango"  
Wooden lacquered "fango"  
colour

## RIVESTIMENTO/COVER



Tessuto/pelle nei colori  
del campionario  
Fabric/leather as per  
samples.

▲ ELISSA SECTIONAL  
Rivestimento in joy grey 007 / Base in legno laccato color "fango"  
Cover in joy grey 007 / Wooden lacquered "fango" colour base

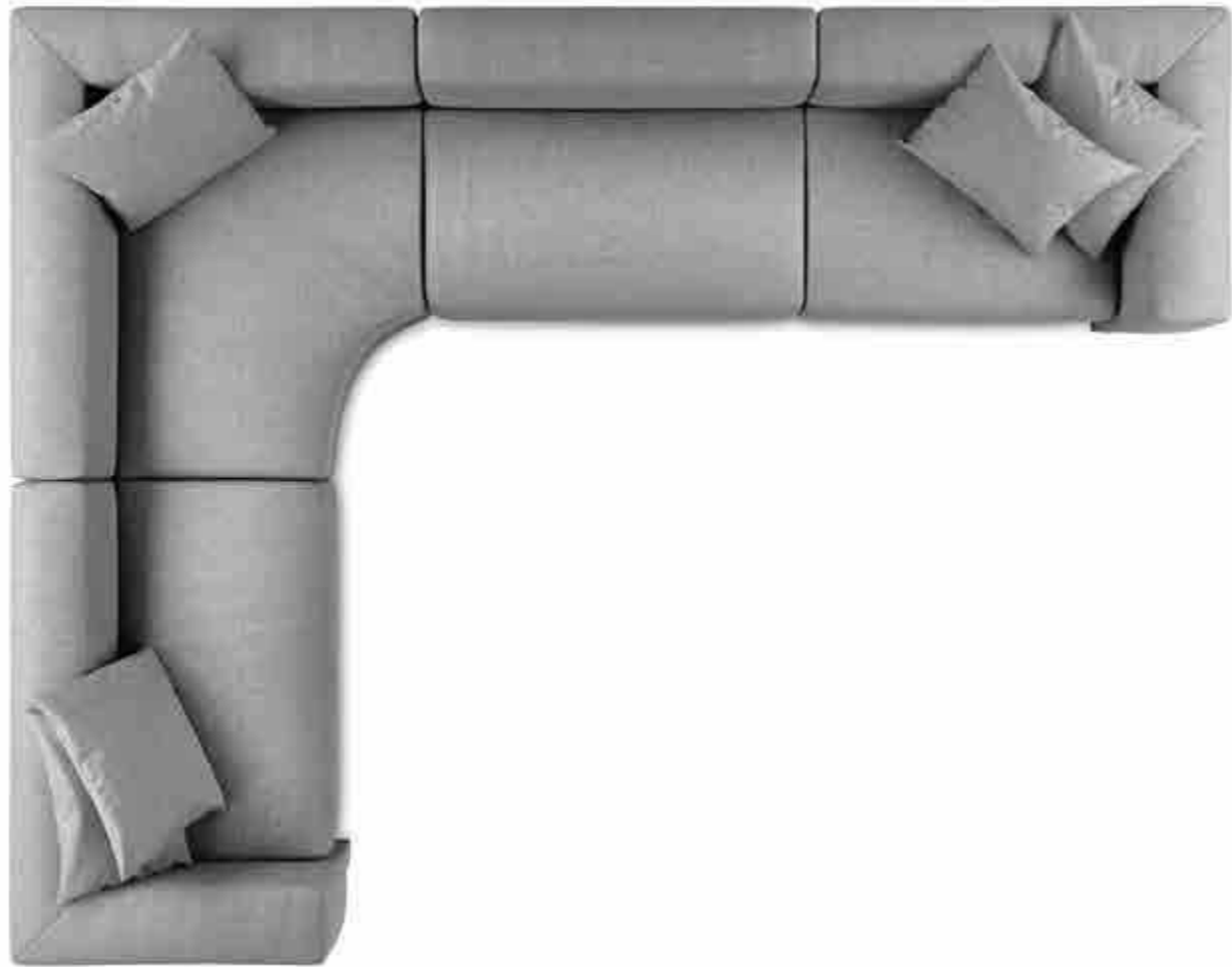

COMPOSITION 3



COMPOSITION 6

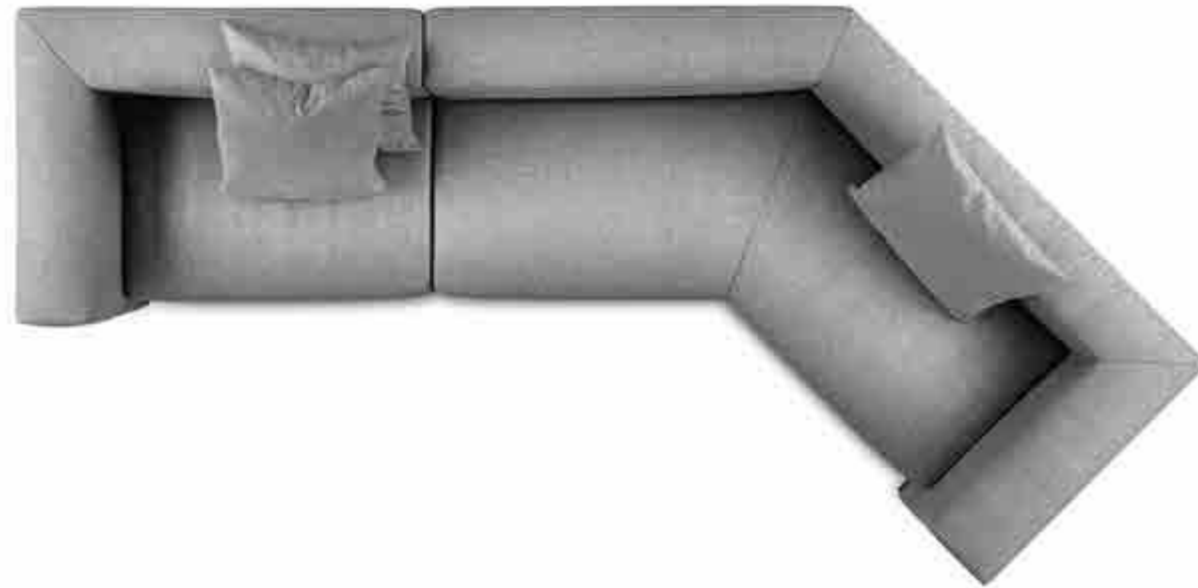

COMPOSITION 4

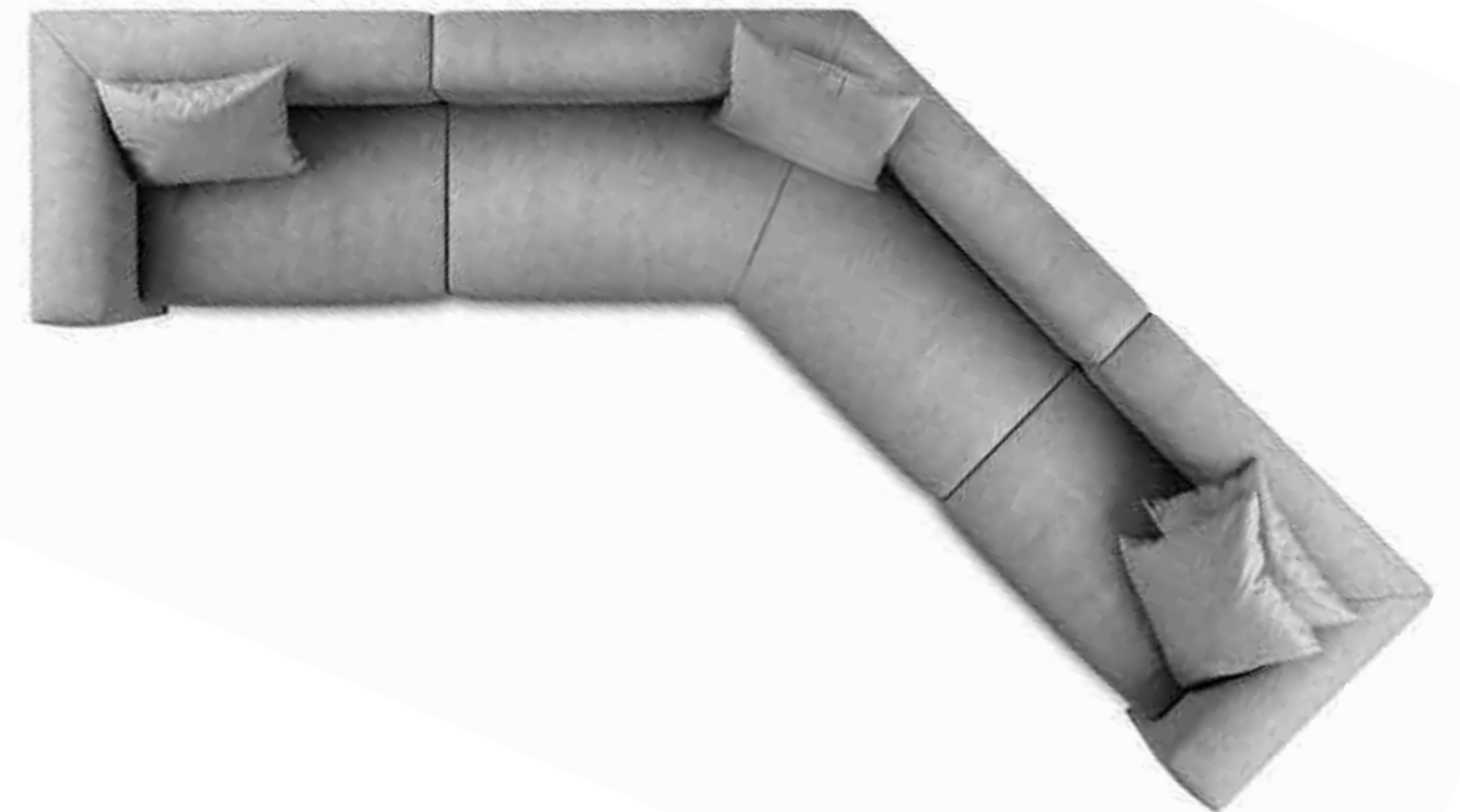

COMPOSITION 5





▲ **FIONA**  
Modulo divano (modulo BL) cm 170 x 100 x 71h / Rivestimento in velvet mink 518  
Modular sofa (BL module) inches 67" x 39½" x 28"h / Cover in velvet mink 518

# Fiona

Massimo Castagna / 2018

Divano modulare in poliuretano espanso indeformabile a densità differenziate e fibra poliestere con struttura interna in legno. Appoggio a terra su piedini in materiale termoplastico. Schienale lavorato in capitonné. Cuscini schienale misto piuma. Disponibile con rivestimento in tessuto o pelle nei colori del campionario.

! Non sfoderabile.

Per la realizzazione di elementi con rivestimento in pelle sono necessarie cuciture aggiuntive rispetto gli elementi con rivestimento in tessuto.

I divani componibili sono dotati di un pratico sistema di aggancio che garantisce il fissaggio dei moduli.

Moduli non vendibili singolarmente.

Modular sofa made of non-deformable differentiated density polyurethane foam and polyester fiber with internal wooden frame. Floor support on thermoplastic feet. Capitonné worked backrest. Back cushions mixed with feather. Available with fabric or leather upholstery in sample colors.

! Not removable cover.

Additional stitching is required for elements with leather upholstery compared to elements with fabric upholstery.

The modular sofas are supplied with a coupling system that guarantees the fixing of the modules.

Modules cannot be sold individually.

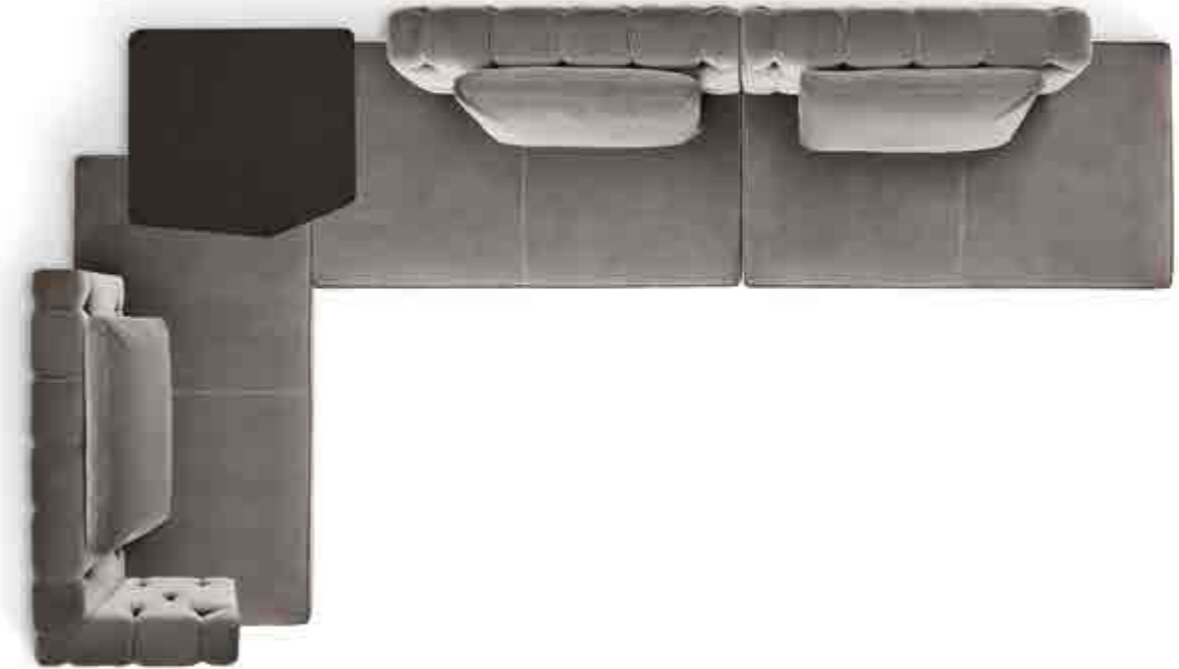

	Cm Moduli	Inches Modules
A-130 L/R	130 x 110 x 71	51¼" x 43½" x 28"
A-180 L/R	180 x 110 x 71	71" x 43½" x 28"
A-230 L/R	230 x 110 x 71	90¾" x 43½" x 28"
B-180 L/R	180 x 110 x 71	71" x 43½" x 28"
B-230 L/R	230 x 110 x 71	90¾" x 43½" x 28"
C-180L/R	180 x 110 x 71	71" x 43½" x 28"
C-230L/R	230 x 110 x 71	90¾" x 43½" x 28"
D-130	130 x 110 x 71	51¼" x 43½" x 28"
D-180	180 x 110 x 71	71" x 43½" x 28"
D-230	230 x 110 x 71	90¾" x 43½" x 28"
E-180 L/R	180 x 110 x 71	71" x 43½" x 28"
F-110 L/R	110 x 180 x 71	43½" x 71" x 28"
G-110	110 x 180 x 71	43½" x 71" x 28"

**Cuscino schienale (incluso):** 83 x 6 x 47  
**Backrest cushion (included):** 32¾" x 2½" 18¾"

**Cuscino decorativo**  
40 x 40  
60 x 60

**Decorative cushion**  
15¾" x 15¾"  
23¾" x 23¾"

[For technical drawing / p.242](#)

[Pricelist 2023 / p.96](#)

## RIVESTIMENTO/COVER



Tessuto/pelle nei colori del campionario  
Fabric/leather as per samples.

# Fiona Soft

Massimo Castagna / 2019

Divano modulare in poliuretano espanso indeformabile a densità differenziate e fibra poliestere con struttura interna in legno. Appoggio a terra su piedini in materiale termoplastico. Schienale con cuciture lineari verticali. Cuscini schienale misto piuma. Disponibile con rivestimento in tessuto o pelle nei colori del campionario.

Modular sofa made of non-deformable differentiated density polyurethane foam and polyester fiber with internal wooden frame. Floor support on thermoplastic feet. Backrest with vertical linear seams. Back cushions mixed with feather. Available with fabric or leather upholstery in sample colors.

## ! Non sfoderabile.

Per la realizzazione di elementi con rivestimento in pelle sono necessarie cuciture aggiuntive rispetto gli elementi con rivestimento in tessuto.

I divani componibili sono dotati di un pratico sistema di aggancio che garantisce il fissaggio dei moduli.

Moduli non vendibili singolarmente.

## ! Not removable cover.

Additional stitching is required for elements with leather upholstery compared to elements with fabric upholstery.

The modular sofas are supplied with a coupling system that guarantees the fixing of the modules.

Modules cannot be sold individually.



	Cm Moduli	Inches Modules
A-130 L/R	130 x 110 x 71	51¼" x 43½" x 28"
A-180 L/R	180 x 110 x 71	71" x 43½" x 28"
A-230 L/R	230 x 110 x 71	90¾" x 43½" x 28"
B-180 L/R	180 x 110 x 71	71" x 43½" x 28"
B-230 L/R	230 x 110 x 71	90¾" x 43½" x 28"
C-180L/R	180 x 110 x 71	71" x 43½" x 28"
C-230L/R	230 x 110 x 71	90¾" x 43½" x 28"
D-130	130 x 110 x 71	51¼" x 43½" x 28"
D-180	180 x 110 x 71	71" x 43½" x 28"
D-230	230 x 110 x 71	90¾" x 43½" x 28"
E-180 L/R	180 x 110 x 71	71" x 43½" x 28"
F-110 L/R	110 x 180 x 71	43½" x 71" x 28"
G-110	110 x 180 x 71	43½" x 71" x 28"

<b>Cuscino schienale (incluso)</b> 83 x 6 x 47	<b>Backrest cushion (included)</b> 32¾" x 2½" 18¾"
<b>Cuscino decorativo</b> 40 x 40 60 x 60	<b>Decorative cushion</b> 15¾" x 15¾" 23¾" x 23¾"

For technical drawing / p. 243

Pricelist 2023 / p. 100  
Homescapes, sense of materials / p. 88

## RIVESTIMENTO/COVER



Tessuto/pelle nei colori del campionario  
Fabric/leather as per samples.

▲ FIONA SOFT  
Modulo divano (modulo AL) cm 170 x 100 x 71h / Rivestimento in nabuk rose powder 2104  
Modular sofa (AL module) inches 67" x 39½" x 28"h / Cover in nabuk rose powder 2104



▲ **FIRST**  
Rivestimento in velvet Peacock 705  
Cover in velvet Peacock 705

# First

Massimo Castagna / 2014

Divano in poliuretano espanso indeformabile a densità differenziate e fibra poliestere con struttura interna in legno. Piedi in legno laccato nero. Disponibile con rivestimento in tessuto o pelle nei colori del campionario.

! Non sfoderabile.

Per la realizzazione di elementi con rivestimento in pelle sono necessarie cuciture aggiuntive rispetto gli elementi con rivestimento in tessuto.

Sofa in non-deformable foam polyurethane in different density and polyester fibre with wooden inside structure. Black lacquered wooden feet. Available covered by fabric or leather as per sample.

! Not removable cover.

Additional stitching is required for elements with leather upholstery compared to elements with fabric upholstery.



**Cm**  
172 x 80 x 68

**Cuscino decorativo**  
35 x 25  
56 x 28  
40 x 40

**Inches**  
67<sup>3</sup>/<sub>4</sub>" x 31<sup>1</sup>/<sub>2</sub>" x 27"

**Decorative cushion**  
14" x 10"  
22<sup>1</sup>/<sub>4</sub>" x 11<sup>1</sup>/<sub>4</sub>"  
15<sup>3</sup>/<sub>4</sub>" x 15<sup>3</sup>/<sub>4</sub>"

[For technical drawing / p.244](#)

[Pricelist 2023 / p.104](#)

## RIVESTIMENTO/COVER



Tessuto/pelle nei colori  
del campionario  
Fabric/leather as per  
samples.

# First Modulare

Massimo Castagna / 2015

Divano modulare in poliuretano espanso indeformabile a densità differenziate e fibra poliestere e piuma con struttura interna in legno. Piedi in legno laccato nero. Cuscini schienale misto piuma. Disponibile con rivestimento in tessuto o pelle nei colori del campionario.

Modular sofa made of non-deformable differentiated density polyurethane foam and polyester fiber and feather with internal wooden frame. Black lacquered wooden feet. Back cushions mixed feather. Available with fabric or leather upholstery in sample colors.

## ! Non sfoderabile.

Per la realizzazione di elementi con rivestimento in pelle sono necessarie cuciture aggiuntive rispetto gli elementi con rivestimento in tessuto.

I divani componibili sono dotati di un pratico sistema di aggancio che garantisce il fissaggio dei moduli.

Moduli non vendibili singolarmente.

## ! Not removable cover.

Additional stitching is required for elements with leather upholstery compared to elements with fabric upholstery.

The modular sofas are supplied with a coupling system that guarantees the fixing of the modules.

Modules cannot be sold individually.



## Cm

107 x 98 x 68  
167 x 98 x 68  
207 x 98 x 68

## Cuscino schienale (incluso):

73 x 40 (First modulare 107)  
63 x 40 (First modulare 167)  
73 x 40 (First modulare 207)

## Cuscino decorativo

35 x 25  
56 x 28  
40 x 40

## Inches

42¼" x 38¾" x 27"  
65¾" x 38¾" x 27"  
81½" x 38¾" x 27"

## Backrest cushion (included):

28¾" x 15¾" (First modulare 107)  
25" x 15¾" (First modulare 167)  
28¾" x 15¾" (First modulare 207)

## Decorative cushion

14" x 10"  
22¼" x 11¼"  
15¾" x 15¾"

[For technical drawing / p.244](#)

[Pricelist 2023 / p.105](#)

## RIVESTIMENTO/COVER



Tessuto/pelle nei colori del campionario  
Fabric/leather as per samples.

▲ **FIRST MODULARE**  
Rivestimento in velvet Mink 518  
Cover in velvet Mink 518



▲ FIRST POLTRONA&POUF  
 Rivestimento in velvet Moss 7307  
 Cover in velvet Moss 7307

# First Poltrona & Pouf

Massimo Castagna / 2015

Poltrona e pouf in poliuretano espanso indeformabile a densità differenziate e fibra poliestere con struttura interna in legno. Piedi in legno laccato nero. Disponibile con rivestimento in tessuto o pelle nei colori del campionario.

Armchair and ottoman made of non-deformable differentiated density polyurethane foam and polyester fiber with internal wooden frame. Black lacquered wooden feet. Available with fabric or leather upholstery in sample colors.

! Non sfoderabile.

Per la realizzazione di elementi con rivestimento in pelle sono necessarie cuciture aggiuntive rispetto gli elementi con rivestimento in tessuto.

! Not removable cover.

Additional stitching is required for elements with leather upholstery compared to elements with fabric upholstery.



**Cm**  
**Poltrona**  
 87 x 80 x 68  
**Pouf**  
 78 x 50 x 38

**Inches**  
**Armchair**  
 34½" x 31½" x 27"  
**Pouffe**  
 30¾" x 19¾" x 15"

**Cuscino decorativo**  
 35 x 25

**Decorative cushion**  
 14" x 10"

[For technical drawing / p. 244](#)

[Pricelist 2023 / p. 107](#)  
[Homescapes, intimate portraits / pp. 89, 97](#)  
[Homescapes, gentle attitude / p. 90](#)

## RIVESTIMENTO/COVER



Tessuto/pelle nei colori del campionario  
 Fabric/leather as per samples.



▲ LILAS  
Rivestimento in Hope Rose powder 005  
Cover in Hope Rose powder 005

# Lilas

Dainelli Studio / 2021

Poltrona con struttura interna in legno e derivati, imbottita con poliuretano espanso indeformabile e fibra poliestere. Cuscino schienale e seduta imbottiti con poliuretano espanso indeformabile a densità differenziate e fibra poliestere. Disponibile in versione fissa o con movimento girevole a 180° con ritorno da specificare al momento dell'ordine. Disponibile con rivestimento in tessuto o pelle nei colori del campionario.

! Rivestimento sfoderabile.

Per la realizzazione di elementi con rivestimento in pelle sono necessarie cuciture aggiuntive rispetto gli elementi con rivestimento in tessuto.

Armchair with internal frame made of wood and wood derivatives, padded with stress-resistant polyurethane foam and polyester fiber. Back and seat cushion padded with non-deformable polyurethane foam in differentiated densities and polyester fiber. Available in fixed or 180° swivel movement with return to be specified when ordering. Available with fabric or leather upholstery in colors from sample book.

! Removable cover.

Additional stitching is required for elements with leather upholstery compared to elements with fabric upholstery.



**Cm**  
70 x 70 x 72

**Inches**  
27¾" x 27¾" x 28½"

[For technical drawing / p. 245](#)

[Pricelist 2023 / p. 108](#)  
[Homescapes, intimate portraits / pp. 18, 24](#)  
[Homescapes, gentle attitude / pp. 37, 39](#)

## RIVESTIMENTO/COVER



Tessuto/pelle nei colori del campionario  
Fabric/leather as per samples.

# Lilas Mosaique

Dainelli Studio / 2022

Sistema di sedute componibili in poliuretano espanso indeformabile a densità differenziate e fibra poliestere. Piastra di base in metallo laccato nero. Disponibile con rivestimento sfoderabile in tessuto o pelle nei colori del campionario. Schienali zavorrati disponibili su richiesta. Gli schienali sono liberamente posizionabili e possono essere accompagnati da un cuscino 55x55 cm per rendere più confortevole la seduta. Tavolini in metallo laccato color fango disponibili su richiesta.

Modular seating system in non-deformable polyurethane foam in different density and polyester fibre. Black lacquered metal base plate. Available with removable cover in fabric or leather as per samples. Ballasted backrest available on request. The backrests can be positioned as preferred and can be accompanied by 55x55cm cushion to make the seat more comfortable. Fango lacquered metal side table on request.

! Per la realizzazione di elementi con rivestimento in pelle sono necessarie cuciture aggiuntive rispetto gli elementi con rivestimento in tessuto.

! Additional stitching is required for elements with leather upholstery compared to elements with fabric upholstery.



	Cm Moduli	Inches Modules	Schienale	Backrest
LM-95X95	95 x 95 x 40	37½" x 37½" x 15¾"	80 x 26 x 30	31½" x 10¼" x 12
LM-R-95X95	95 x 95 x 40	37½" x 37½" x 15¾"		
LM-143X143	143 x 143 x 40	56½" x 56½" x 15¾"	Cuscino schienale (incluso) 55 x 8 x 55	Backrest cushion (included) 31¾" x 3¼" x 21¾"
LM-R-143X143	143 x 143 x 40	56½" x 56½" x 15¾"	Cuscino decorativo 40 x 40	Decorative cushion 15¾" x 15¾"
LM-HR-143X100	143 x 100 x 40	56½" x 39½" x 15¾"	Tavolino S 50 x 25 x 22	Side table S 19¾" x 10" x 8¾"
LM-190X95	190 x 95 x 40	75" x 37½" x 15¾"	Tavolino M 50 x 35 x 22	Side table M 19¾" x 14" x 8¾"
LM-275X95	275 x 95 x 40	108½" x 37½" x 15¾"		

For technical drawing / p. 245-246

Pricelist 2023 / p. 109  
Homescapes, gentle attitude / pp. 41, 43, 103

## RIVESTIMENTO/COVER



Tessuto/pelle nei colori del campionario  
Fabric/leather as per samples.

## PIASTRA DI BASE/ BASE PLATE

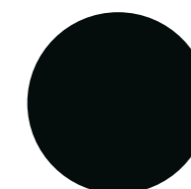

Legno laccato nero  
Black lacquered wood

## TAVOLINI/ SIDE TABLES

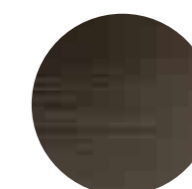

Metallo laccato color "fango"  
Metal lacquered "fango" colour

• LILAS MOSAÏQUE  
Rivestimento in Velvet peacock 705 / Tavolini in metallo laccato color "fango"  
Cover in Velvet peacock 705 / Side table in metal lacquered "fango" colour



▲ LIVRE  
Rivestimento in Joy Rose powder 008  
Cover in Joy Rose powder 008

# Livre

Federica Biasi / 2020

Poltrona con struttura interna in legno e derivati e parti metalliche. Imbottita con poliuretano espanso indeformabile a densità differenziate e fibra poliestere. Basamento in massello di frassino tinto nero a poro aperto. Disponibile anche versione con movimento girevole a 360° con ritorno e basamento in acciaio verniciato nero rivestito in massello di frassino tinto nero a poro aperto, da specificare al momento dell'ordine. Rivestimento in tessuto o pelle nei colori del campionario.

! Rivestimento sfoderabile.

Il legno massello è molto sensibile alla luce, il posizionamento vicino a sorgenti di luce naturale ne compromette la colorazione e la stabilità. Un'elevata variazione della temperatura e umidità dell'aria può provocare la comparsa di microfratture e leggere variazioni.

Armchair with internal structure in wood, by-products and metal parts. Padded with non-deformable foam polyurethane in different densities and polyester fibre. Solid wood base in black open pore stained ash. Also available version with 360° swivel movement with return and black painted steel structure covered by black open pore stained solid ash, to be confirmed when ordering. Available covered by fabric or leather as per samples.

! Removable cover.

Solid wood is very light-sensitive, placing it near natural light sources may compromise its colour and stability. Considerable differences in air temperature and humidity may cause microfractures and slight variations.



Cm  
85 x 74 x 66

Inches  
33½" x 29¼" x 26"

[For technical drawing / p. 247](#)

[Pricelist 2023 / p. 112](#)  
[Homescapes, embracing beauty / pp. 47, 100](#)  
[Homescapes, intimate portraits / p. 102](#)  
[Homescapes, gentle attitude / pp. 72, 73, 76, 104](#)

## BASE/BASE

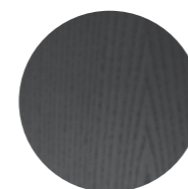

Frassino tinto nero  
a poro aperto  
Black open pore  
stained ash

## RIVESTIMENTO/COVER



Tessuto/pelle nei colori  
del campionario  
Fabric/leather as per  
samples.



# Sophie

Federica Biasi / 2018

Poltrona con imbottitura in poliuretano espanso indeformabile a densità differenziate e fibra poliestere. Rivestimento in tessuto nei colori del campionario. Rivestimento sfoderabile.  
Struttura in metallo laccato ottone satinato oppure grigio antracite. Bordo perimetrale nello stesso tessuto della poltrona. In caso di rivestimento in velluto il bordo perimetrale sarà realizzato in gros grain coordinandolo con il tessuto scelto per il rivestimento.

! Bordo perimetrale nello stesso tessuto della poltrona. In caso di rivestimento in velluto il bordo perimetrale sarà realizzato in gros grain coordinandolo con il tessuto scelto per il rivestimento.

Per la realizzazione di elementi con rivestimento in pelle sono necessarie cuciture aggiuntive rispetto gli elementi con rivestimento in tessuto.

Armchair with non-deformable polyurethane foam padding in differentiated densities and polyester fiber. Upholstery in fabric in sample colors. Removable cover.  
Satin brass or anthracite grey lacquered metal frame. Perimeter border in the same fabric as the armchair. In case of velvet upholstery, the perimeter border will be made of grosgrain coordinating with the fabric chosen for the upholstery.

! Perimeter trim in the same fabric of the armchair. In case of velvet cover the perimeter trim will be in gros grain matching it with the fabric chosen for the piece.

Additional stitching is required for elements with leather upholstery compared to elements with fabric upholstery.



**Cm**  
115 x 95 x 70

**Inches**  
45½" x 37½" x 27¾"

[For technical drawing / p. 247](#)

[Pricelist 2023 / p. 113](#)  
[Homescapes, sense of materials / p. 19](#)  
[Homescapes, gentle attitude / pp. 86, 87](#)

## STRUTTURA/STRUCTURE



**Metallo laccato  
ottone satinato**  
Satin brass  
lacquered metal



**Metallo laccato  
grigio antracite**  
Anthracite grey  
lacquered metal

## RIVESTIMENTO/COVER



**Tessuto nei colori  
del campionario**  
Fabric as per samples.

▲ **SOPHIE**  
Struttura in metallo laccato ottone satinato / Rivestimento in velvet Ash Pink 2703  
Satin brass structure / Cover in velvet Ash Pink 2703



▲ SOPHIE SOFA  
Struttura in metallo laccato grigio antracite / Rivestimento in Della Brick 046  
Anthracite grey lacquered metal structure / Cover in Della Brick 046

# Sophie Sofa

Federica Biasi / 2019

Divanetto con imbottitura in poliuretano espanso indeformabile a densità differenziate e fibra poliestere. Rivestimento in tessuto nei colori del campionario. Rivestimento sfoderabile.  
Struttura in metallo laccato ottone satinato oppure grigio antracite.

! Bordo perimetrale nello stesso tessuto del divanetto. In caso di rivestimento in velluto il bordo perimetrale sarà realizzato in gros grain coordinandolo con il tessuto scelto per il rivestimento.

Per la realizzazione di elementi con rivestimento in pelle sono necessarie cuciture aggiuntive rispetto gli elementi con rivestimento in tessuto.

Sofa with non-deformable polyurethane foam padding in differentiated densities and polyester fiber. Upholstery in fabric in sample colors.  
Removable cover.  
Satin brass or anthracite grey lacquered metal frame.

! Perimeter border in the same fabric as the sofa. In case of velvet upholstery, the perimeter border will be made of grosgrain coordinating with the fabric chosen for the upholstery.

Additional stitching is required for elements with leather upholstery compared to elements with fabric upholstery.



**Cm**  
170 x 95 x 70

**Inches**  
67" x 37½" x 27¾"

[For technical drawing / p. 247](#)

[Pricelist 2023 / p. 114](#)  
[Homescapes, sense of materials / p. 19](#)  
[Homescapes, gentle attitude / pp. 86, 87](#)

## STRUTTURA/STRUCTURE



Metallo laccato  
ottone satinato  
Satin brass  
lacquered metal



Metallo laccato  
grigio antracite  
Anthracite grey  
lacquered metal

## RIVESTIMENTO/COVER



Tessuto nei colori del  
campionario  
Fabric as per samples.



▲ STAMI LOUNGE  
Struttura in frassino tinto nero poro aperto / Rivestimento in Fard silt 2324  
Black open pore stained ash base / Cover in Fard silt 2324

# Stami Lounge

Studiopepe / 2023

Poltrona con base in frassino curvato tinto nero a poro aperto e dettagli in ottone lucido. Disponibile anche versione laccata opaca nei colori: "Bianco Camargue", "Sabbia del Nilo", "Rosa Jaipur", "Rosso Persia", "Bordeaux Etruria", "Verde Provenza", "Blu Pacifico", "Grigio Londra" e "Nero Giza". Imbottita in poliuretano espanso rivestito in tessuto o pelle nei colori del campionario. Fornita di un cuscino diam. cm 38 in piuma rivestito nello stesso rivestimento.

Armchair with curved black open pore stained ash base and bright brass details. Also available opaque lacquered wooden version in the colours "Bianco Camargue", "Sabbia del Nilo", "Rosa Jaipur", "Rosso Persia", "Bordeaux Etruria", "Verde Provenza", "Blu Pacifico", "Grigio Londra" and "Nero Giza". Padding in polyurethane foam covered by fabric or leather as per samples. A diam. 38 cm downpadding cushion covered in the same finish of the armchair included.

! Rivestimento sfoderabile.

Per la realizzazione di prodotti con rivestimento in pelle sono necessarie cuciture aggiuntive rispetto ai prodotti con rivestimento in tessuto.

! Removable cover.

Additional stitching is required for products with leather upholstery compared to products with fabric upholstery.



**Cm**  
76 x 67,5 x 69,5

**Inches**  
30" x 26¾" x 27½"

**Cuscino**  
Ø38

**Cushion**  
Ø15"

[For technical drawing / p. 248](#)

[Pricelist 2023 / p. 115](#)

BASE/BASE

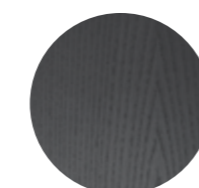

Frassino curvato tinto  
nero poro aperto  
Curved black open pore  
stained ash



Laccato opaco  
"Bianco Camargue"  
Opaque lacquered  
"Bianco Camargue"



Laccato opaco  
"Sabbia del Nilo"  
Opaque lacquered  
"Sabbia del Nilo"

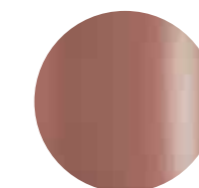

Laccato opaco  
"Rosa Jaipur"  
Opaque lacquered  
"Rosa Jaipur"

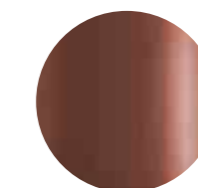

Laccato opaco  
"Rosso Persia"  
Opaque lacquered  
"Rosso Persia"

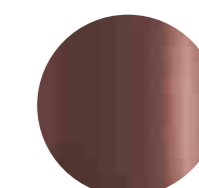

Laccato opaco  
"Bordeaux Etruria"  
Opaque lacquered  
"Bordeaux Etruria"

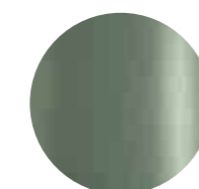

Laccato opaco  
"Verde Provenza"  
Opaque lacquered  
"Verde Provenza"

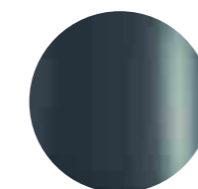

Laccato opaco  
"Blu Pacifico"  
Opaque lacquered "Blu  
Pacifico"



Laccato opaco  
"Grigio Londra"  
Opaque lacquered  
"Grigio Londra"



Laccato opaco "Nero Giza"  
Opaque lacquered  
"Nero Giza"



RIVESTIMENTO/COVER

Sample box  
COVERS

Tessuto/pelle nei colori del  
campionario  
Fabric as per samples.



DETTAGLI/DETAILS

Ottone lucido  
Bright brass



▲ STAMI LOVESEAT  
Struttura in frassino tinto nero poro aperto / Rivestimento in Fard silver 2302  
Black open pore stained ash base / Cover in Fard silver 2302

# Stami Loveseat

Studiopepe / 2024

Divanetto con base in frassino curvato tinto nero a poro aperto e dettagli in ottone lucido. Disponibile anche versione laccata opaca nei colori: "Bianco Camargue", "Sabbia del Nilo", "Rosa Jaipur", "Rosso Persia", "Bordeaux Etruria", "Verde Provenza", "Blu Pacifico", "Grigio Londra" e "Nero Giza". Imbottita in poliuretano espanso rivestito in tessuto o pelle nei colori del campionario. Fornita di due cuscini diam. cm 38 in piuma rivestiti nello stesso rivestimento.

Small sofa with curved black open pore stained ash base and bright brass details. Also available opaque lacquered wooden version in the colours "Bianco Camargue", "Sabbia del Nilo", "Rosa Jaipur", "Rosso Persia", "Bordeaux Etruria", "Verde Provenza", "Blu Pacifico", "Grigio Londra" and "Nero Giza". Padding in polyurethane foam covered by fabric or leather as per samples.

Supplied with two diam. 38 cm downpadding cushion covered in the same finish of the armchair included.

! **Rivestimento sfoderabile.**

Per la realizzazione di prodotti con rivestimento in pelle sono necessarie cuciture aggiuntive rispetto ai prodotti con rivestimento in tessuto.

! **Removable cover.**

Additional stitching is required for products with leather upholstery compared to products with fabric upholstery.



**Cm**  
121 x 67,5 x 69,5

**Inches**  
47¾" x 26¾" x 27½"

**Cuscini**  
Ø38

**Cushions**  
Ø15"

[For technical drawing / p. 248](#)

[Pricelist 2023 / p. 115](#)

**BASE/BASE**

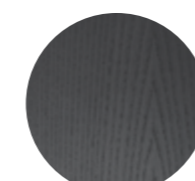

Frassino curvato tinto  
nero poro aperto  
Curved black open pore  
stained ash



Laccato opaco  
"Bianco Camargue"  
Opaque lacquered  
"Bianco Camargue"



Laccato opaco  
"Sabbia del Nilo"  
Opaque lacquered  
"Sabbia del Nilo"

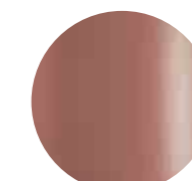

Laccato opaco  
"Rosa Jaipur"  
Opaque lacquered  
"Rosa Jaipur"

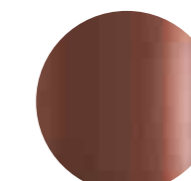

Laccato opaco  
"Rosso Persia"  
Opaque lacquered  
"Rosso Persia"

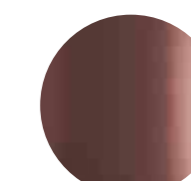

Laccato opaco  
"Bordeaux Etruria"  
Opaque lacquered  
"Bordeaux Etruria"

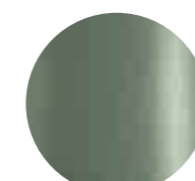

Laccato opaco  
"Verde Provenza"  
Opaque lacquered  
"Verde Provenza"

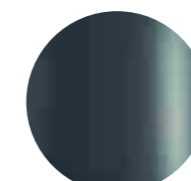

Laccato opaco  
"Blu Pacifico"  
Opaque lacquered "Blu  
Pacifico"

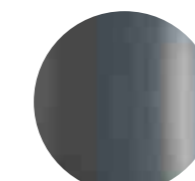

Laccato opaco  
"Grigio Londra"  
Opaque lacquered  
"Grigio Londra"



Laccato opaco "Nero Giza"  
Opaque lacquered  
"Nero Giza"

**RIVESTIMENTO/COVER**



Sample box  
COVERS

Tessuto/pelle nei colori del  
campionario  
Fabric as per samples.

**DETTAGLI/DETAILS**



Ottone lucido  
Bright brass

# Stami Sofa

Studiopepe / 2024

Divano con base in frassino curvato tinto nero a poro aperto e dettagli in ottone lucido. Disponibile anche versione laccata opaca nei colori: "Bianco Camargue", "Sabbia del Nilo", "Rosa Jaipur", "Rosso Persia", "Bordeaux Etruria", "Verde Provenza", "Blu Pacifico", "Grigio Londra" e "Nero Giza". Imbottito in poliuretano espanso e piuma d'oca. Rivestito in tessuto o pelle nei colori del campionario. Fornito di due braccioli terminali cilindrici in piuma rivestiti nello stesso tessuto/pelle del divano.

! Rivestimento sfoderabile, non disponibile per le seguenti categorie: Cat. L1, L2 e pelle cliente/C.O.L.

Per la realizzazione di elementi con rivestimento in pelle sono necessarie cuciture aggiuntive rispetto gli elementi con rivestimento in tessuto.

Sofa with curved ashwood base stained black open pore and polished brass details. Also available matte lacquered version in colors: "Bianco Camargue", "Sabbia del Nilo", "Rosa Jaipur", "Rosso Persia", "Bordeaux Etruria", "Verde Provenza", "Blu Pacifico", "Grigio Londra" and "Nero Giza". Padded with polyurethane foam and goose down. Upholstered in fabric or leather in sample colors. Supplied with two cylindrical feather end arms covered in the same fabric/leather as the sofa.

! Removable cover, not available for the following categories: Cat. L1, L2 and customer leather/C.O.L.

Additional stitching is required for leather-covered elements compared to fabric-covered elements.



	Cm	Inches
STAMI220	219 x 96 x 73	86¼" x 38" x 28¾"
STAMI250	249 x 96 x 73	98¼" x 38" x 28¾"
STAMI280	279 x 96 x 73	110" x 38" x 28¾"

VERSIONE VIS A VIS	Cm	Inches
STAMI280-VIS L/R	219 x 96 x 73	86¼" x 38" x 28¾"
STAMI250-VIS L/R	249 x 96 x 73	98¼" x 38" x 28¾"
STAMI280-VIS L/R	279 x 96 x 73	110" x 38" x 28¾"

[For technical drawing / p. 249](#)

[Pricelist 2023 / p. 115](#)

## BASE/BASE

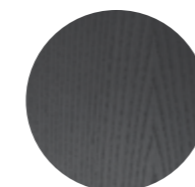

Frassino curvato tinto  
nero poro aperto  
Curved black open pore  
stained ash



Laccato opaco  
"Bianco Camargue"  
Opaque lacquered  
"Bianco Camargue"



Laccato opaco  
"Sabbia del Nilo"  
Opaque lacquered  
"Sabbia del Nilo"



Laccato opaco  
"Rosa Jaipur"  
Opaque lacquered  
"Rosa Jaipur"

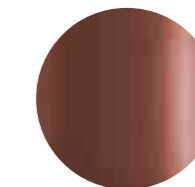

Laccato opaco  
"Rosso Persia"  
Opaque lacquered  
"Rosso Persia"

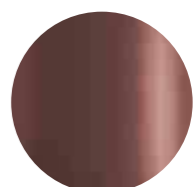

Laccato opaco  
"Bordeaux Etruria"  
Opaque lacquered  
"Bordeaux Etruria"

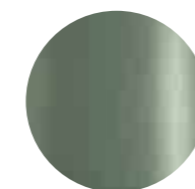

Laccato opaco  
"Verde Provenza"  
Opaque lacquered  
"Verde Provenza"

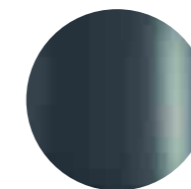

Laccato opaco  
"Blu Pacifico"  
Opaque lacquered "Blu  
Pacifico"

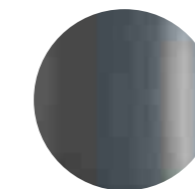

Laccato opaco  
"Grigio Londra"  
Opaque lacquered  
"Grigio Londra"



Laccato opaco "Nero Giza"  
Opaque lacquered  
"Nero Giza"



Tessuto/pelle nei colori del  
campionario  
Fabric as per samples.

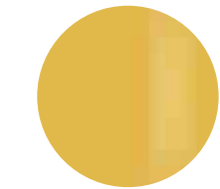

Ottone lucido  
Bright brass

## RIVESTIMENTO/COVER

## DETTAGLI/DETAILS



▲ **STAMI SOFA PLUS**  
Struttura laccato opaco "Sabbia del Nilo" / Rivestimento in Origine milk 001  
Opaque lacquered "Sabbia del Nilo" structure / Cover in Origine milk 001

# Stami Sofa Plus

Studiopepe / 2024

Divano modulare con base in frassino curvato tinto nero a poro aperto e dettagli in ottone lucido. Disponibile anche versione laccata opaca nei colori: "Bianco Camargue", "Sabbia del Nilo", "Rosa Jaipur", "Rosso Persia", "Bordeaux Etruria", "Verde Provenza", "Blu Pacifico", "Grigio Londra" e "Nero Giza". Imbottito in poliuretano espanso e piuma d'oca rivestito in tessuto o pelle nei colori del campionario. Modulo terminale fornito di bracciolo terminale cilindrico in piuma rivestito nello stesso rivestimento del divano.

! Rivestimento sfoderabile, non disponibile per le seguenti categorie: Cat. L1, L2 e pelle cliente/C.O.L.

Per la realizzazione di elementi con rivestimento in pelle sono necessarie cuciture aggiuntive rispetto gli elementi con rivestimento in tessuto.

Modular sofa with curved ashwood base stained black open pore and polished brass details. Also available matte lacquered version in colors: "Bianco Camargue", "Sabbia del Nilo", "Rosa Jaipur", "Rosso Persia", "Bordeaux Etruria", "Verde Provenza", "Blu Pacifico", "Grigio Londra" and "Nero Giza".

Upholstered in polyurethane foam and goose down covered in fabric or leather in the colors of the sample book. End module supplied with cylindrical feather end armrest covered in the same upholstery as the sofa.

! Removable cover, not available for the following categories: Cat. L1, L2 and customer/C.O.L. leather.

Additional stitching is required for elements with leather upholstery compared to elements with fabric upholstery.



	Cm	Inches
SPLUS-T110	109,5 x 96 x 73	43¼" x 38" x 28¾"
SPLUS-T125	124,5 x 96 x 73	49¼" x 38" x 28¾"
SPLUS-T140	139,5 x 96 x 73	55" x 38" x 28¾"
SPLUS-A137	136,5 x 136,5 x 73	53¾" x 53¾" x 28¾"
SPLUS-C108	108 x 96 x 73	42¾" x 38" x 28¾"
SPLUS-C123	123 x 96 x 73	48½" x 38" x 28¾"
SPLUS-C138	138 x 96 x 73	54½" x 38" x 28¾"
SPLUS-POUF108	108 x 96 x 43	42¾" x 38" x 17"
SPLUS-POUF123	123 x 96 x 43	48½" x 38" x 17"
SPLUS-POUF138	138 x 96 x 43	54½" x 38" x 17"

[For technical drawing / p. 250](#)

[Pricelist 2023 / p. 115](#)

## BASE/BASE

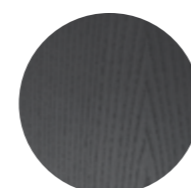

Frassino curvato tinto  
nero poro aperto  
Curved black open pore  
stained ash



Laccato opaco  
"Bianco Camargue"  
Opaque lacquered  
"Bianco Camargue"



Laccato opaco  
"Sabbia del Nilo"  
Opaque lacquered  
"Sabbia del Nilo"

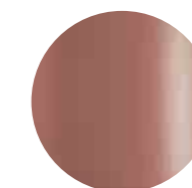

Laccato opaco  
"Rosa Jaipur"  
Opaque lacquered  
"Rosa Jaipur"

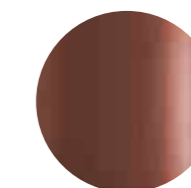

Laccato opaco  
"Rosso Persia"  
Opaque lacquered  
"Rosso Persia"

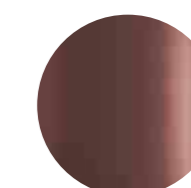

Laccato opaco  
"Bordeaux Etruria"  
Opaque lacquered  
"Bordeaux Etruria"

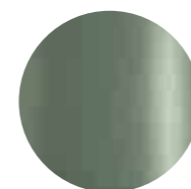

Laccato opaco  
"Verde Provenza"  
Opaque lacquered  
"Verde Provenza"

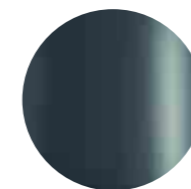

Laccato opaco  
"Blu Pacifico"  
Opaque lacquered "Blu  
Pacifico"

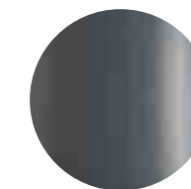

Laccato opaco  
"Grigio Londra"  
Opaque lacquered  
"Grigio Londra"



Laccato opaco "Nero Giza"  
Opaque lacquered  
"Nero Giza"



Tessuto/pelle nei colori del  
campionario  
Fabric as per samples.



Ottone lucido  
Bright brass

## RIVESTIMENTO/COVER

## DETTAGLI/DETAILS

Sample box  
COVERS



COMPOSITION 1



COMPOSITION 2



COMPOSITION 3



# 05

**Divani e Poltrone / Sofas and Armchairs**  
**TECHNICAL MODULE**





0417 | Studio G&R, 2017

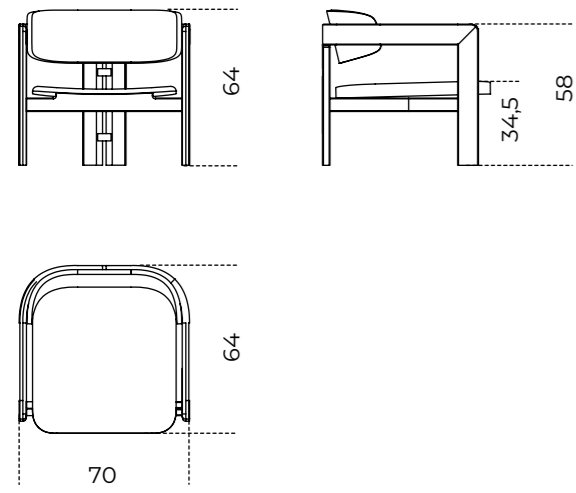

Product information / p.168

Audrey | Massimo Castagna, 2017

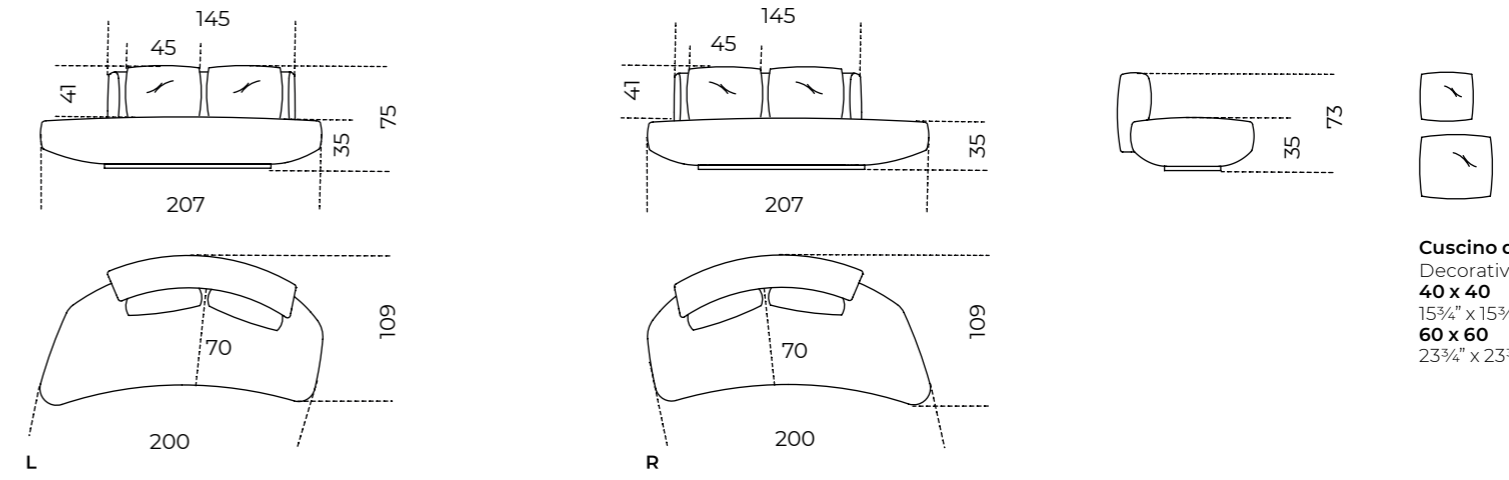

Product information / p.172

**Cuscino decorativo**  
Decorative cushion  
40 x 40  
15¾" x 15¾"  
60 x 60  
23¾" x 23¾"

Akiko Lounge | Oscar e Gabriele Buratti, 2022

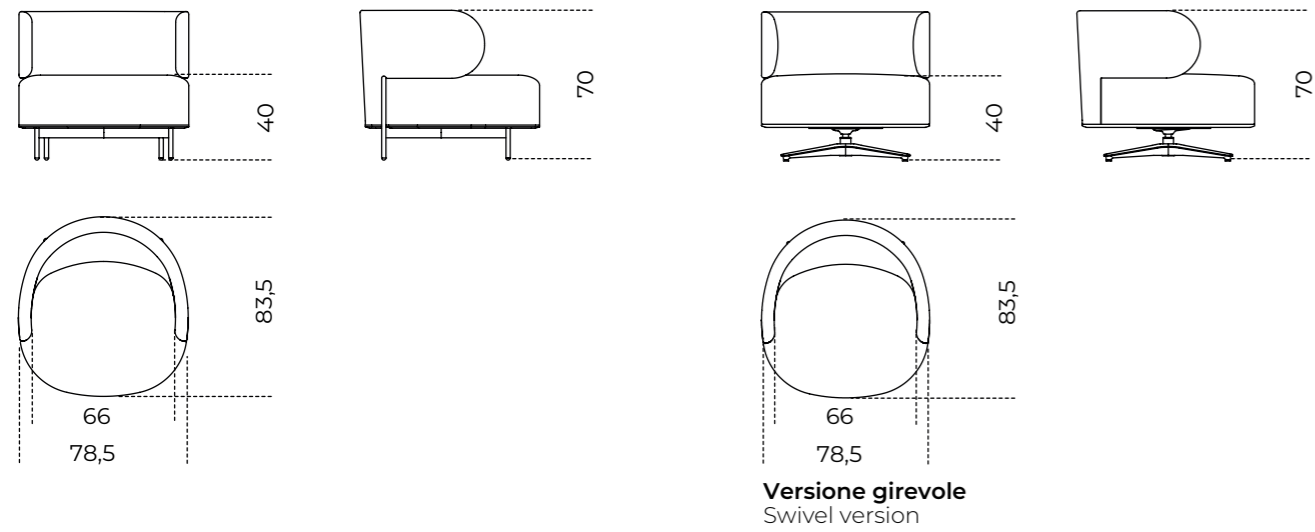

Product information / p.170

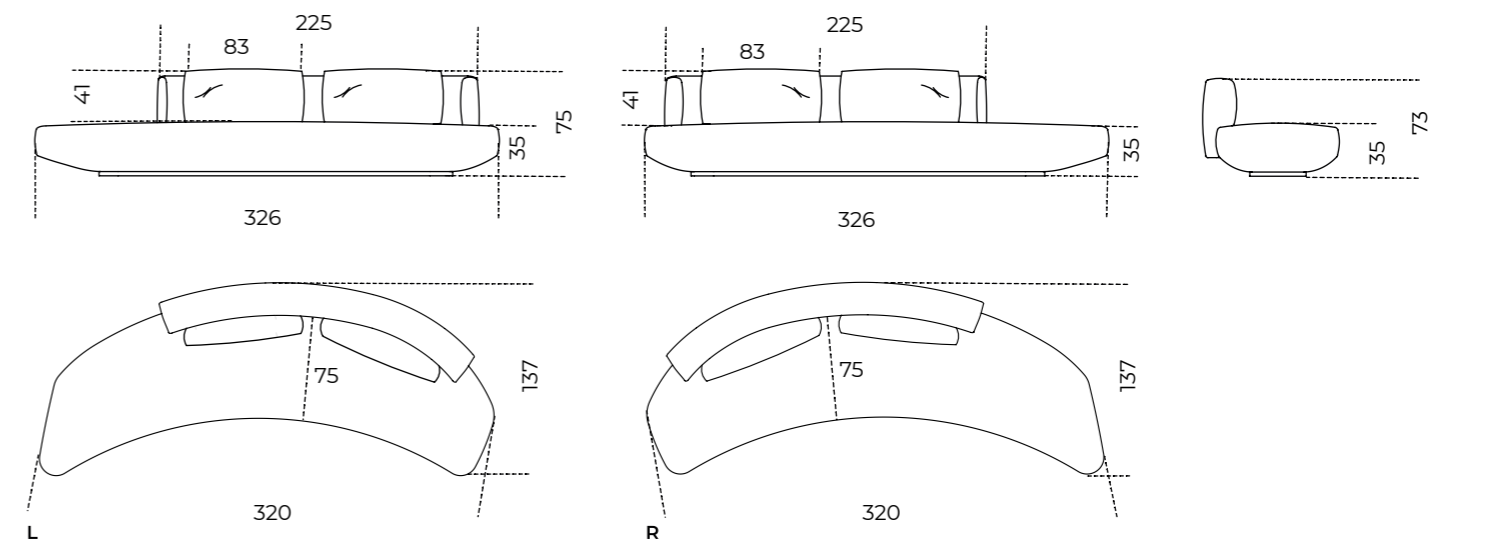
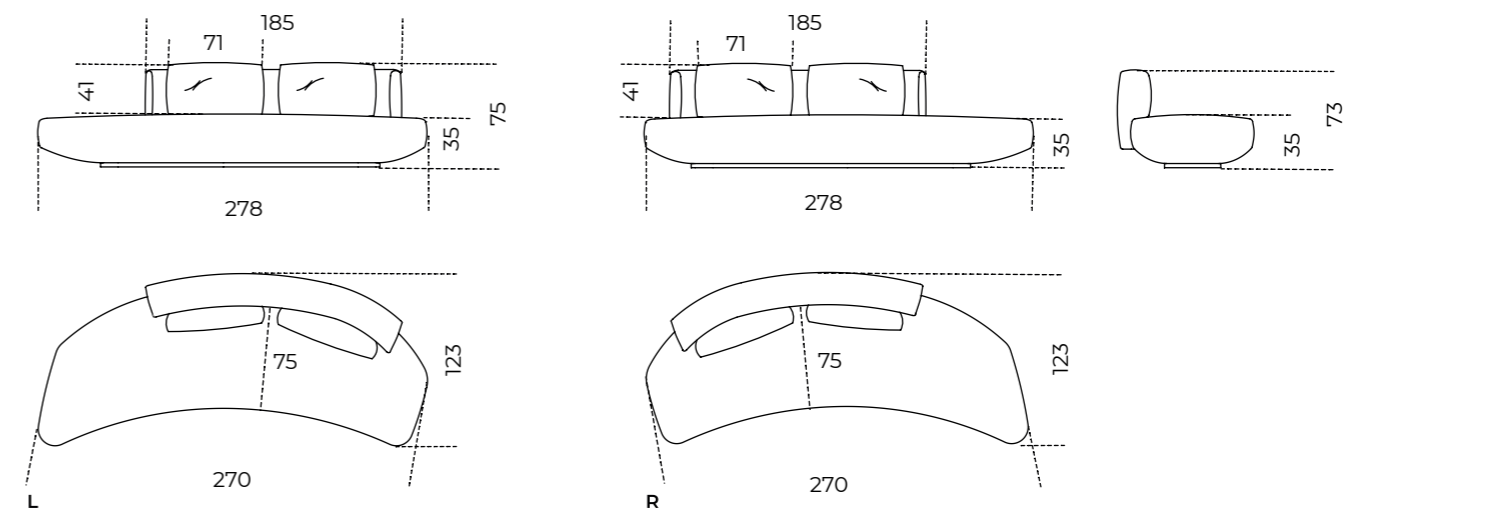
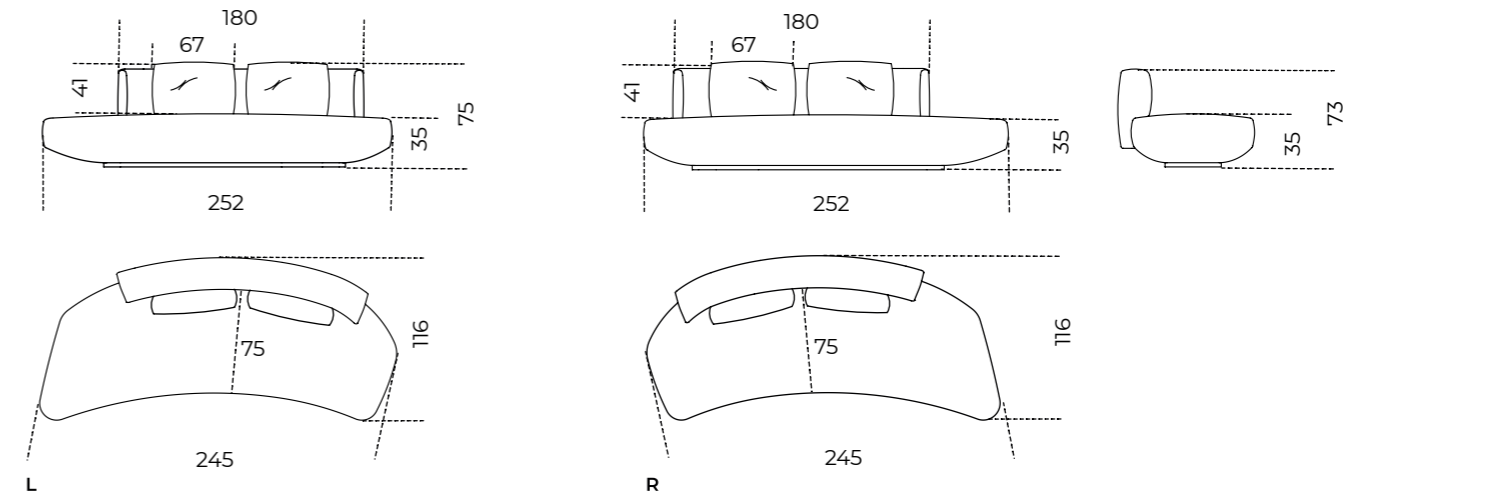

**Audrey Motion** | Massimo Castagna, 2020

Product information / p. 174

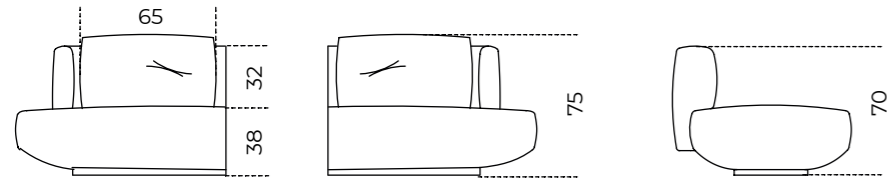

**Cuscino decorativo**  
Decorative cushion  
**40 x 40**  
15¾" x 15¾"  
**60 x 60**  
23¾" x 23¾"

**Moduli**  
Modules

**T115L / T115R**

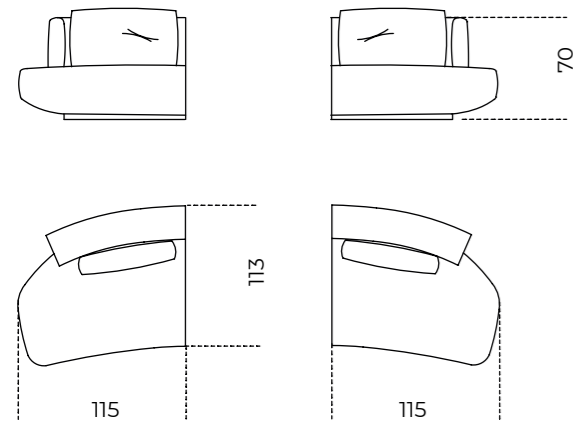

**T160L / T160R**

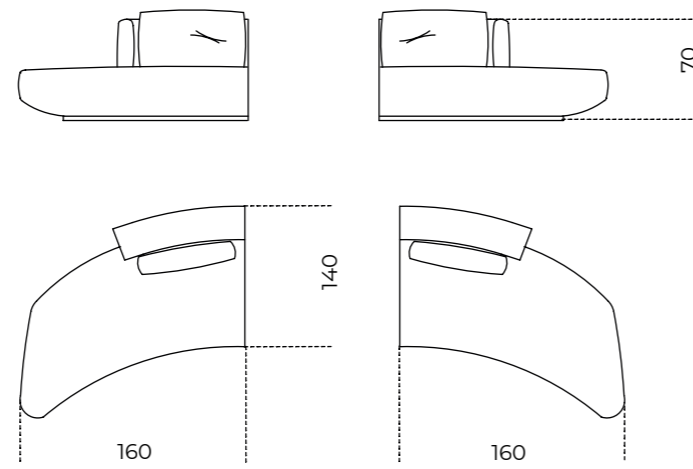

**C175**

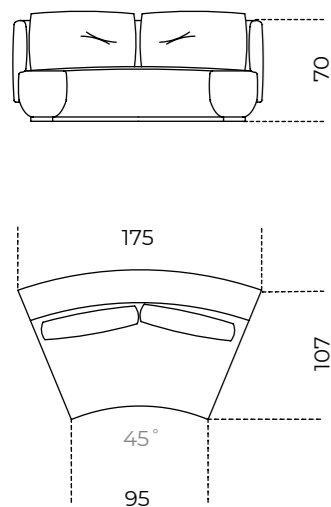

**C200**

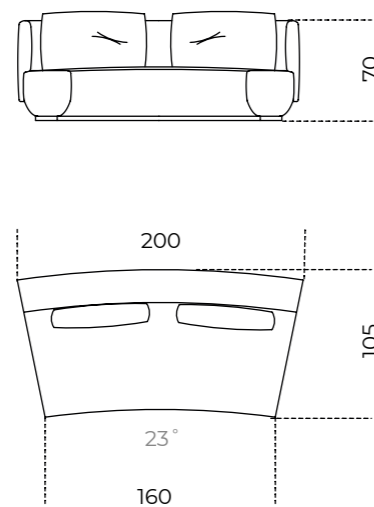

**C235**

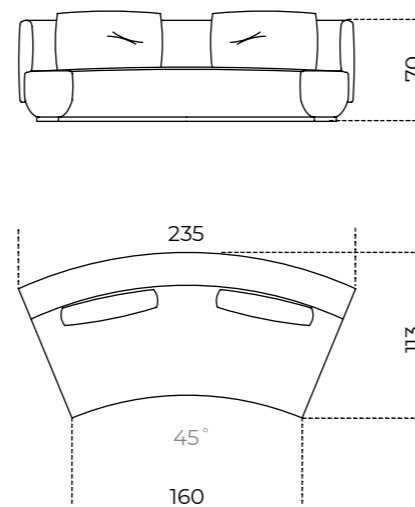

**Composizioni**  
Compositions

**Composizione 1 / Composition 1**

**431 x 190 x 73h**  
169½" x 75" x 28¾"h

**Composta da**  
Composed by  
**n.1 T160L**  
**n.1 C235**  
**n.1 T115R**

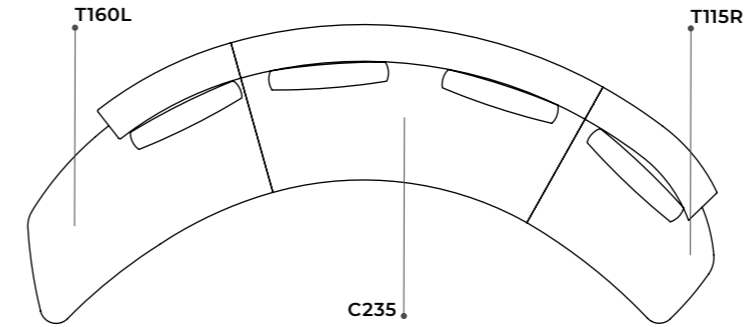

**Set cuscini decorativi consigliati (non inclusi):**  
Recommended decorative pillow sets (not included)  
**n.4 cm 60x60** | 23¾" x 23¾"  
**n.3 cm 40x40** | 15¾" x 15¾"

**Composizione 2 / Composition 2**

**437 x 245 x 73h**  
172¼" x 96½" x 28¾"h

**Composta da**  
Composed by  
**n.1 T160L**  
**n.2 C175**  
**n.1 T115R**

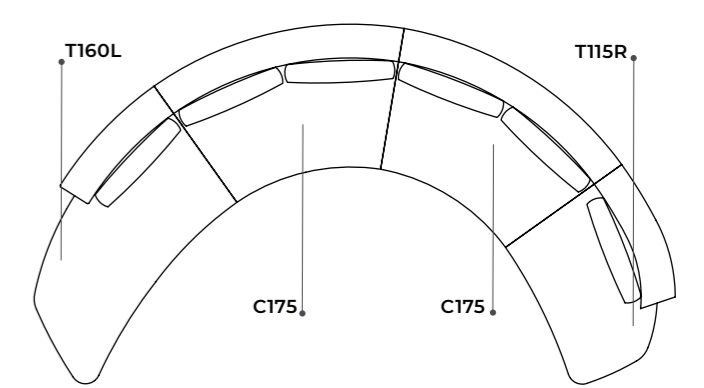

**Set cuscini decorativi consigliati (non inclusi):**  
Recommended decorative pillow sets (not included)  
**n.4 cm 60x60** | 23¾" x 23¾"  
**n.4 cm 40x40** | 15¾" x 15¾"

**Composizione 3 / Composition 3**

**507 x 236 x 73h**  
199¾" x 93" x 28¾"h

**Composta da**  
Composed by  
**n.1 T160L**  
**n.1 C175**  
**n.1 C200**  
**n.1 T115R**

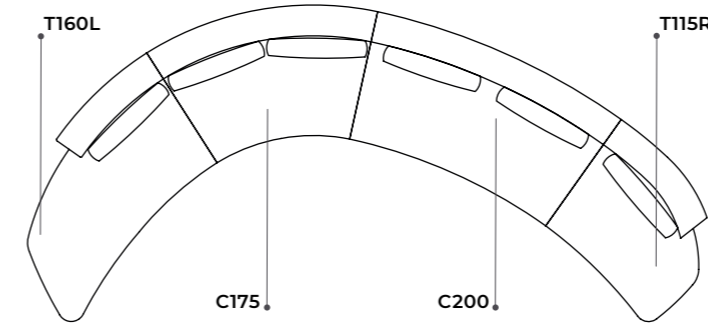

**Set cuscini decorativi consigliati (non inclusi):**  
Recommended decorative pillow sets (not included)  
**n.5 cm 60x60** | 23¾" x 23¾"  
**n.4 cm 40x40** | 15¾" x 15¾"

**Composizione 4 / Composition 4**

**575 x 236 x 73h**  
226½" x 93" x 28¾"h

**Composta da**  
Composed by  
**n.1 T160L**  
**n.1 C200**  
**n.1 C235**  
**n.1 T115R**

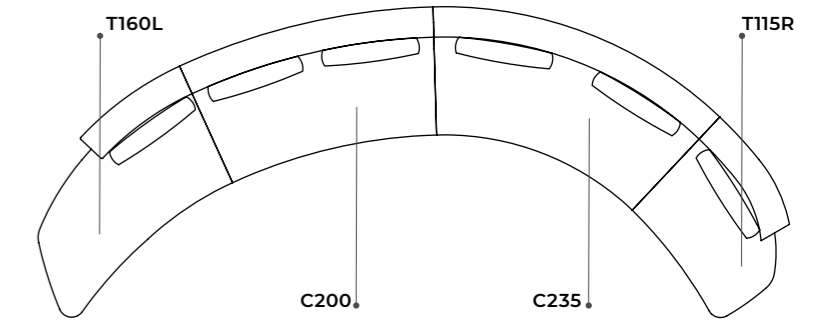

**Set cuscini decorativi consigliati (non inclusi):**  
Recommended decorative pillow sets (not included)  
**n.5 cm 60x60** | 23¾" x 23¾"  
**n.4 cm 40x40** | 15¾" x 15¾"

**Composizione 5 / Composition 5**

**676 x 177 x 73h**  
266¼" x 69¾" x 28¾"h

**Composta da**  
Composed by  
**n.2 T160L**  
**n.2 C235**

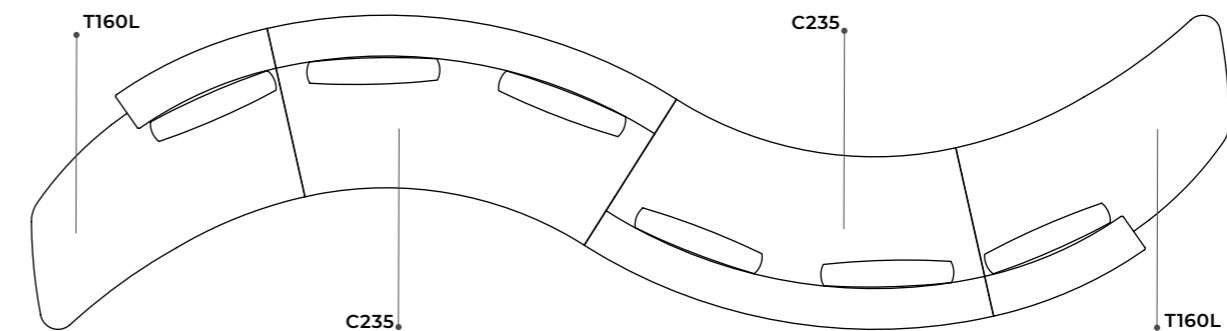

**Set cuscini decorativi consigliati (non inclusi):**  
Recommended decorative pillow sets (not included)  
**n.6 cm 60x60** | 23¾" x 23¾"  
**n.4 cm 40x40** | 15¾" x 15¾"

**Audrey Poltrona** | Massimo Castagna, 2018

Product information / p. 176

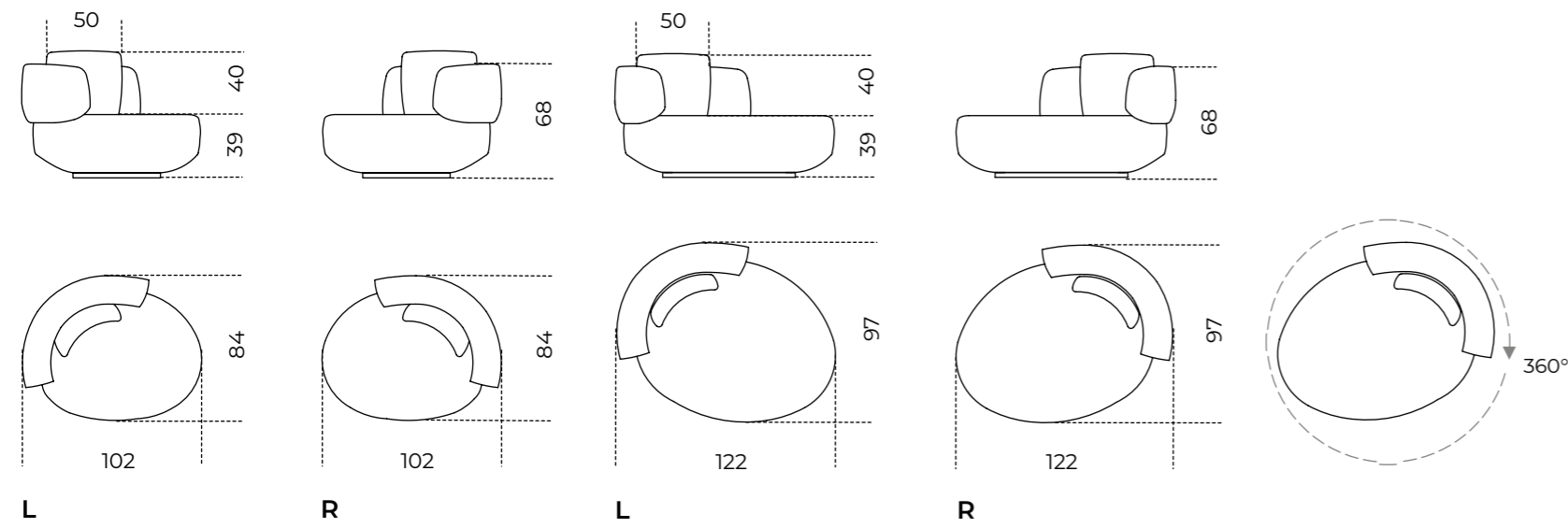

**Cloud** | Massimo Castagna, 2016

Product information / p. 178

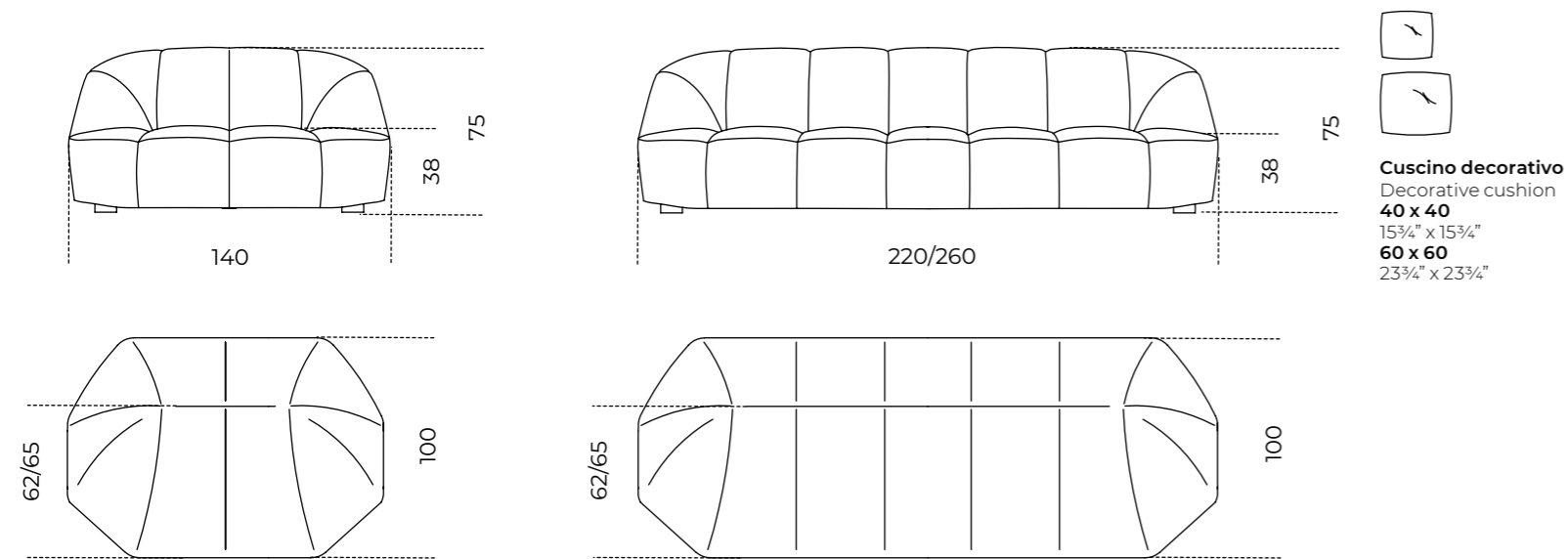

**Cloud Chaise Longue** | Massimo Castagna, 2024

Product information / p. 180

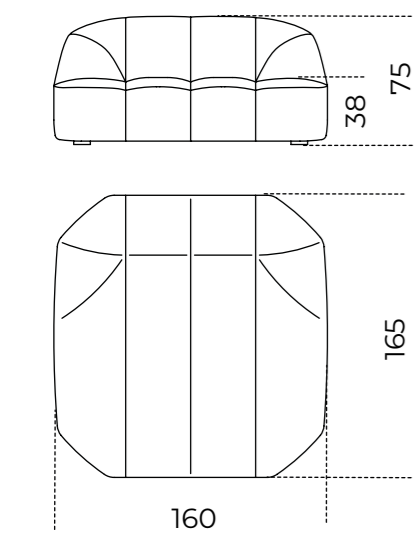

**Cloud Infinity** | Massimo Castagna, 2022

Product information / p. 182

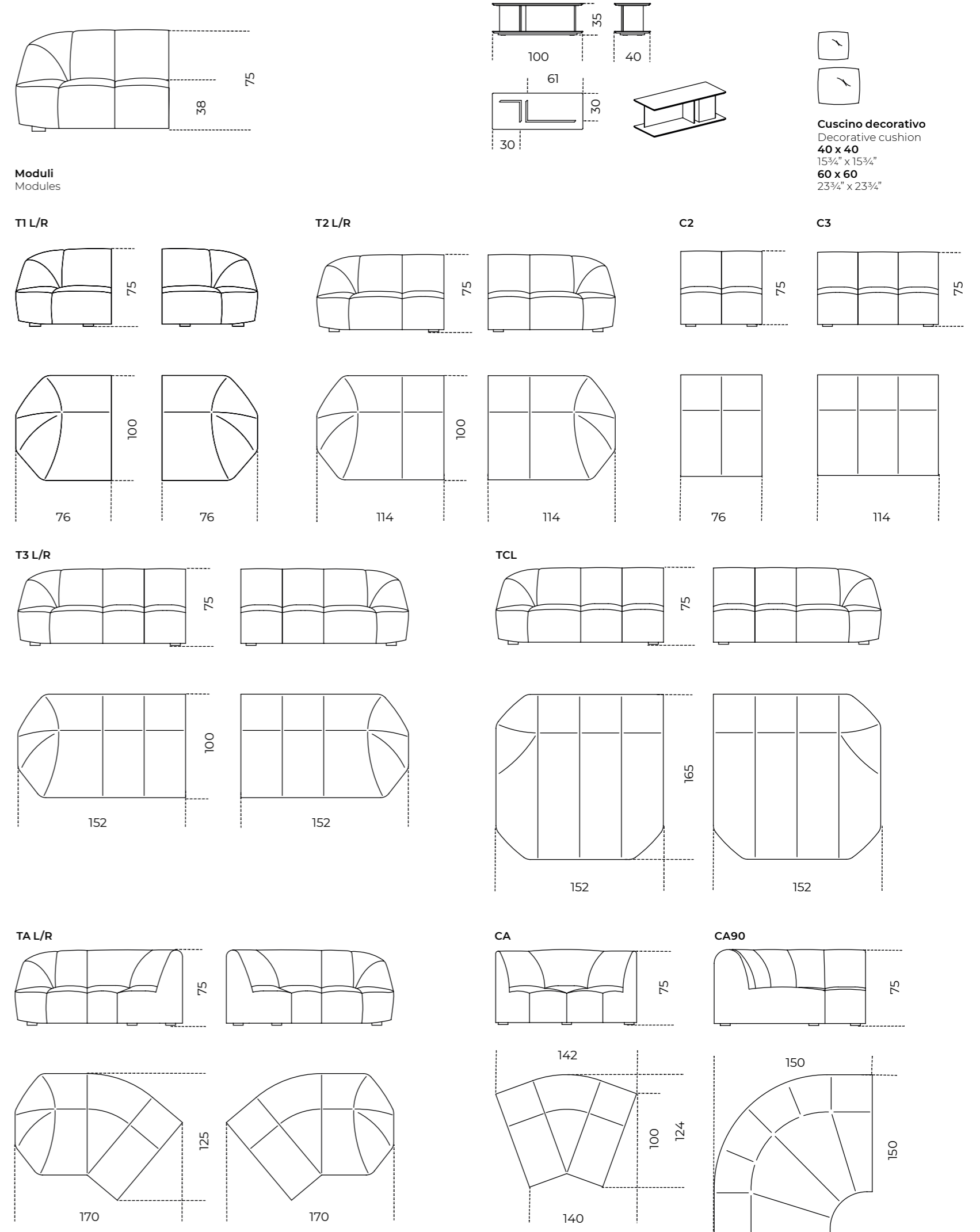

**Composizioni**  
Compositions

**Composizione 1 / Composition 1**

**276 x 131 x 75h**  
108¾" x 51¾" x 29¾"h

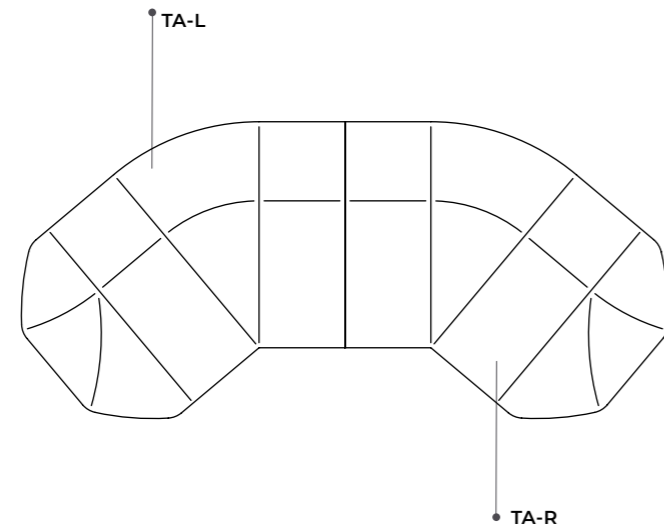

**Product information / p.182**

**Composta da**  
Composed by  
n.1 TA-L  
n.1 TA-R

**Composizioni**  
Compositions

**Composizione 3 / Composition 3**

**600 x 215 x 75h**  
236¼" x 84¾" x 29¾"h

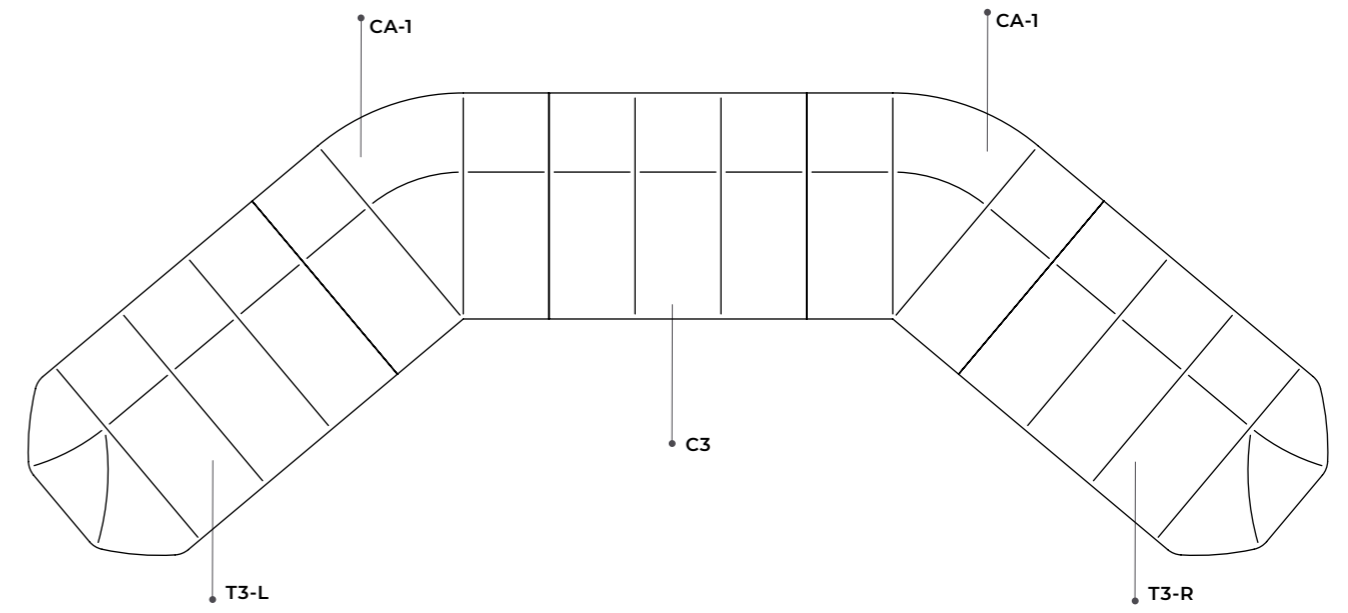

**Product information / p.182**

**Composta da**  
Composed by  
n.1 T3-L  
n.1 CA-1  
n.1 C-3  
n.1 CA-1  
n.1 T3-R

**Composizione 2 / Composition 2**

**396 x 131 x 75h**  
156" x 51¾" x 29¾"h

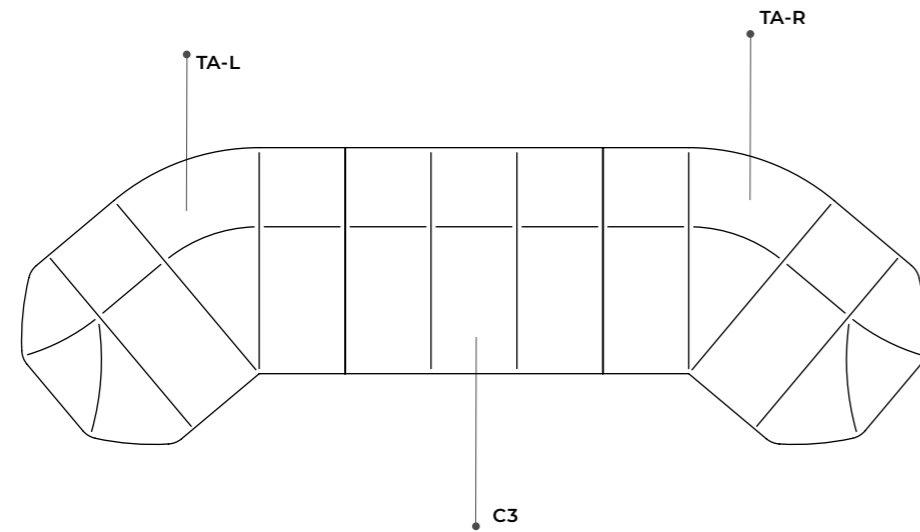

**Composta da**  
Composed by  
n.1 TA-L  
n.1 C-3  
n.1 TA-R

**Composizione 4 / Composition 4**

**436,5 x 232,5 x 75h**  
172" x 91¾" x 29¾"h

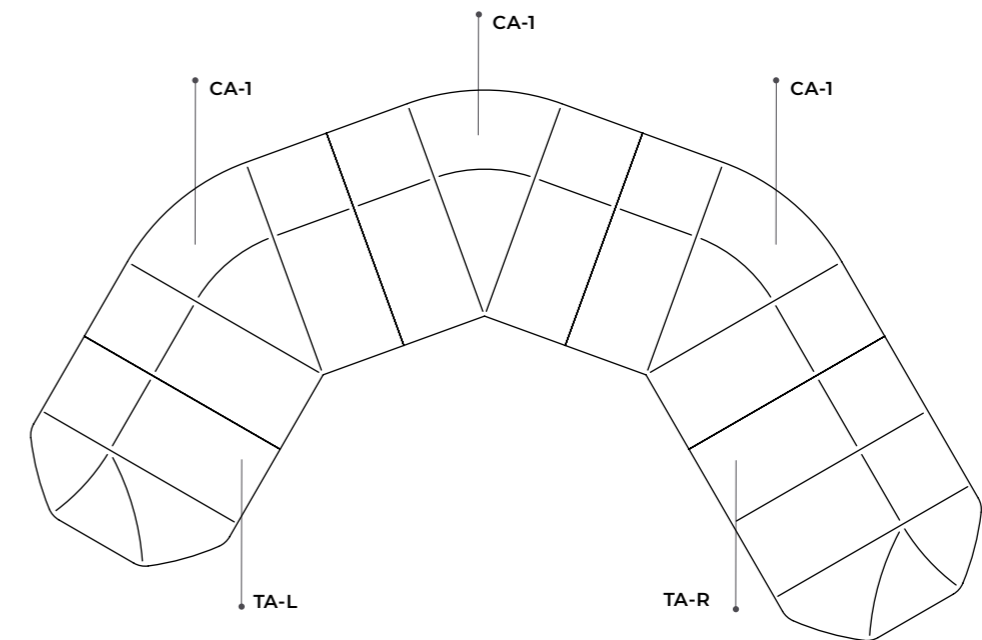

**Composta da**  
Composed by  
n.1 T1-L  
n.3 CA-1  
n.1 T2-R

**Composizioni**  
Compositions

Product information / p.182

**Composizione 5 / Composition 5**

**420 x 165 x 75h**  
165½" x 65" x 29¾"h

**Composta da**  
Composed by  
n.1 T3-L  
n.1 C2  
n.1 TCL-R  
n.1 side table

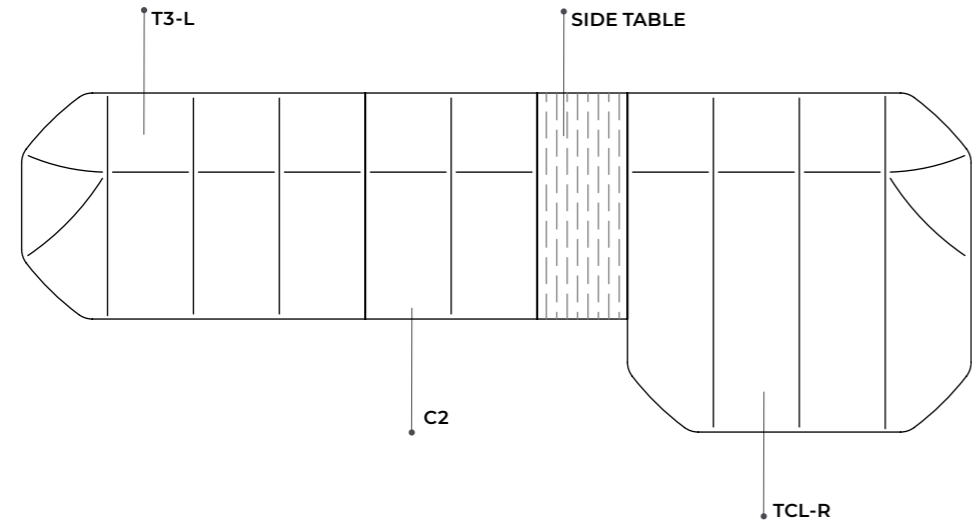

**Composizioni**  
Compositions

Product information / p.182

**Composizione 7 / Composition 7**

**520 x 305 x 75h**  
204¾" x 120¼" x 29¾"h

**Composta da**  
Composed by  
n.1 T1-L  
n.1 C3  
n.1 CA  
n.1 C2  
n.1 TCL-R  
n.1 side table

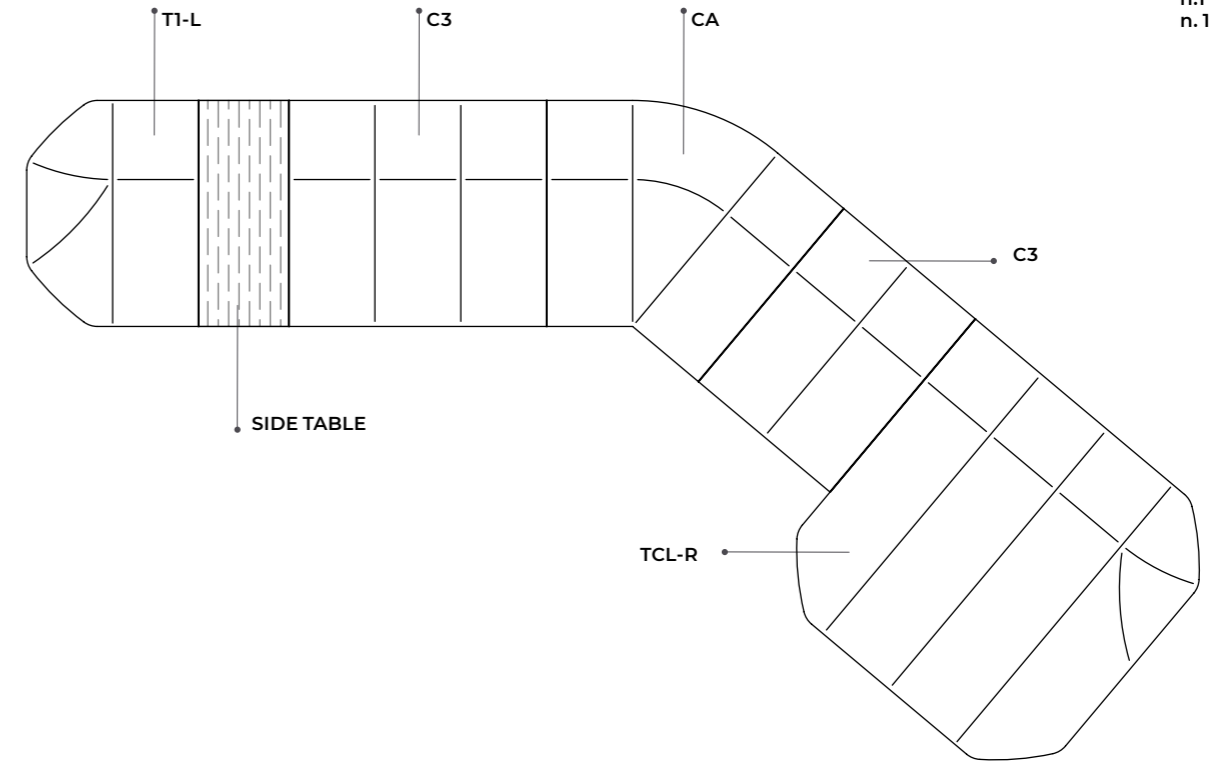

**Composizione 6 / Composition 6**

**635 x 280 x 75h**  
250¼" x 110¼" x 29¾"h

**Composta da**  
Composed by  
n.1 T2-L  
n.1 C2  
n.2 CA  
n.1 C3  
n.1 TCL-R  
n.1 side table

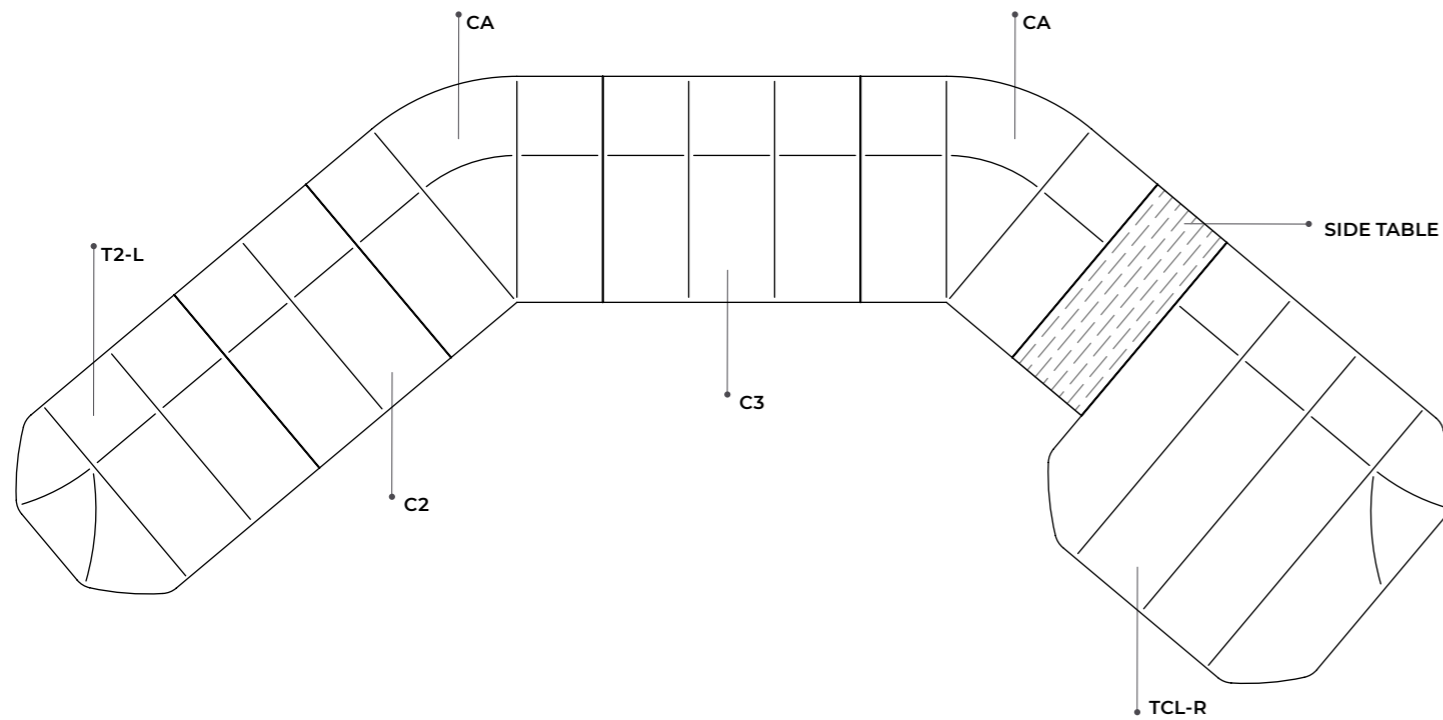

**Composizione 8 / Composition 8**

**523 x 370 x 75h**  
206" x 145¾" x 29¾"h

**Composta da**  
Composed by  
n.1 T3-L  
n.4 CA  
n.1 T3-R  
n. 3 small table

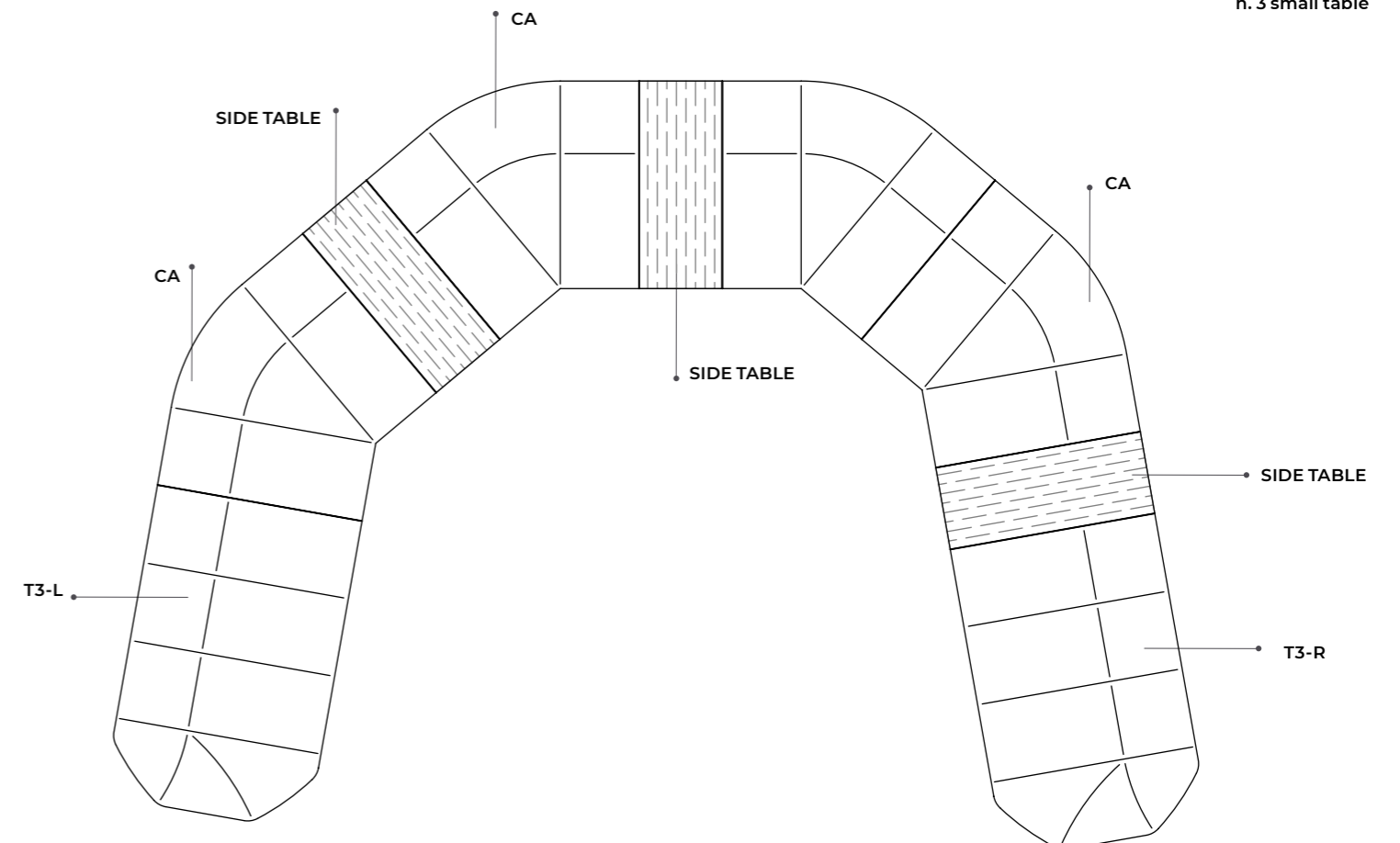

**Cloud Poltrona** | Massimo Castagna, 2016

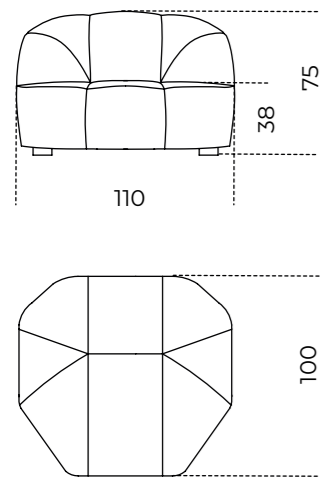

**Product information / p. 184**

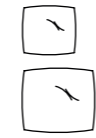

**Cuscino decorativo**  
Decorative cushion  
**40 x 40**  
15¾" x 15¾"  
**60 x 60**  
23¾" x 23¾"

**Elissa Sectional** | Dainelli Studio, 2021

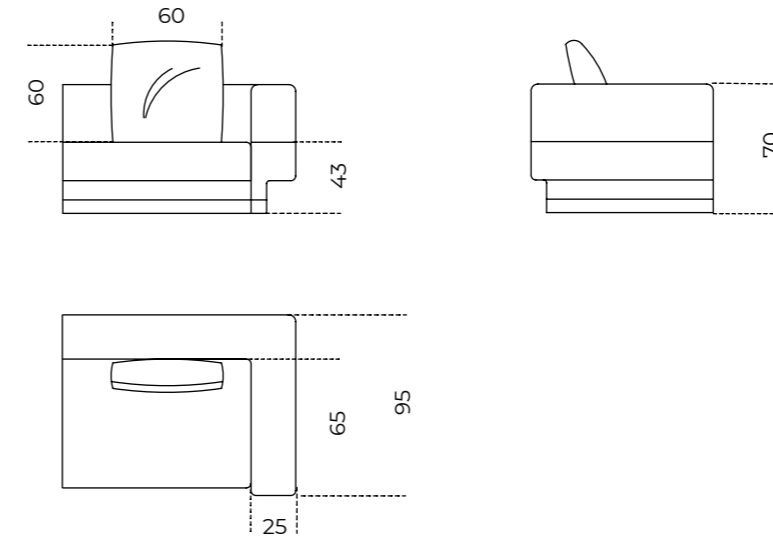

**Product information / p. 188**

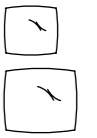

**Cuscino decorativo**  
Decorative cushion  
**40 x 40**  
15¾" x 15¾"  
**60 x 60**  
23¾" x 23¾"

**Elissa** | Dainelli Studio, 2020

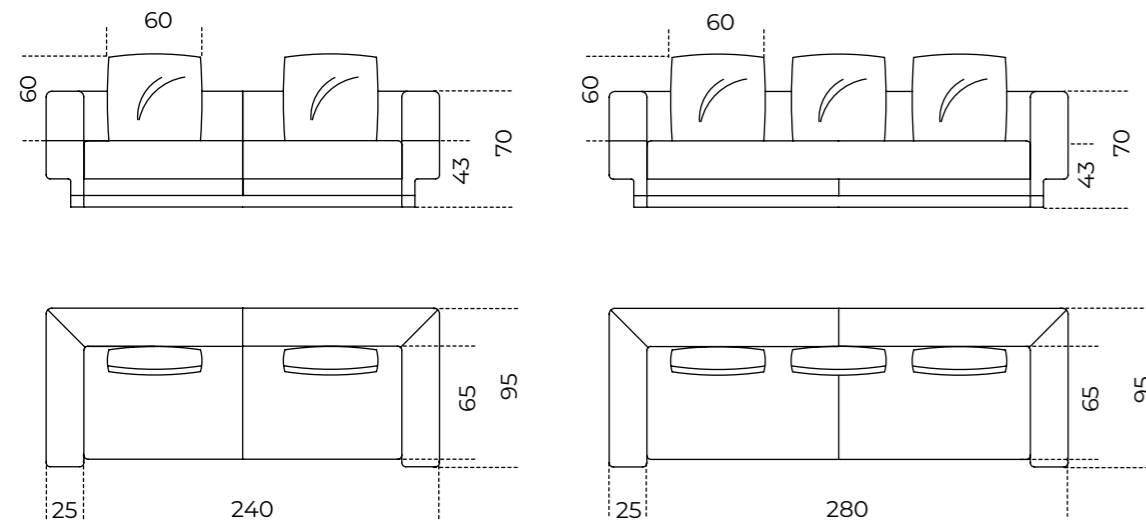

**Product information / p. 186**

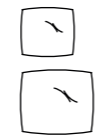

**Cuscino decorativo**  
Decorative cushion  
**40 x 40**  
15¾" x 15¾"  
**60 x 60**  
23¾" x 23¾"

**Moduli**  
Modules

**ELS-T120L/T120R**

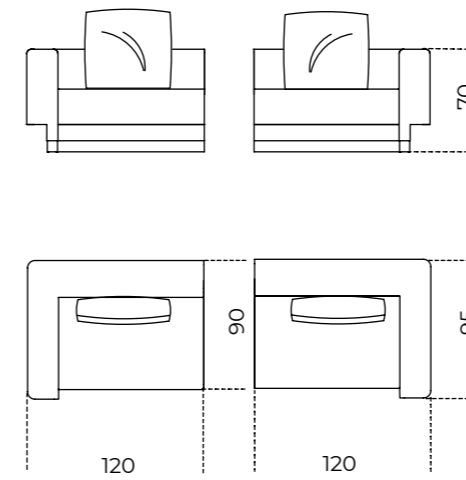

**ELS-T140L/T140R**

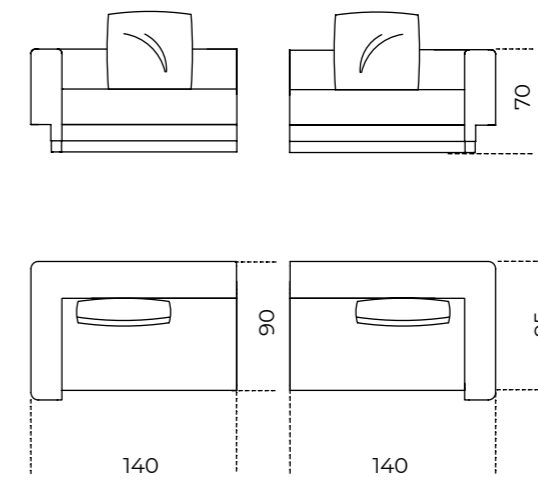

**ELS-A140L/A140R**

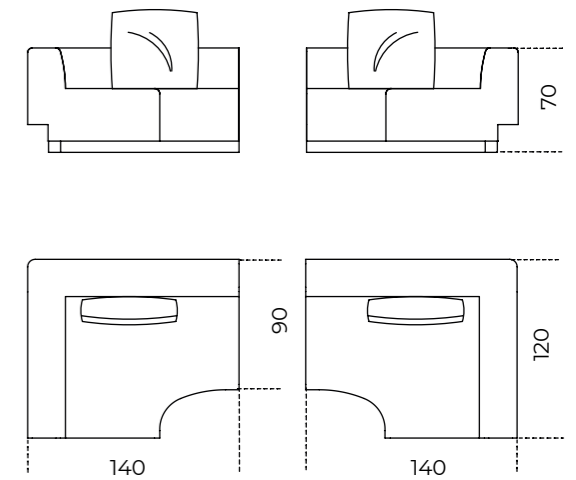

**ELS-T220L/T220R**

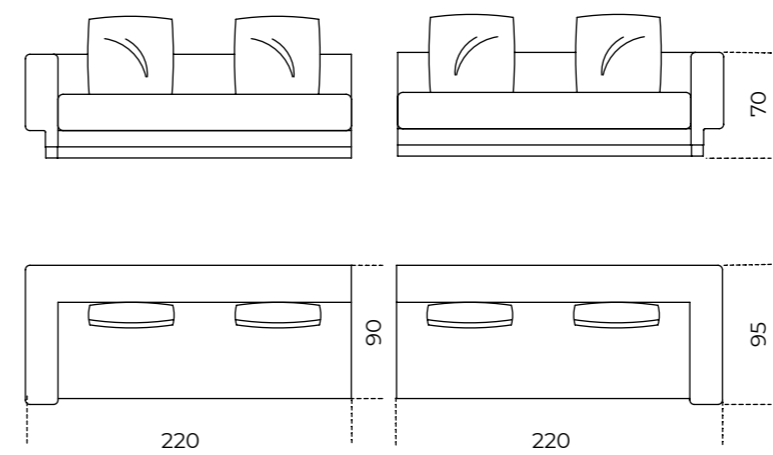

**ELS-T260L/T260R**

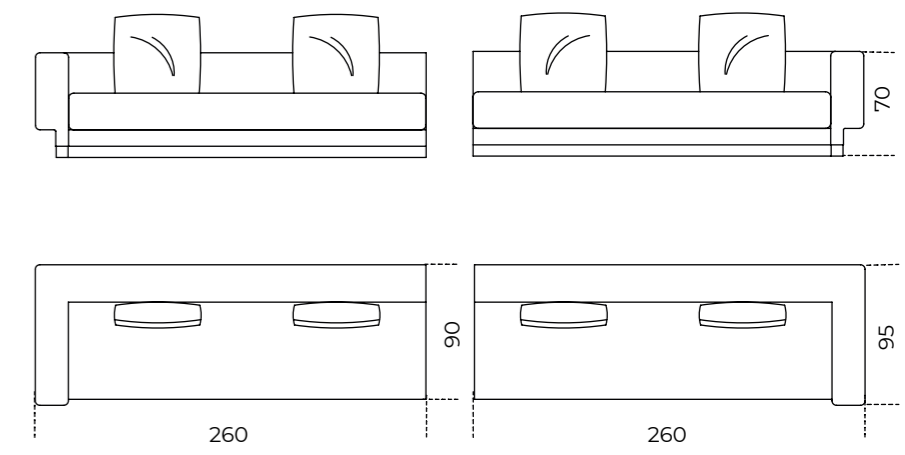

**Moduli**  
Modules

Product information / p.188

**ELS-TA225L/TA225R**

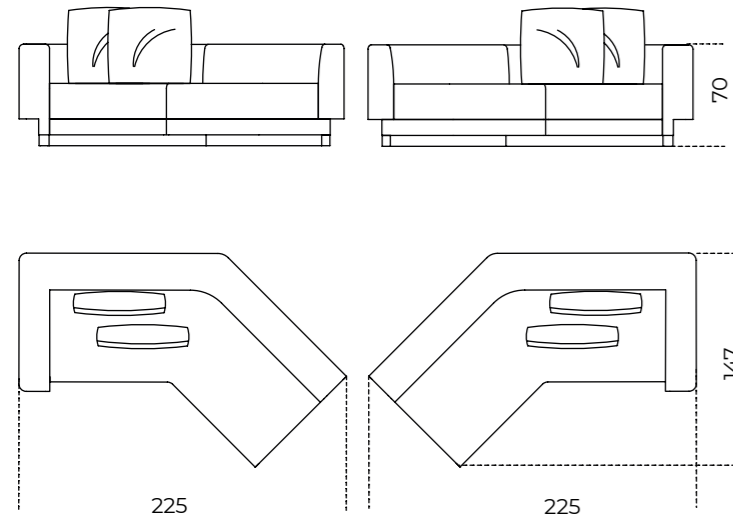

**ELS-TA240L/TA240R**

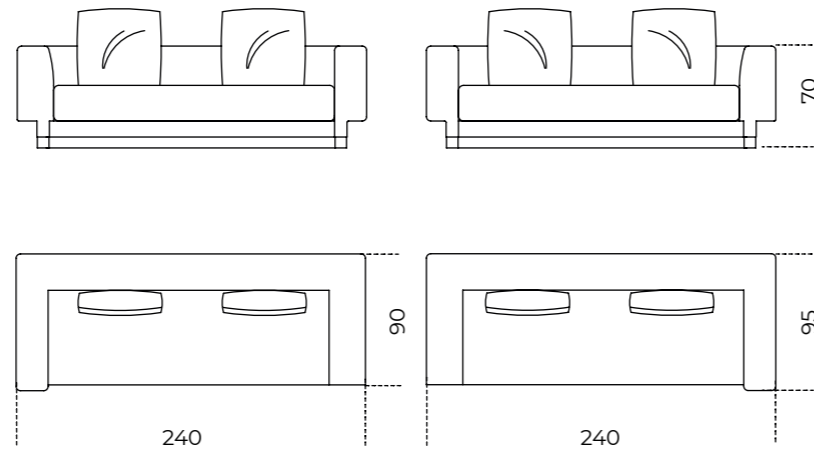

**ELS-TA280L/TA280R**

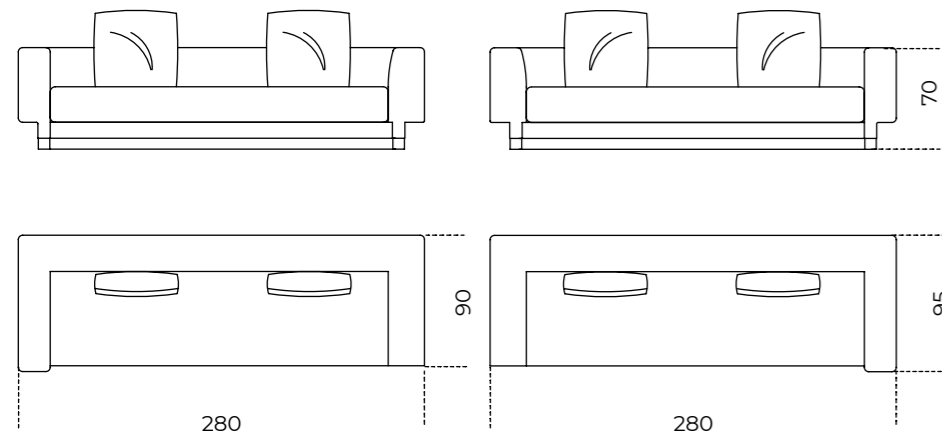

**ELS-CA200**

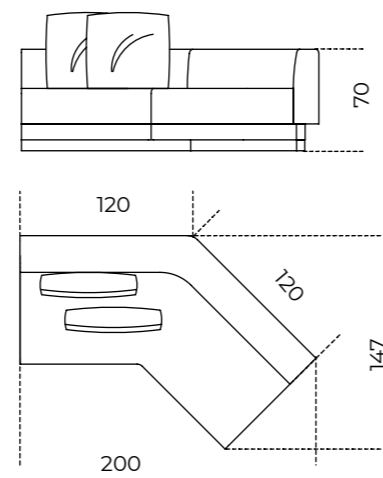

**ELS-C100**

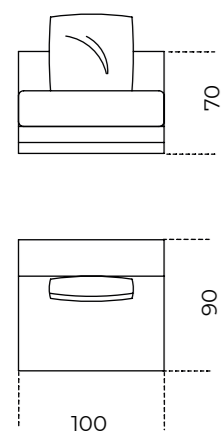

**ELS-C120**

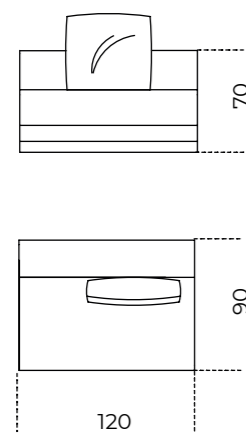

**ELS-C200**

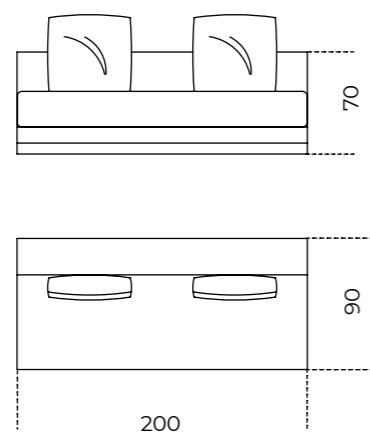

**ELS-C240**

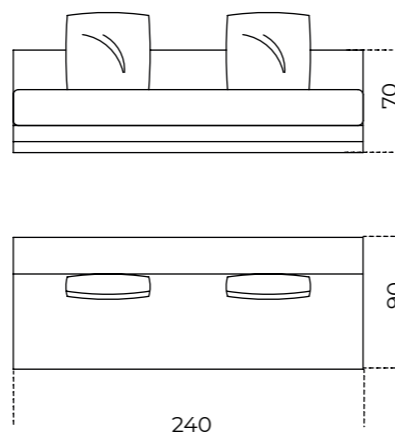

**Composizioni**  
Compositions

Product information / p.188

**Composizione 1 / Composition 1**

**400 x 96 x 69h**  
157½" x 38" x 27¼"h

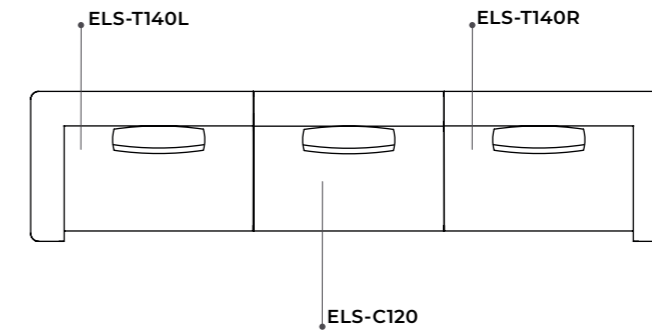

**Composta da**  
Composed by  
n.1 ELS-T140L  
n.1 ELS-C120  
n.1 ELS-T140R

**Composizione 2 / Composition 2**

**280 x 260 x 69h**  
110¼" x 102½" x 27¼"h

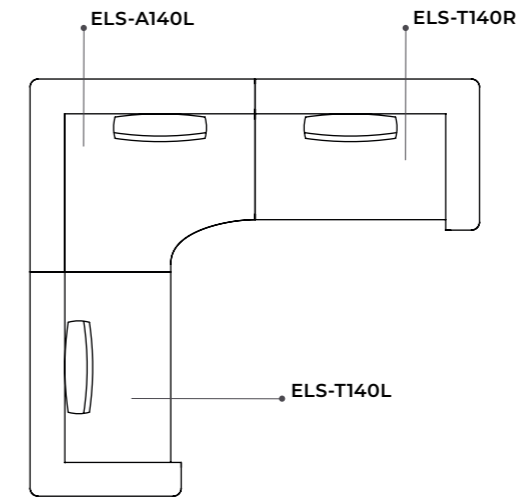

**Composta da**  
Composed by  
n.1 ELS-T140L  
n.1 ELS-A140L  
n.1 ELS-T140R

**Composizione 3 / Composition 3**

**360 x 280 x 69h**  
141¾" x 110¼" x 27¼"h

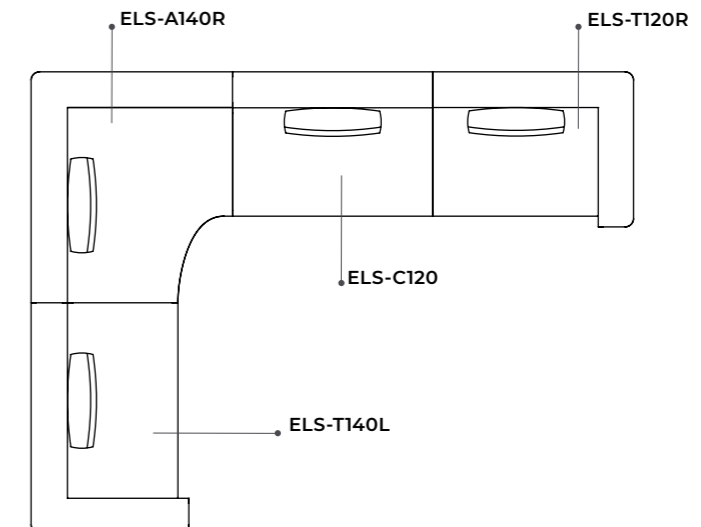

**Composta da**  
Composed by  
n.1 ELS-T140L  
n.1 ELS-A140R  
n.1 ELS-C120  
n.1 ELS-T120R



**Composizioni**  
Compositions

[Product information / p.188](#)

**Composizione 4 / Composition 4**

**356 x 164 x 69h**  
140<sup>3</sup>/<sub>4</sub>" x 64<sup>3</sup>/<sub>4</sub>" x 27<sup>1</sup>/<sub>4</sub>"h

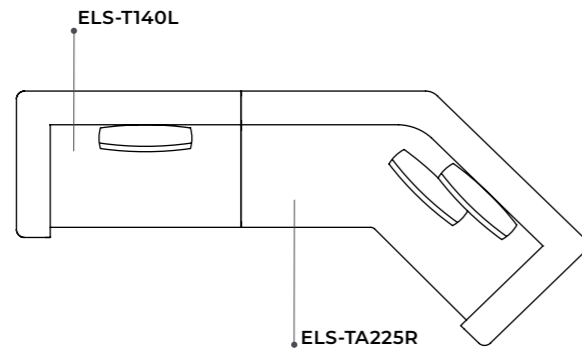

**Composta da**  
Composed by  
n.1 ELS-T140L  
n.1 ELS-TA225R

**Composizioni**  
Compositions

[Product information / p.188](#)

**Composizione 7 / Composition 7**

**230 x 280 x 69h**  
90<sup>3</sup>/<sub>4</sub>" x 110<sup>1</sup>/<sub>4</sub>" x 27<sup>1</sup>/<sub>4</sub>"h

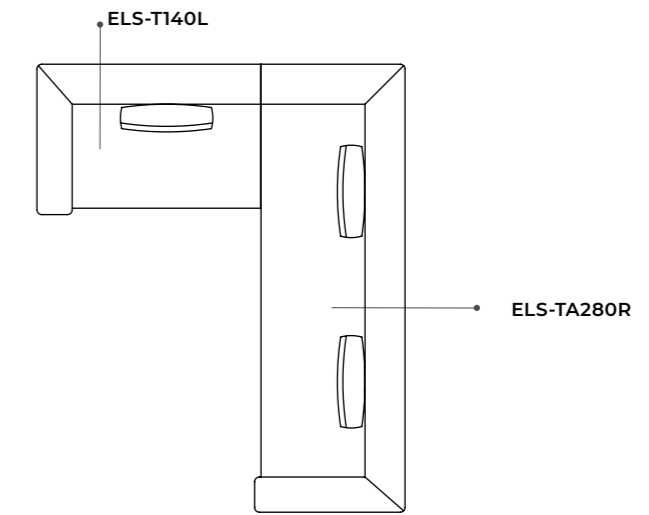

**Composta da**  
Composed by  
n.1 ELS-T140L  
n.1 ELS-TA280R

**Composizione 5 / Composition 5**

**475 x 185 x 69h**  
187<sup>1</sup>/<sub>2</sub>" x 73" x 27<sup>1</sup>/<sub>4</sub>"h

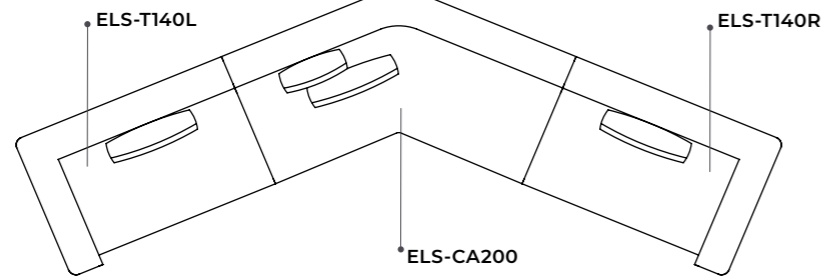

**Composta da**  
Composed by  
n.1 ELS-T140L  
n.1 ELS-CA200  
n.1 ELS-T140R

**Composizione 8 / Composition 8**

**350 x 240 x 69h**  
138" x 94<sup>1</sup>/<sub>2</sub>" x 27<sup>1</sup>/<sub>4</sub>"h

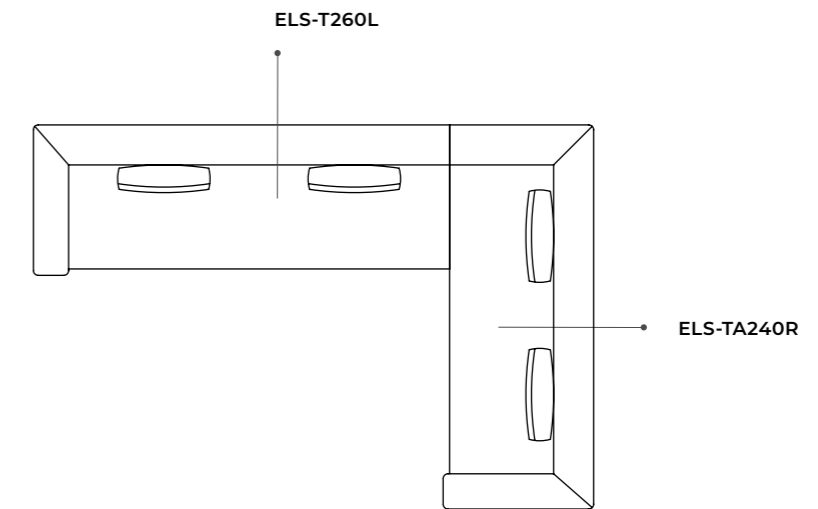

**Composta da**  
Composed by  
n.1 ELS-T260L  
n.1 ELS-TA240R

**Composizione 6 / Composition 6**

**430 x 164 x 69h**  
169<sup>1</sup>/<sub>2</sub>" x 64<sup>3</sup>/<sub>4</sub>" x 27<sup>1</sup>/<sub>4</sub>"h

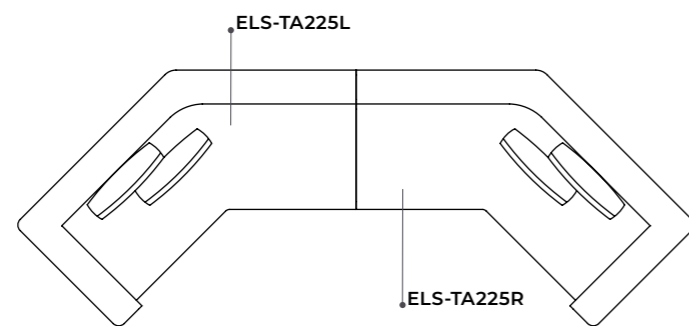

**Composta da**  
Composed by  
n.1 ELS-TA225L  
n.1 ELS-TA225R

**Composizione 9 / Composition 9**

**420 x 280 x 69h**  
165<sup>1</sup>/<sub>2</sub>" x 110<sup>1</sup>/<sub>4</sub>" x 27<sup>1</sup>/<sub>4</sub>"h

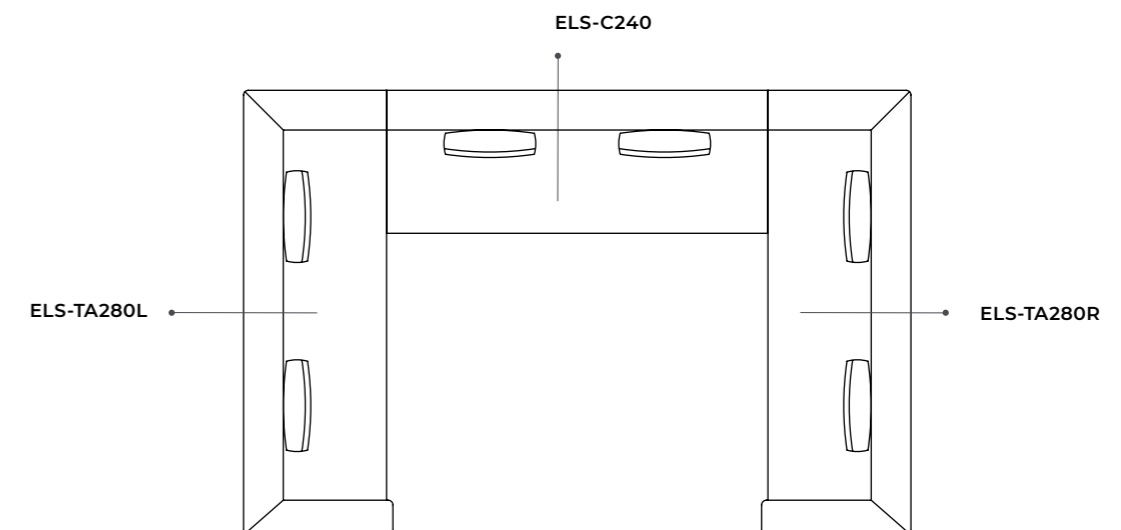

**Composta da**  
Composed by  
n.1 ELS-TA280L  
n.1 ELS-C240  
n.1 ELS-TA280R

**Fiona** | Massimo Castagna, 2018

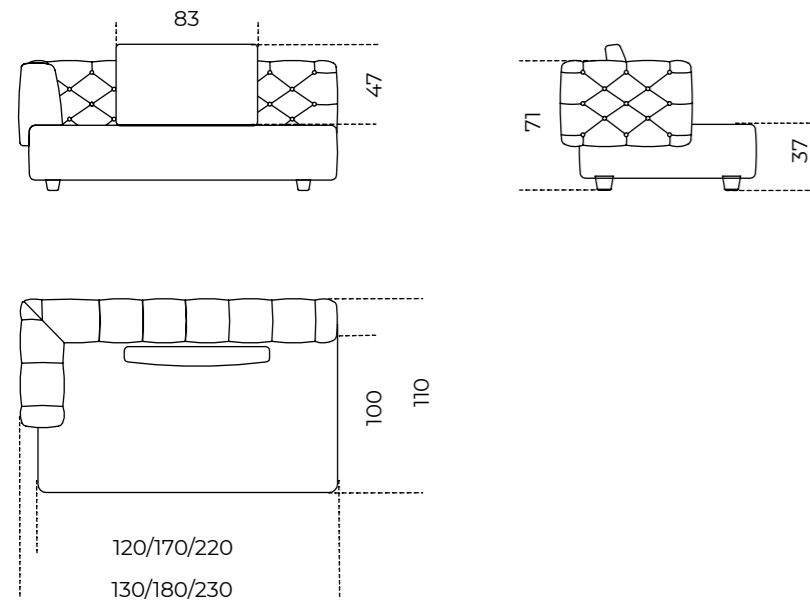

Product information / p.192



**Cuscino decorativo**  
Decorative cushion  
**40 x 40**  
15¾" x 15¾"  
**60 x 60**  
23¾" x 23¾"

**Fiona Soft** | Massimo Castagna, 2019

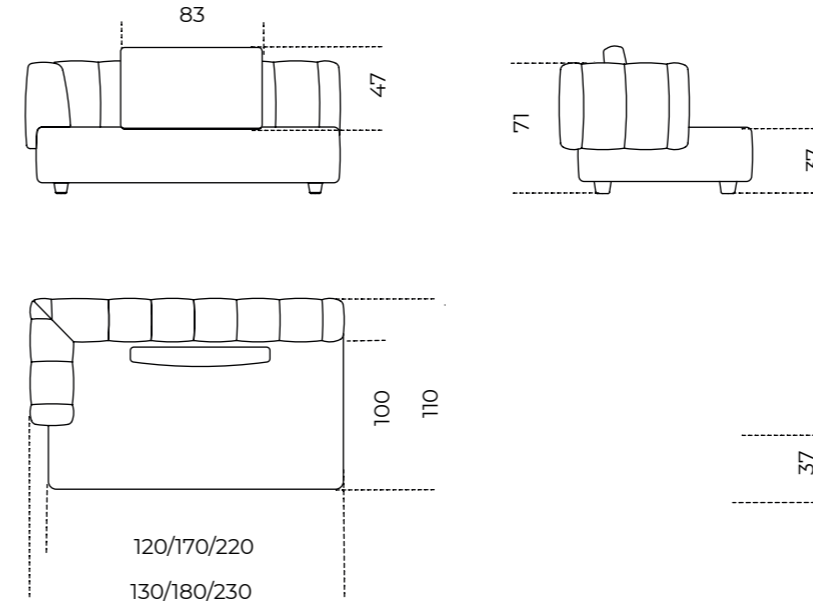

Product information / p.194

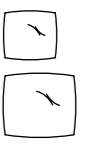

**Cuscino decorativo**  
Decorative cushion  
**40 x 40**  
15¾" x 15¾"  
**60 x 60**  
23¾" x 23¾"

**Moduli**  
Modules

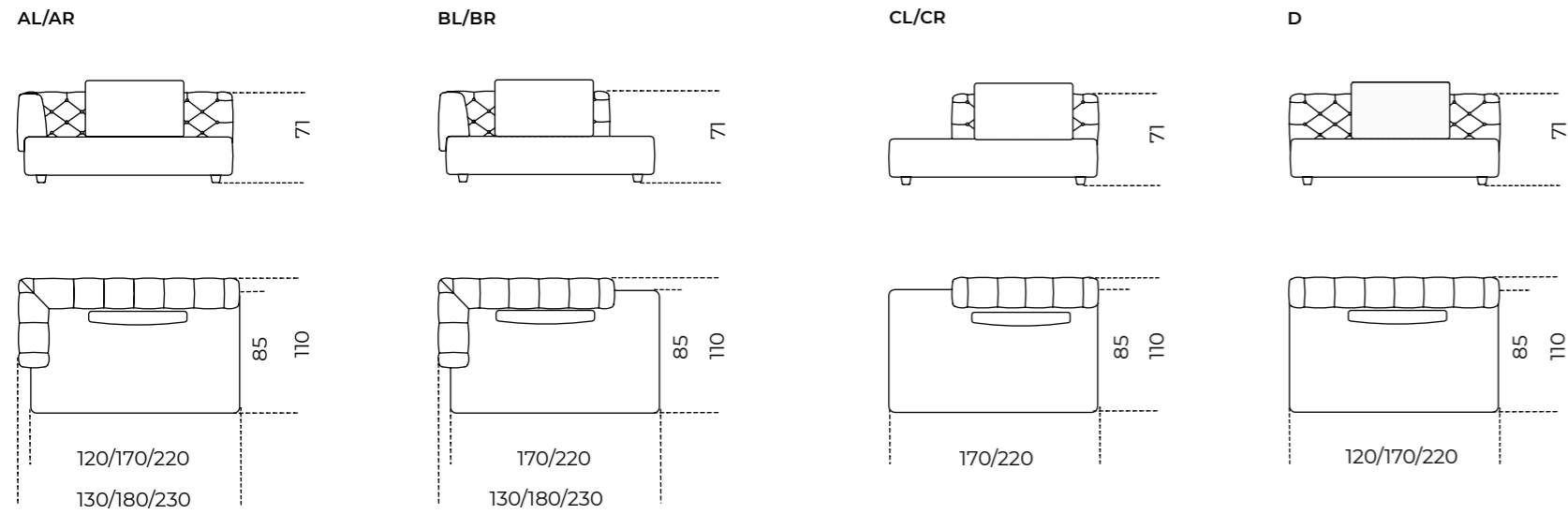

**Moduli**  
Modules

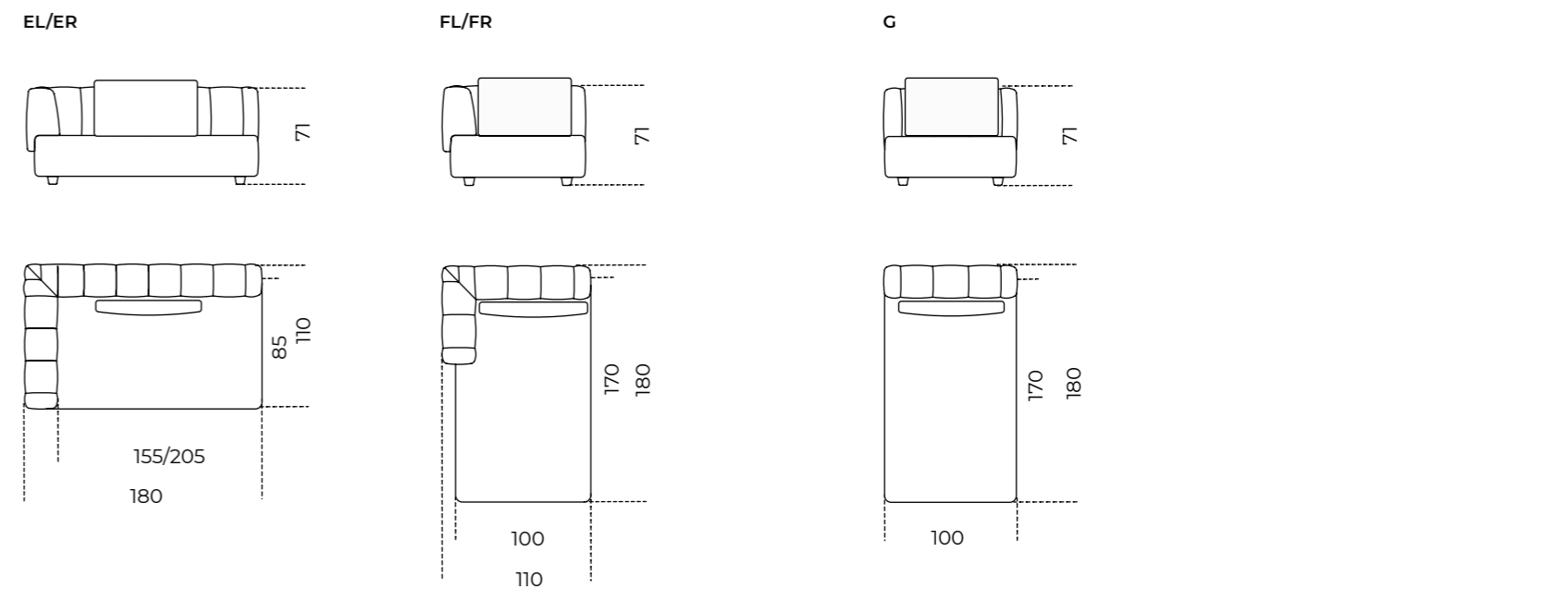
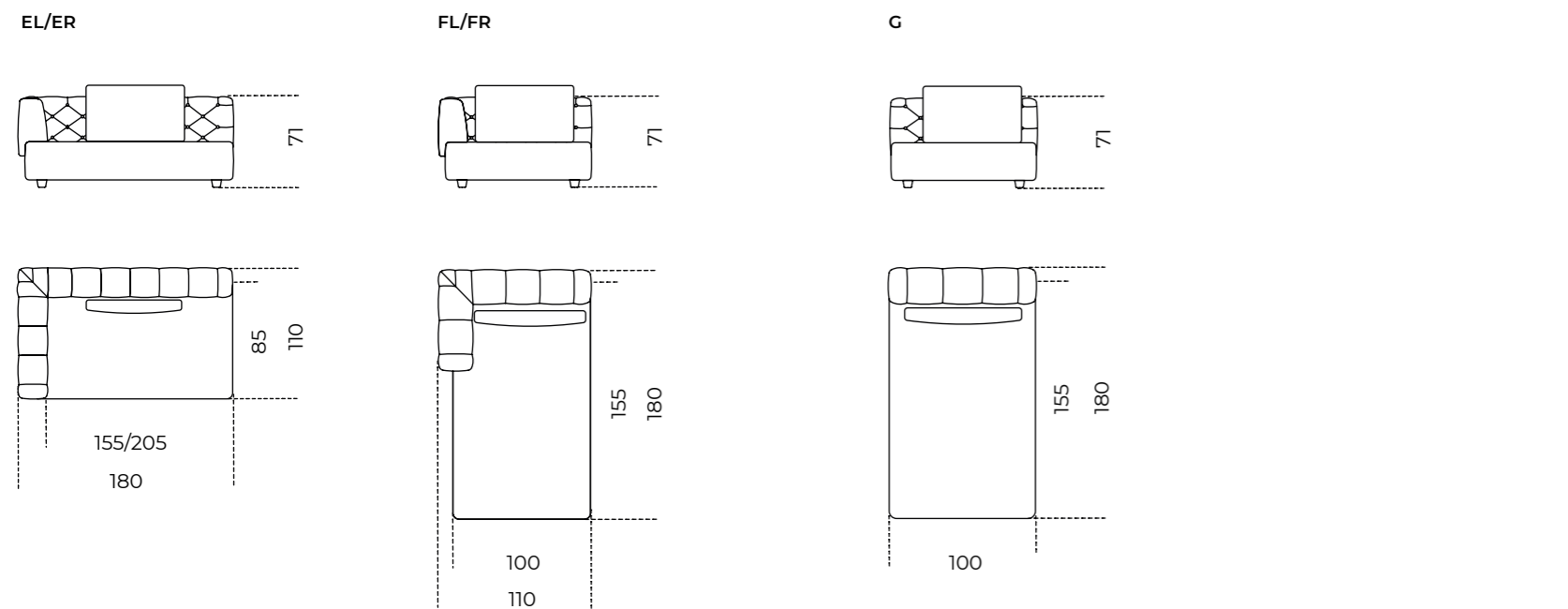
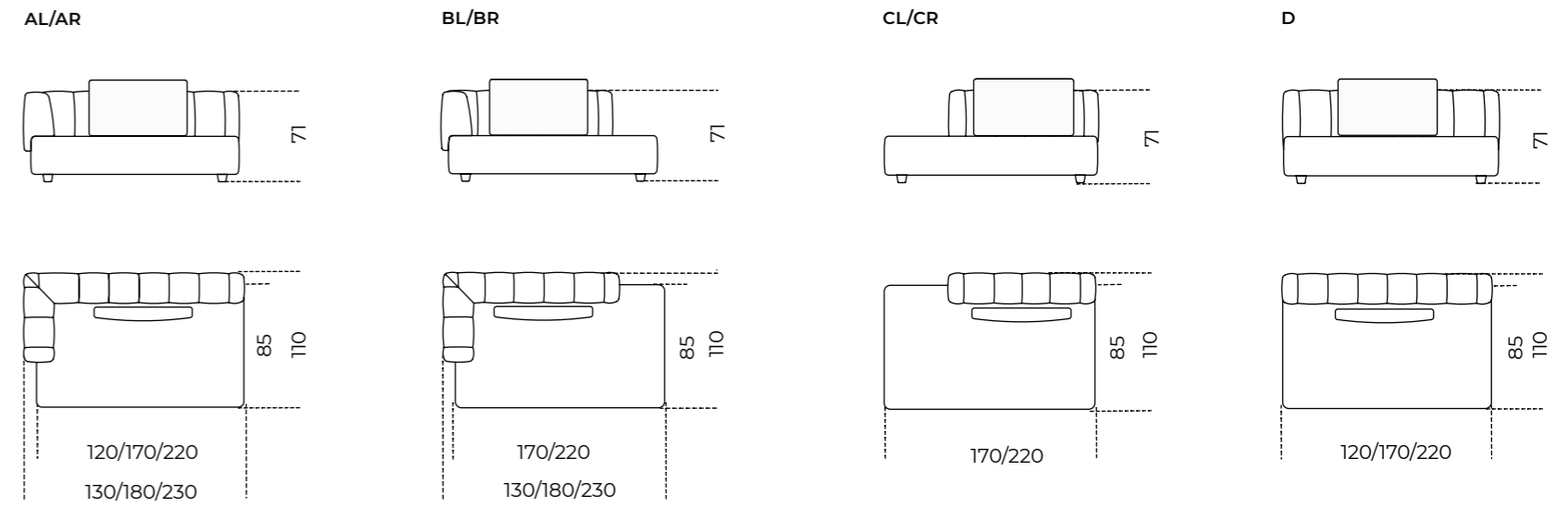

**First** | Massimo Castagna, 2014

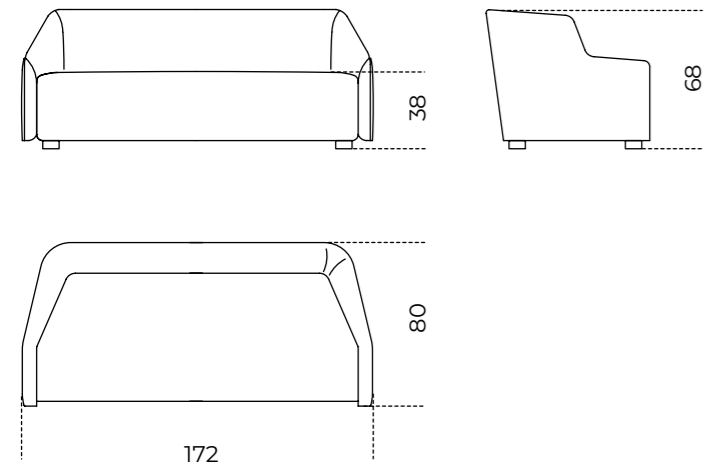

**Product information** / p. 196

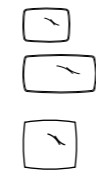

**Cuscino decorativo**  
Decorative cushion  
**35 x 25**  
14" x 10"  
**56 x 28**  
22¼" x 11¼"  
**40 x 40**  
15¾" x 15¾"

**First Modulare** | Massimo Castagna, 2015

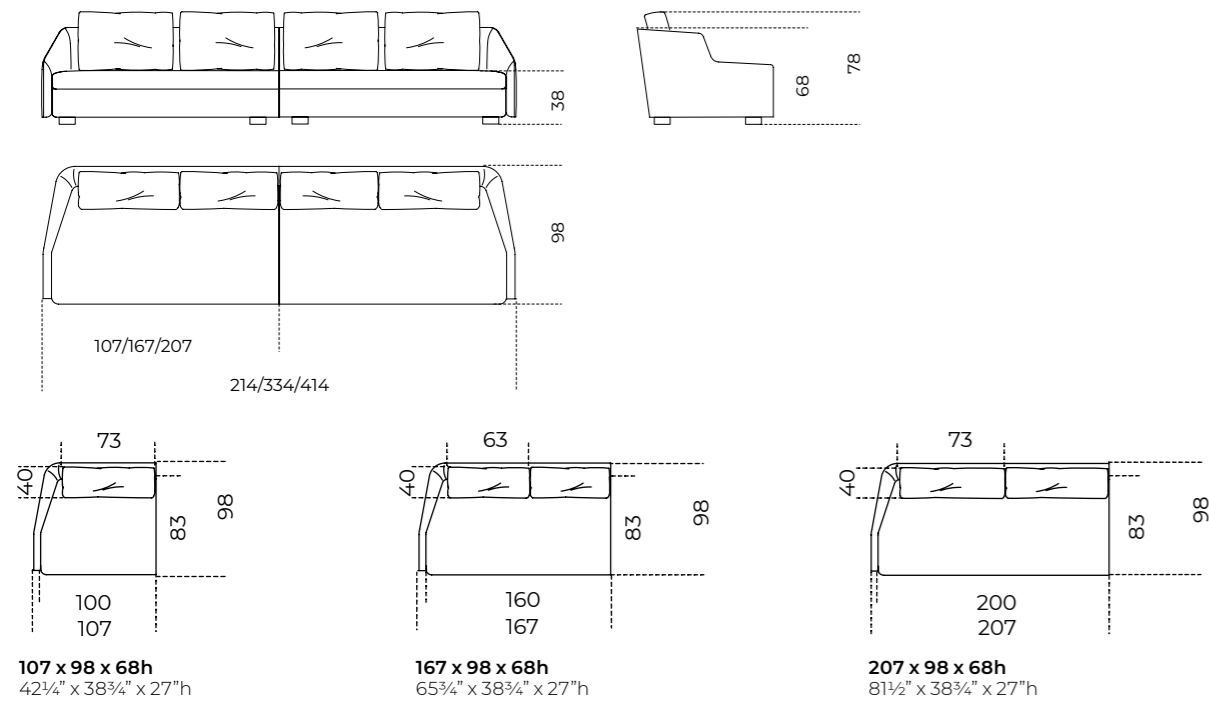

**Product information** / p. 198

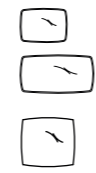

**Cuscino decorativo**  
Decorative cushion  
**35 x 25**  
14" x 10"  
**56 x 28**  
22¼" x 11¼"  
**40 x 40**  
15¾" x 15¾"

**First Poltrona & Pouf** | Massimo Castagna, 2015

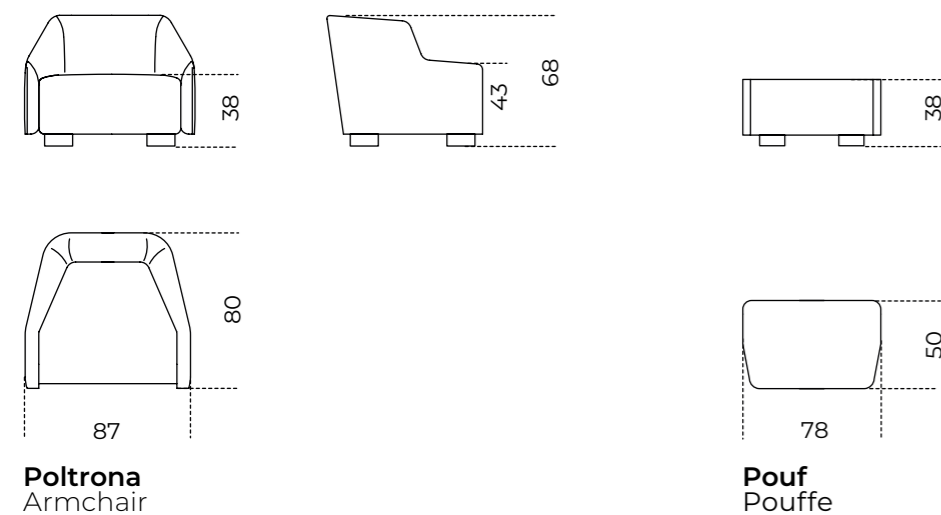

**Product information** / p. 200



**Cuscino decorativo**  
Decorative cushion  
**35 x 25**  
14" x 10"

**Lilas** | Dainelli Studio, 2021

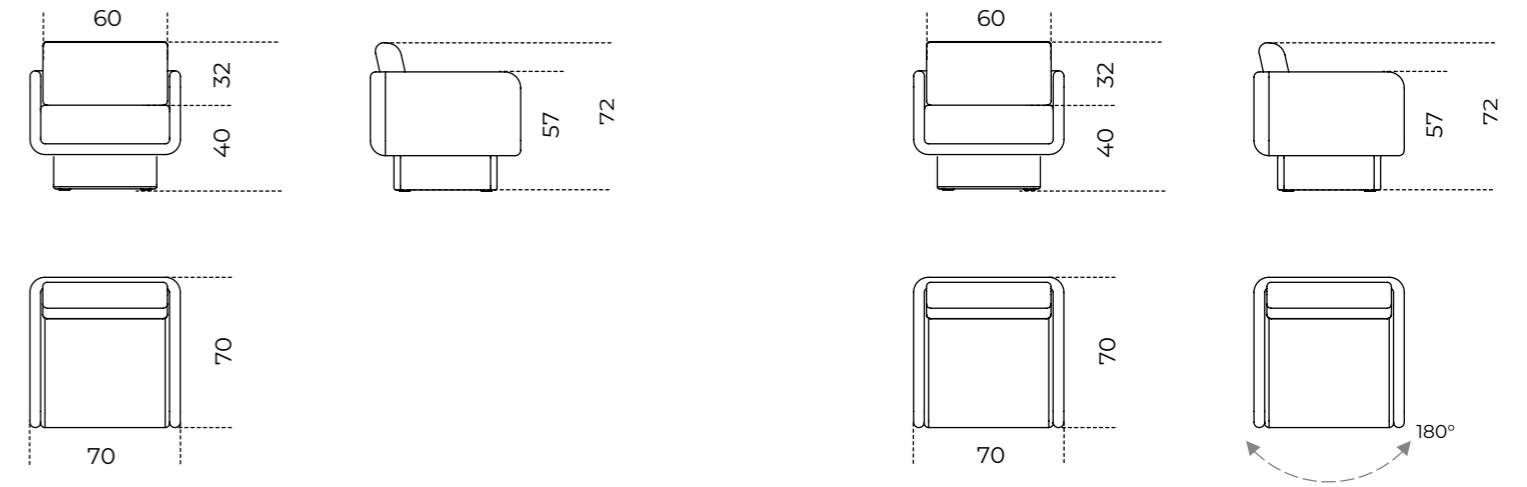

**Product information** / p. 202

**Versione girevole**

**Lilas Mosaïque** | Dainelli Studio, 2022

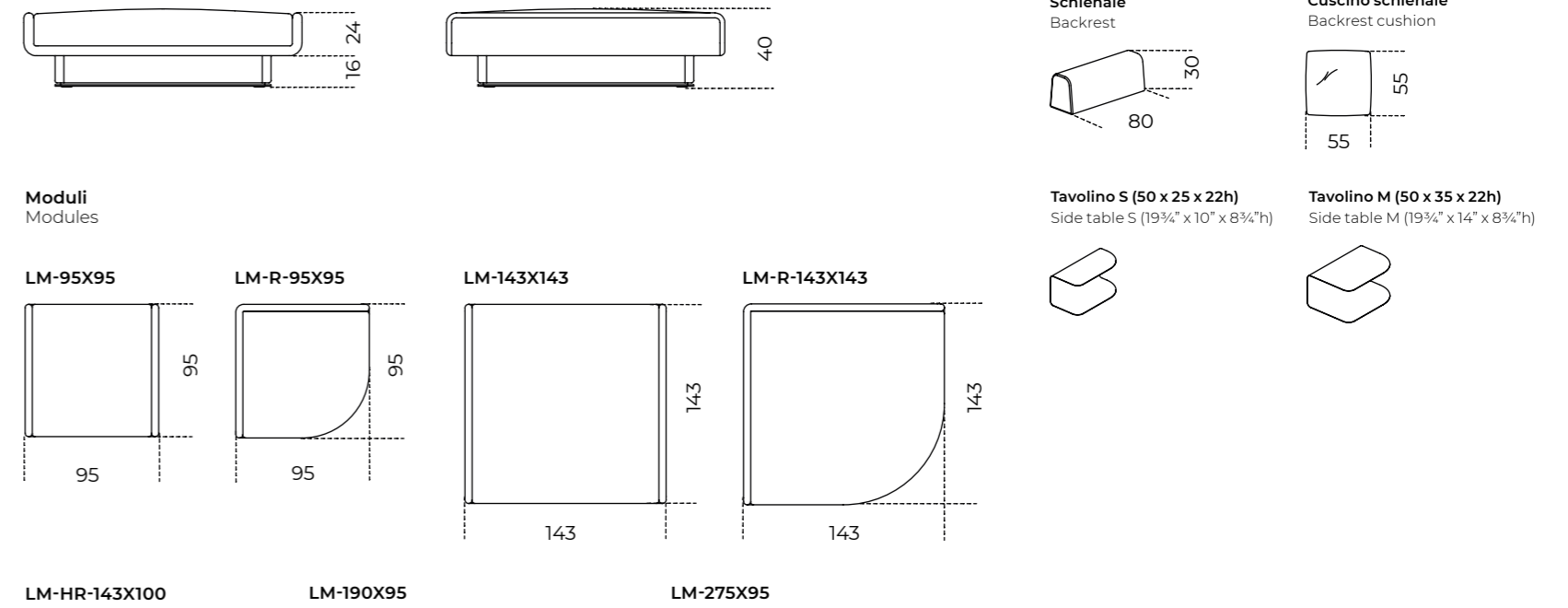

**Product information** / p. 204

**Moduli**  
Modules

**Posizione cuciture per versione in pelle/pelle scamosciata**  
Stitching position for leather/suede version

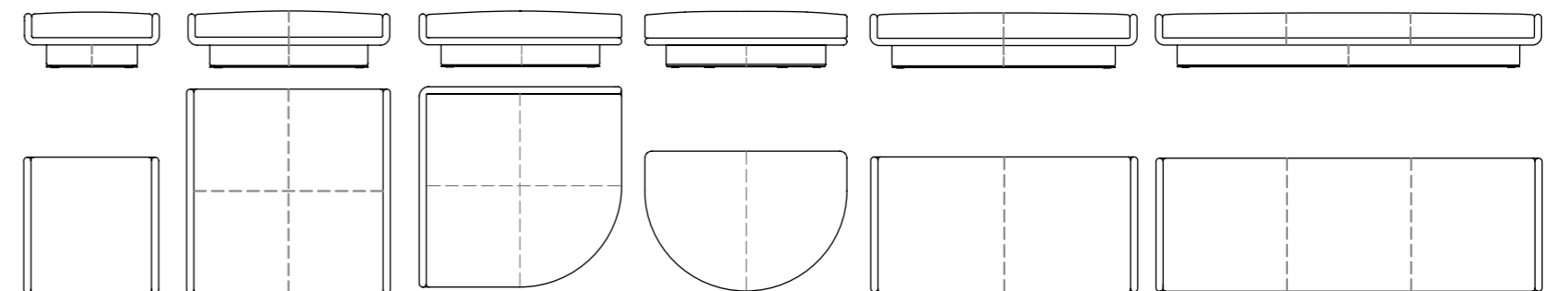

**Composizioni**  
Compositions

Product information / p. 204

**Composizione 1 / Composition 1**

**333 x 370 x 40h**  
131¼" x 145¾" x 15¾"h

**Composta da**  
Composed by

- n.1 LM-95X95
- n.1 LM-275X95
- n.1 LM-143X143
- n.1 LM-190X95
- n.4 Backrest
- n.5 Cushion 55X55
- n.1 Side table M 50X35X22
- n.1 Side table S 50X25X22

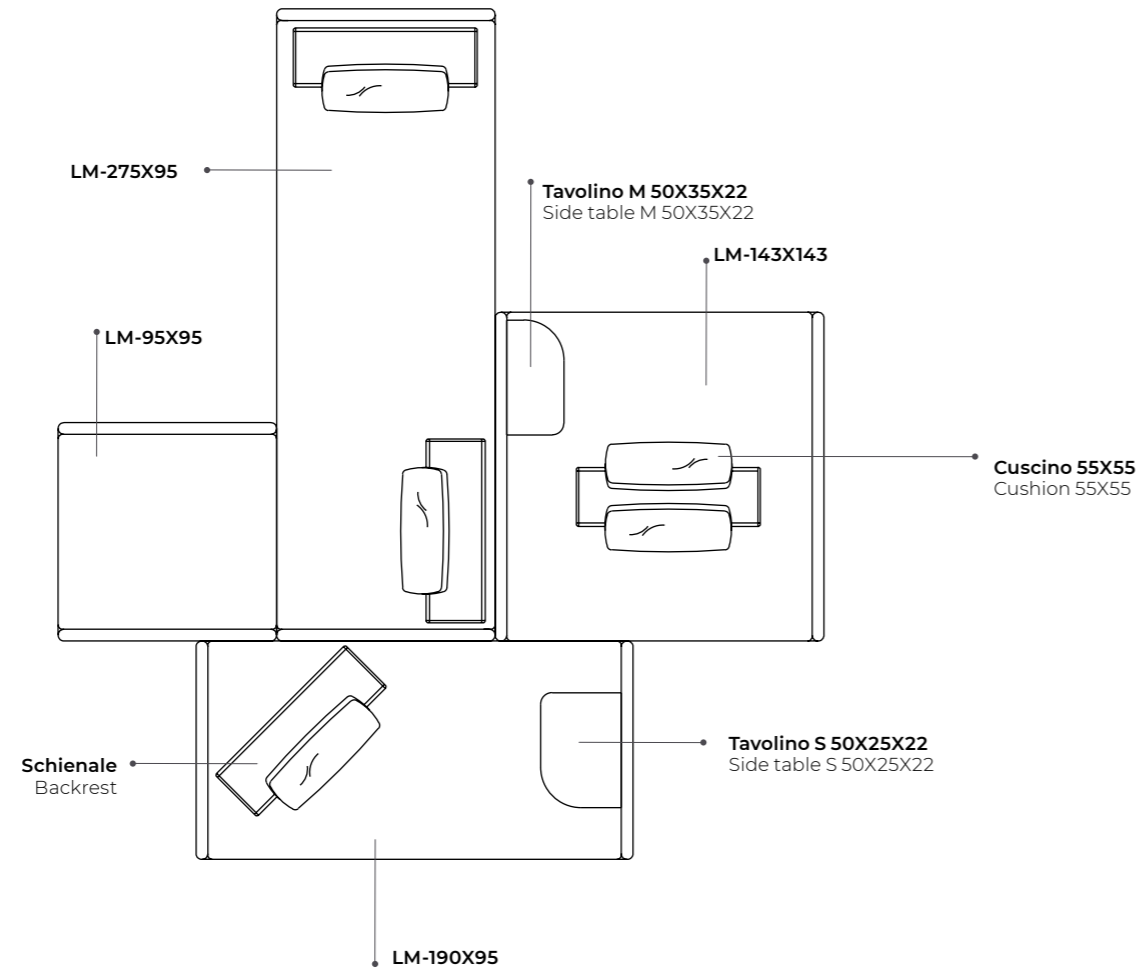

**Composizione 2 / Composition 2**

**333 x 286 x 40h**  
131¼" x 112¾" x 15¾"h

**Composta da**  
Composed by

- n.1 LM-95X95
- n.2 LM-143X143
- n.1 LM-190X95
- n.3 Backrest
- n.3 Cushion 55X55
- n.1 Side table M 50X35X22
- n.2 Side table S 50X25X22

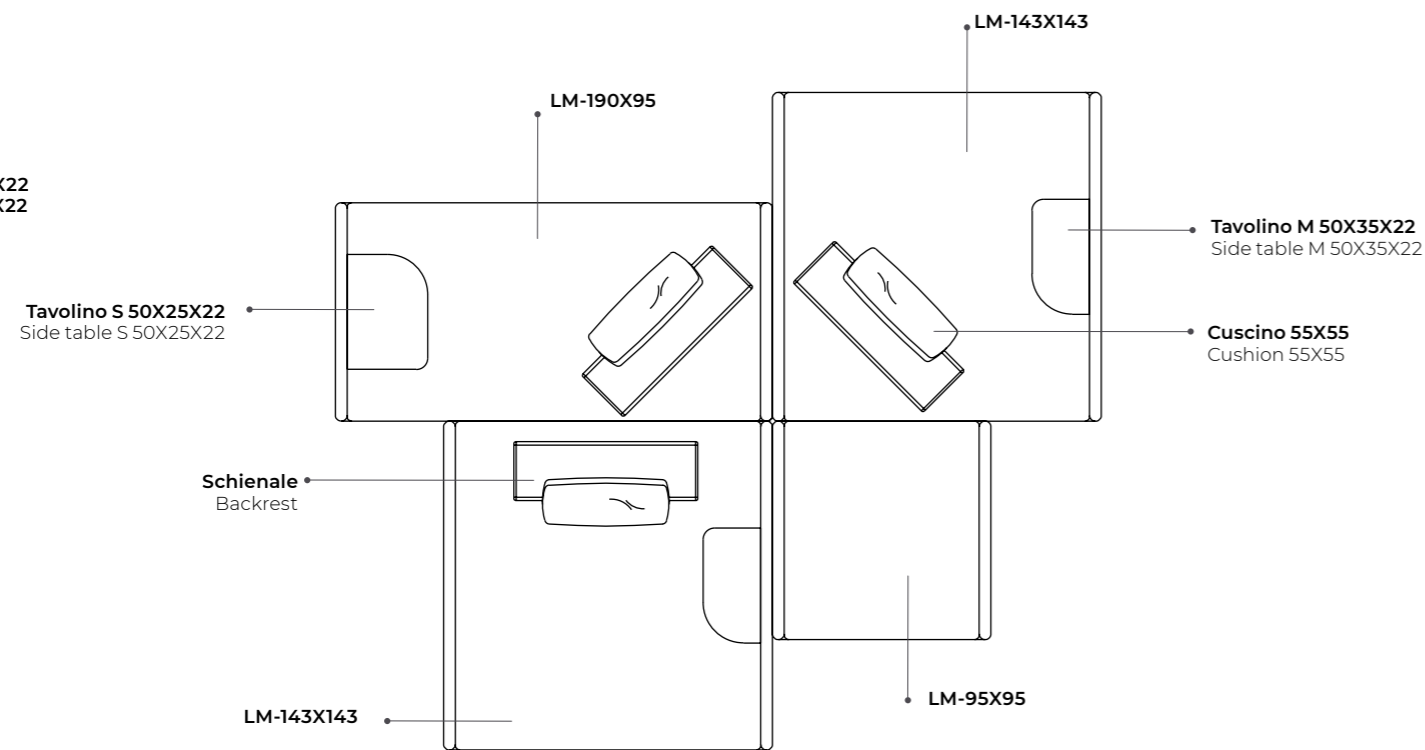

**Livre | Federica Biasi, 2020**

Product information / p. 206

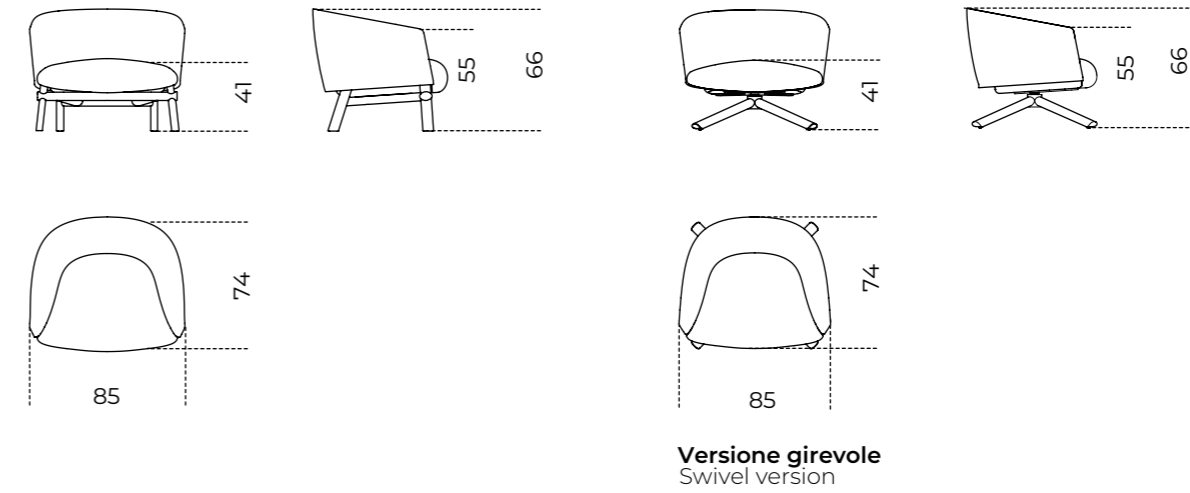

**Sophie | Federica Biasi, 2018**

Product information / p. 208

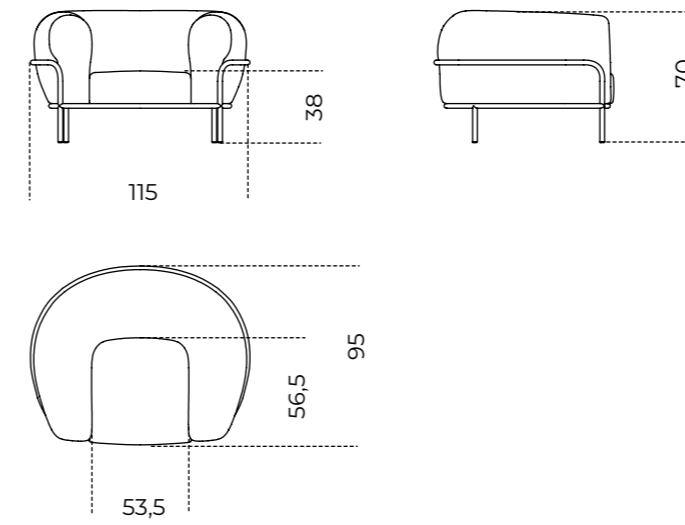

**Sophie Sofa | Federica Biasi, 2019**

Product information / p. 210

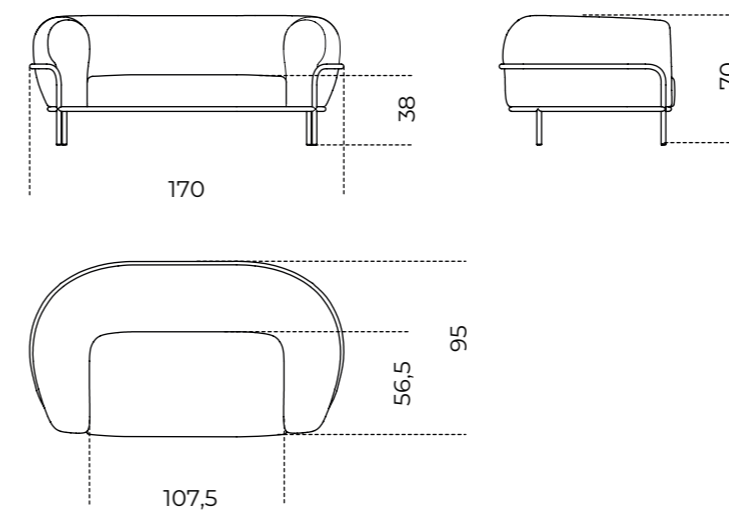

**Stami Lounge** | Studiopepe, 2023

Product information / p. 212

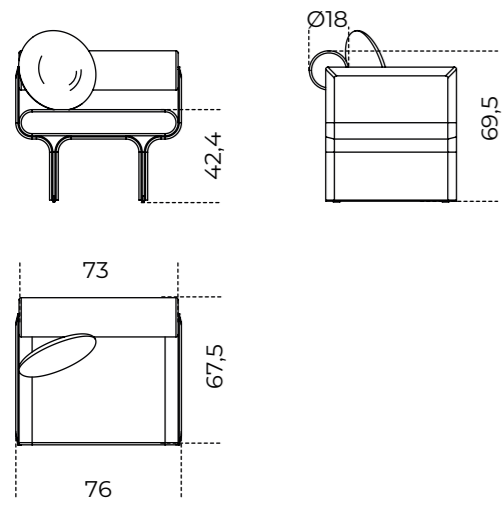

**Stami Loveseat** | Studiopepe, 2024

Product information / p. 214

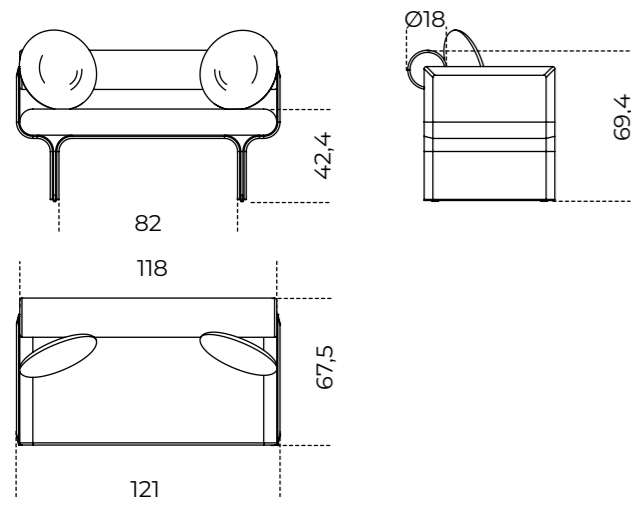

**Stami Sofa** | Studiopepe, 2024

Product information / p. 216

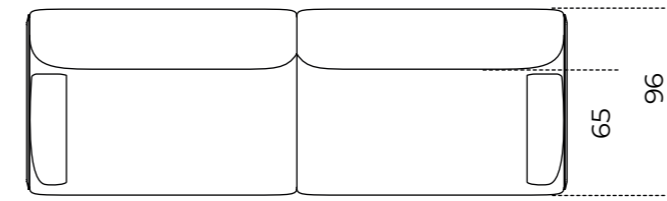
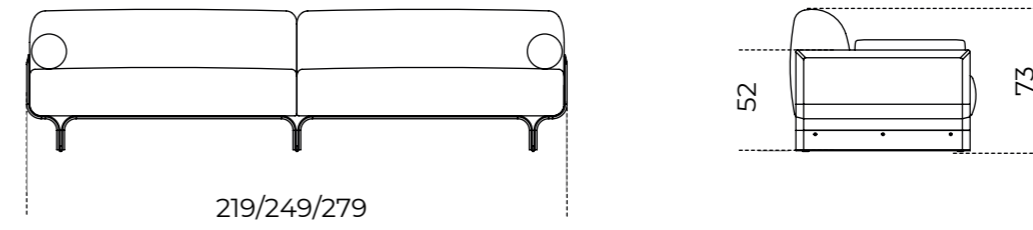

**Versione VIS A VIS**  
VIS a VIS version

**VIS L**

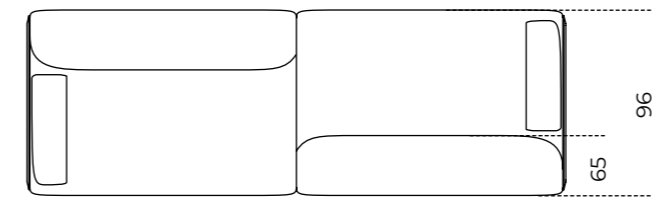
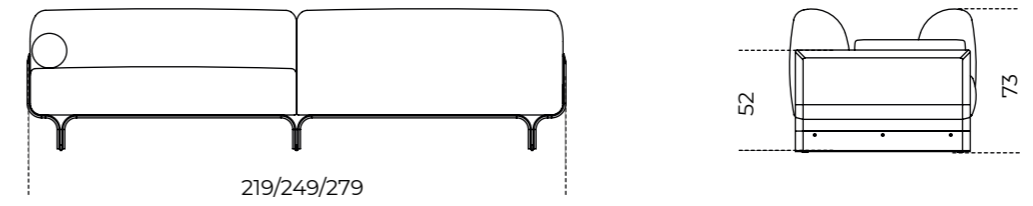

**VIS R**

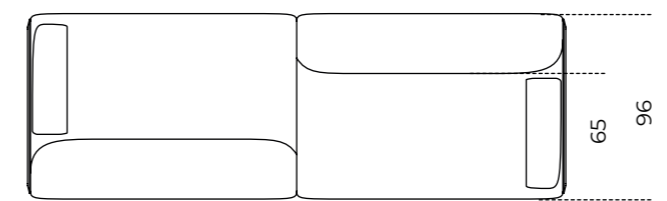
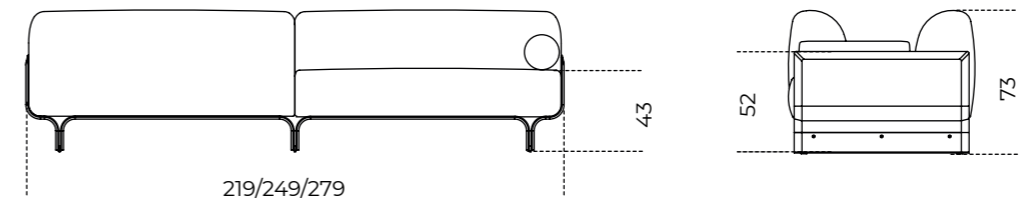

**Stami Sofa Plus** | Studiopepe, 2024

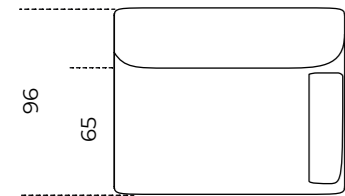
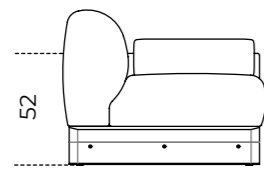
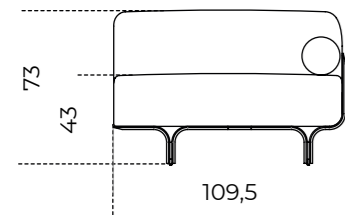

**Moduli**  
Modules

**Terminali**  
Terminal

**SPLUS-T110-L**

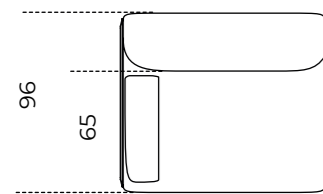
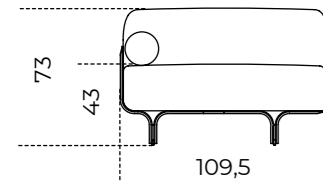

**SPLUS-T110-R**

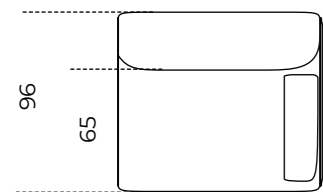
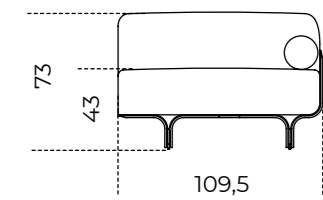

**SPLUS-T125-L**

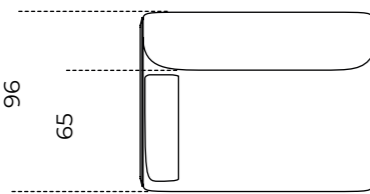
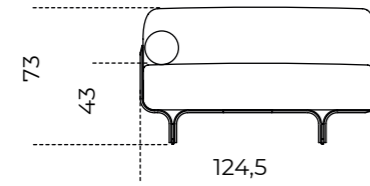

**SPLUS-T125-R**

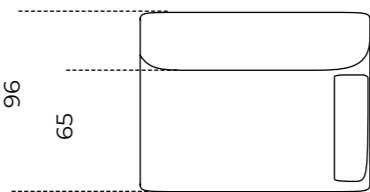
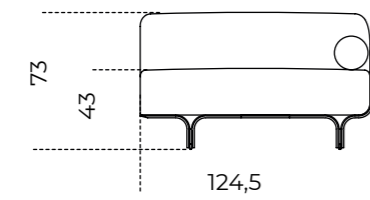

**SPLUS-T140-L**

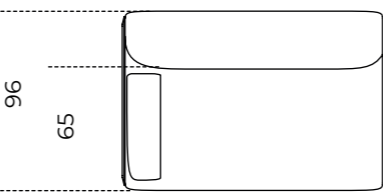
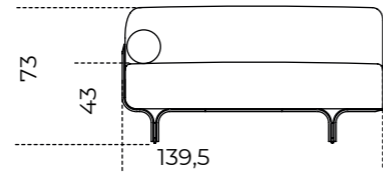

**SPLUS-T140-R**

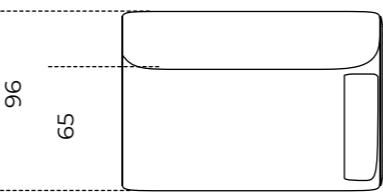
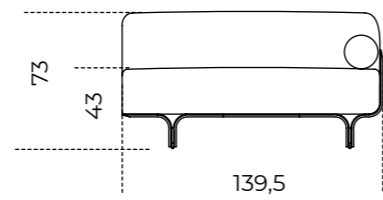

**Product information / p. 218**



**Cuscino decorativo**  
Decorative cushion  
40 x 40  
15 3/4" x 15 3/4"  
60 x 60  
23 3/4" x 23 3/4"

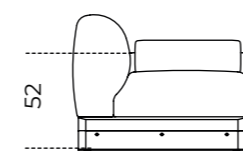
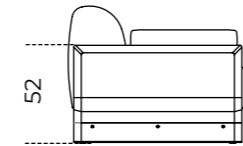

**Centrali**  
Central

**SPLUS-C108**

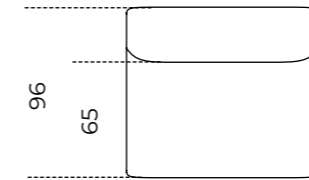
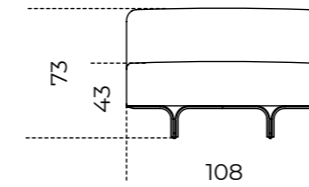

**SPLUS-C123**

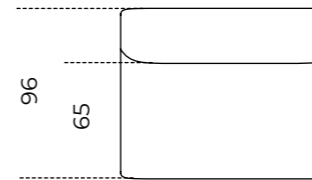
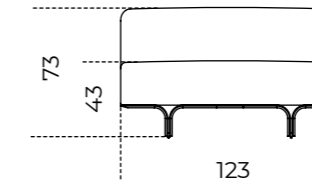

**SPLUS-C138**

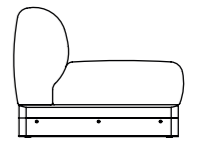
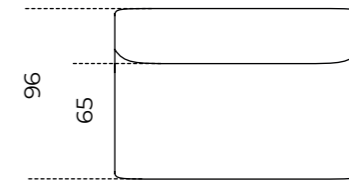
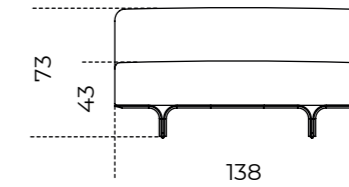

**Pouf**  
Pouffe

**SPLUS-POUF108**

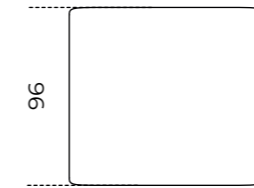
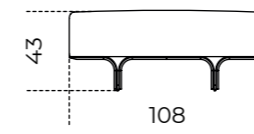

**SPLUS-POUF123**

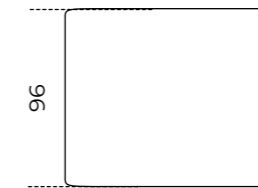
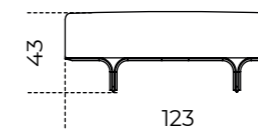

**SPLUS-POUF138**

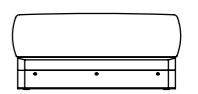
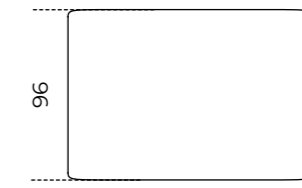
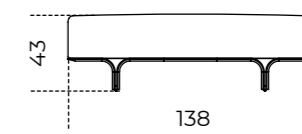

**Angolare**  
Angular

**SPLUS-A137**

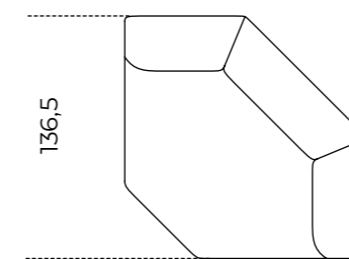
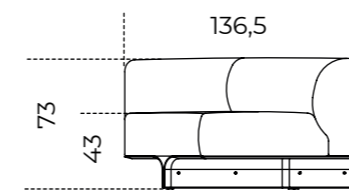

**Product information / p. 218**

**Composizioni**  
Compositions

[Product information / p. 218](#)

**Composizione 1 / Composition 1**

**400 x 96 x 73h**  
157½" x 38" x 28¾"h

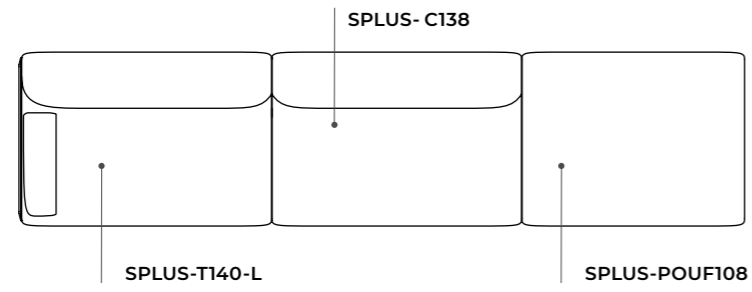

**Composta da**  
Composed by

n.1 SPLUS-T140-L  
n.1 SPLUS-C138  
n.1 SPLUS-POUF108

**Composizione 2 / Composition 2**

**415,5 x 357 x 73h**  
163½" x 140½" x 28¾"h

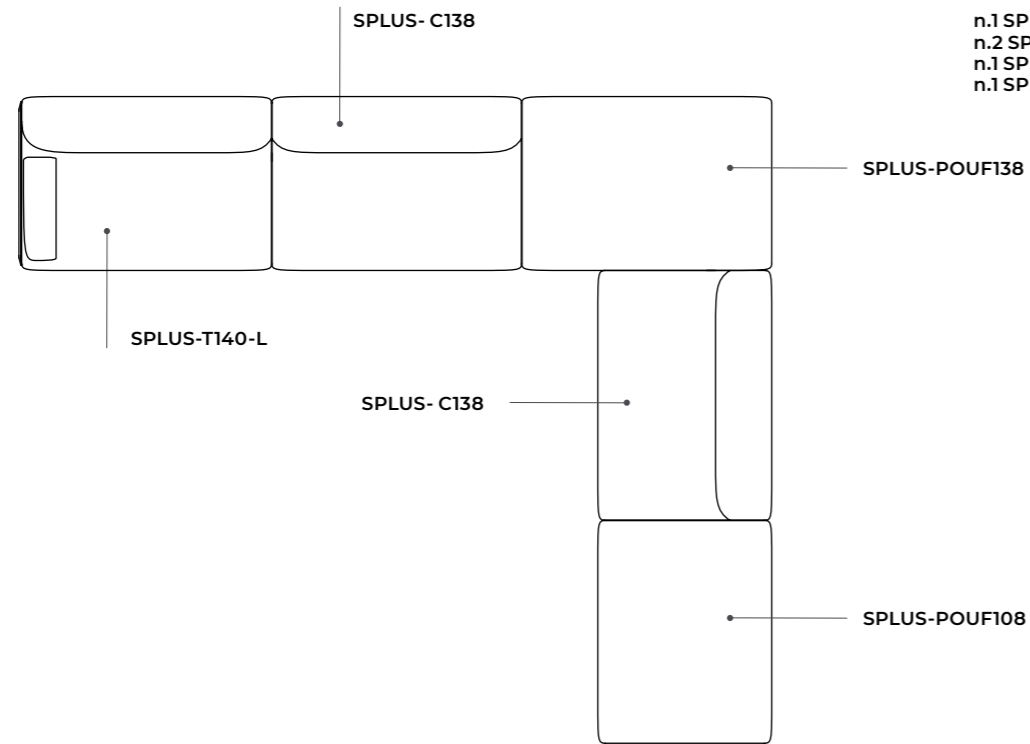

**Composta da**  
Composed by

n.1 SPLUS-T140-L  
n.2 SPLUS-C138  
n.1 SPLUS-POUF138  
n.1 SPLUS-POUF108

**Composizione 2 / Composition 2**

**413,5 x 397,5 x 73h**  
162¾" x 156½" x 28¾"h

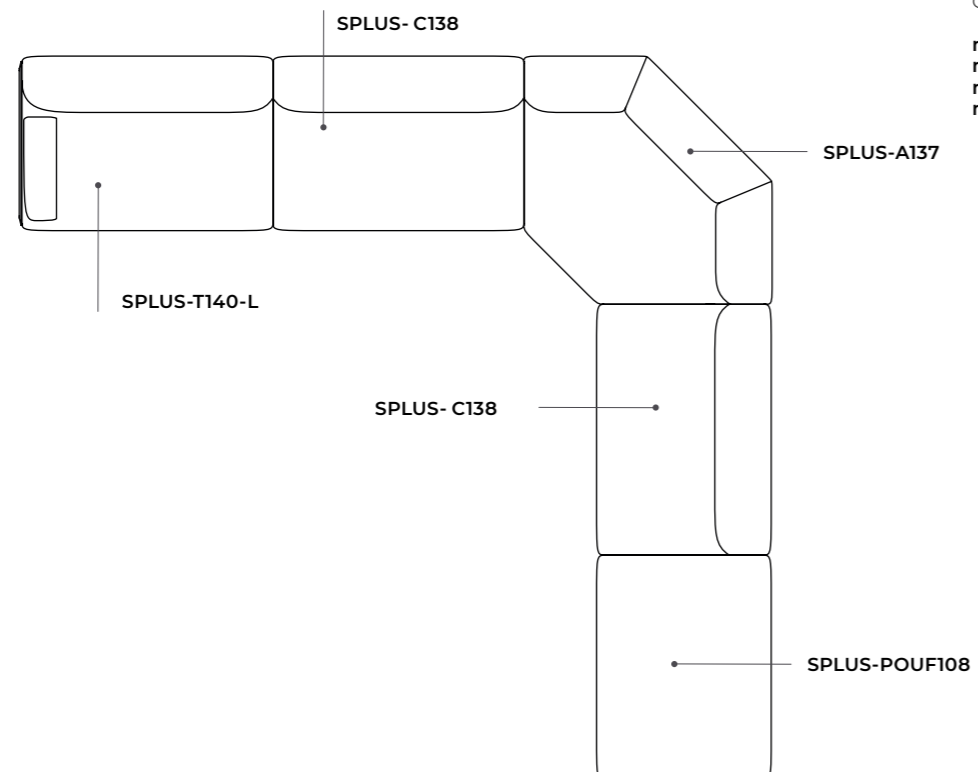

**Composta da**  
Composed by

n.1 SPLUS-T140-L  
n.2 SPLUS-C138  
n.1 SPLUS-A137  
n.1 SPLUS-POUF108

## 06 Tavolini /

### Coffee Tables

256	<b>1968</b>
258	<b>Chantal</b>
260	<b>Clemo</b>
264	<b>Connection</b>
266	<b>Cookies</b>
268	<b>Cookies Circle</b>
270	<b>Dama</b>
272	<b>Drummers</b>
274	<b>Fante</b>
276	<b>Faraday</b>
278	<b>George 1</b>
280	<b>George 2</b>
282	<b>Golden Moon</b>
284	<b>Gong</b>
286	<b>Haumea</b>
290	<b>Hide&amp;Seek Mini</b>
292	<b>Monete</b>
296	<b>Nori</b>
298	<b>Nox</b>
300	<b>Oto Mini</b>
302	<b>Prism Low</b>
304	<b>Raj 1</b>
306	<b>Raj 2</b>
308	<b>Raj 3</b>
310	<b>Raj 6</b>
312	<b>Re-verre</b>
316	<b>Selce</b>
318	<b>Sensei</b>
320	<b>Sir T 32/Sir T 32 C</b>
322	<b>T33</b>
324	<b>T35 R</b>
326	<b>T 35 Trio</b>
328	<b>Tetris</b>
330	<b>Twelve</b>
332	<b>Zen Black Low</b>
334	<b>Zen Low</b>
336	<b>Informazioni tecniche/ <a href="#">Technical informations</a></b>





▲ 1968

Piano marmo lucido naturale Verde Alpi / Base in ottone brunito a mano e frassino tinto nero a poro aperto  
Natural polished Verde Alpi marble top / Hand burnished brass and black open pore stained ash base

# 1968

Studio G&amp;R / 2019

Tavolino con piano in marmo lucido naturale Verde Alpi, Calacatta Vagli Oro o Nero Marquinia. Struttura in ottone brunito a mano e parti in frassino tinto nero a poro aperto. Sconsigliato posizionamento su tappeto.

## NOTE TECNICHE SUI MATERIALI

**MARMO** | Il marmo è un materiale naturale di origine sedimentaria che può presentare particolarità come venature, lievi irregolarità superficiali, colorazioni differenti e cristallizzazioni. Queste peculiarità sono da attribuirsi alla naturalezza del materiale e non sono da considerarsi difetti ma caratteristiche tipiche del marmo. Ogni prodotto risulterà unico, esclusivo e non replicabile.

I nostri marmi vengono trattati con un prodotto idrorepellente che permette una maggiore protezione della superficie stessa, aumentando l'impermeabilità. Questo trattamento non esclude la vulnerabilità del marmo alle sostanze acide.

**OTTONE BRUNITO A MANO** | L'ottone brunito a mano è ottenuto da un processo di ossidazione naturale eseguito manualmente. Il risultato di questa lavorazione è un prodotto che può presentare macchie e variazioni di colore che non sono da considerarsi imperfezioni ma caratteristiche che conferiscono ad ogni pezzo una particolare unicità, rendendolo esclusivo.

! Sconsigliato posizionamento su tappeto.

Coffee table with natural polished Verde Alpi, Calacatta Vagli Oro or Nero Marquinia marble top. Hand burnished brass structure with black open pore stained ash parts. Not recommended for positioning on carpet.

## TECHNICAL INFORMATION ON THE MATERIALS

**MARBLE** | The marble is a natural material of sedimentary origin that can present particularities such as veins, slight surface irregularities, different colors and crystallizations. These peculiarities are to be attributed to the naturalness of the material and are not to be considered defects but typical characteristics of marble. Each product will be unique, exclusive and non-replicable.

Our marbles are treated with water-repellent products which affords greater protection to the surface of the marble, improving its impermeability. This treatment doesn't exclude the vulnerability of the marble to acid substances.

**HAND BURNISHED BRASS** | The hand burnished brass is the consequence of hand-made process of natural oxidation. The result of this processing is a product that may show marks and colour variations. These differences are inevitable and should not be considered imperfections but evidence of the hand-crafted process. They enhance the beauty and distinctiveness of a unique piece.

! Not recommended for positioning on carpet.



**Cm**  
Ø49 x 45  
Ø49 x 50

**Inches**  
Ø19½" x 17¾"  
Ø19½" x 19¾"

[For technical drawing / p. 340](#)

[Pricelist 2023 / p. 120](#)  
[Homescapes, sense of materials / p. 32](#)  
[Homescapes, embracing beauty / p. 25](#)  
[Homescapes, gentle attitude / pp. 92, 93](#)

## PIANO/TOP



Marmo lucido naturale  
Calacatta Vagli Oro  
Natural polished  
Calacatta Vagli Oro marble



Marmo lucido naturale  
Verde Alpi  
Natural polished  
Verde Alpi marble



Marmo lucido naturale  
Nero Marquinia  
Natural polished  
Nero Marquinia marble

## STRUTTURA/STRUCTURE

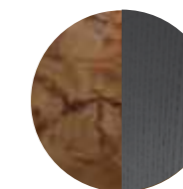

Ottone brunito a mano/  
Frassino tinto nero a poro aperto  
Hand burnished brass/  
Black open pore stained ash



▲ CHANTAL  
Piano e struttura in alluminio spazzolato a mano laccato opaco "Bordeaux Etruria"  
"Bordeaux Etruria" hand brushed aluminium opaque lacquered top and structure

# Chantal

Studio G&R / 2013

Tavolino con piano e struttura in alluminio spazzolato a mano anodizzato nero. Disponibile versione in alluminio spazzolato a mano laccato opaco nei colori "Bianco Camargue", "Sabbia del Nilo", "Rosa Jaipur", "Rosso Persia", "Bordeaux Etruria", "Verde Provenza", "Blu Pacifico", "Grigio Londra" e "Nero Giza".

Coffee table with top and structure in black hand brushed anodized aluminium. Also available version in hand brushed aluminium opaque lacquered in the colours "Bianco Camargue", "Sabbia del Nilo", "Rosa Jaipur", "Rosso Persia", "Bordeaux Etruria", "Verde Provenza", "Blu Pacifico", "Grigio Londra" and "Nero Giza".



Cm	Inches
40 x 40 x 50	15¾" x 15¾" x 19¾"
40 x 40 x 45	15¾" x 15¾" x 17¾"
60 x 60 x 45	23¾" x 23¾" x 17¾"
60 x 60 x 30	23¾" x 23¾" x 12"
60 x 60 x 25	23¾" x 23¾" x 10"

For technical drawing / p. 340

Pricelist 2023 / p. 121

## PIANO E STRUTTURA/TOP AND STRUCTURE



Alluminio spazzolato nero  
Black brushed aluminium



Alluminio spazzolato laccato opaco  
"Bianco Camargue"  
"Bianco Camargue" aluminium opaque lacquered



Alluminio spazzolato laccato opaco  
"Sabbia del Nilo"  
"Sabbia del Nilo" aluminium opaque lacquered



Alluminio spazzolato laccato opaco  
"Rosa Jaipur"  
"Rosa Jaipur" aluminium opaque lacquered



Alluminio spazzolato laccato opaco  
"Rosso Persia"  
"Rosso Persia" aluminium opaque lacquered



Alluminio spazzolato laccato opaco  
"Bordeaux Etruria"  
"Bordeaux Etruria" aluminium opaque lacquered

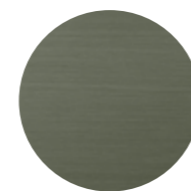

Alluminio spazzolato laccato opaco  
"Verde Provenza"  
"Verde Provenza" aluminium opaque lacquered



Alluminio spazzolato laccato opaco  
"Blu Pacifico"  
"Blu Pacifico" aluminium opaque lacquered

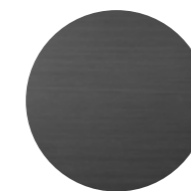

Alluminio spazzolato laccato opaco  
"Grigio Londra"  
"Grigio Londra" aluminium opaque lacquered



Alluminio spazzolato laccato opaco  
"Nero Giza"  
"Nero Giza" aluminium opaque lacquered

# Clemo

Massimo Castagna / 2021

Tavolino in Ceppo di Gré® spazzolato, con dettagli in metallo brunito a mano "dark". Disponibile anche in marmo Calacatta Vagli Oro lucido naturale, Bianco Carrara Gioia lucido naturale, Fior di Pesco spazzolato oppure Travertino Romano spazzolato naturale (non resinato).

Coffee table in brushed Ceppo di Gré® with "dark" hand burnished metal details. Also available in natural polished Calacatta Vagli Oro, natural polished Bianco Carrara Gioia marble, Fior di Pesco brushed marble or natural brushed Travertino Romano (not treated with resin).

## NOTE TECNICHE SUI MATERIALI

**CEPPO DI GRÉ® - MARMO** | Il marmo è un materiale naturale di origine sedimentaria che può presentare particolarità come venature, lievi irregolarità superficiali, colorazioni differenti e cristallizzazioni. Queste peculiarità sono da attribuirsi alla naturalezza del materiale e non sono da considerarsi difetti ma caratteristiche tipiche del marmo. Ogni prodotto risulterà unico, esclusivo e non replicabile. I nostri marmi vengono trattati con un prodotto idrorepellente che permette una maggiore protezione della superficie stessa, aumentando l'impermeabilità. Questo trattamento non esclude la vulnerabilità del marmo alle sostanze acide.

## TECHNICAL INFORMATION ON THE MATERIALS

**CEPPO DI GRÉ® - MARBLE** | The marble is a natural material of sedimentary origin that can present particularities such as veins, slight surface irregularities, different colors and crystallizations. These peculiarities are to be attributed to the naturalness of the material and are not to be considered defects but typical characteristics of marble. Each product will be unique, exclusive and non-replicable. Our marbles are treated with water-repellent products which affords greater protection to the surface of the marble, improving its impermeability. This treatment doesn't exclude the vulnerability of the marble to acid substances.



**Cm**  
Ø 49 x 40  
Ø 90 x 31,5  
Ø 120 x 28

**Inches**  
19½" x 15¾"  
35½" x 12½"  
47¼" x 11¼"

[For technical drawing / p. 340](#)

[Pricelist 2023 / p. 122](#)  
[Homescapes, intimate portraits / pp. 17, 23, 65, 71](#)  
[Homescapes, gentle attitude / pp. 22, 25, 92, 93](#)

## STRUTTURA/STRUCTURE



**CLEMO**  
Ceppo di Gré® spazzolato  
Brushed Ceppo di Gré®

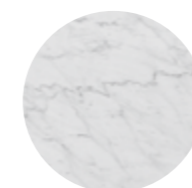

**Marmo lucido naturale**  
Bianco Carrara Gioia  
Natural polished  
Bianco Carrara Gioia marble



**Marmo lucido naturale**  
Calacatta Vagli Oro  
Natural polished Calacatta  
Vagli Oro marble



**Marmo spazzolato**  
Fior di Pesco  
Fior di Pesco brushed  
marble



**Travertino Romano**  
spazzolato naturale  
Natural brushed  
Travertino Romano

## DETTAGLI/DETAILS



**Metallo brunito a mano**  
"dark"  
"Dark" hand burnished  
metal



• CLEMO  
Marmo lucido naturale Bianco Carrara Gioia  
Natural polished Bianco Carrara Gioia marble



• CLEMO  
Marmo lucido naturale Calacatta Vagli Oro  
Natural polished Calacatta Vagli Oro marble



• CLEMO  
Marmo lucido naturale Bianco Carrara Gioia  
Natural polished Bianco Carrara Gioia marble



# Connection

Massimo Castagna / 2013

Tavolino in cristallo extralight. Struttura in ottone brunito a mano. L'ottone risulta naturalmente macchiato e disomogeneo. Questa lavorazione artigianale conferisce ad ogni pezzo una particolare unicità, rendendolo esclusivo.

Coffee table with extralight glass. Structure in hand burnished brass. The hand burnished brass finish looks naturally spotted and irregular. Due to this craftmade processing, each product is unique and exclusive.

## NOTE TECNICHE SUI MATERIALI

**OTTONE BRUNITO A MANO** | L'ottone brunito a mano è ottenuto da un processo di ossidazione naturale eseguito manualmente. Il risultato di questa lavorazione è un prodotto che può presentare macchie e variazioni di colore che non sono da considerarsi imperfezioni ma caratteristiche che conferiscono ad ogni pezzo una particolare unicità, rendendolo esclusivo.

## TECHNICAL INFORMATION ON THE MATERIALS

**HAND BURNISHED BRASS** | The hand burnished brass is the consequence of hand-made process of natural oxidation. The result of this processing is a product that may show marks and colour variations. These differences are inevitable and should not be considered imperfections but distinctive features due to this craftmade processing, each product is unique and exclusive.

- ! Non realizzabile su misura.
- ! Cristallo temperato solo per spessore 12mm.

- ! Not available in custom size.
- ! Tempered glass only for thickness 12mm.



### Cm

Spessore 10mm  
 Ø50 x 46,5  
 Ø70 x 39,5  
 Double 107 x 70 x 46,5

### Spessore 12mm

Ø100 x 32  
 Ø130 x 32  
 100 x 100 x 32  
 130 x 130 x 32  
 140 x 70 x 32  
 180 x 76 x 32

### Inches

Thickness 10mm  
 Ø19¾" x 18½"  
 Ø27¾" x 15¾"  
 42½" x 27¾" x 18½"

### Thickness 12mm

Ø39½" x 12¾"  
 Ø51¼" x 12¾"  
 39½" x 39½" x 12¾"  
 51¼" x 51¼" x 12¾"  
 55¼" x 27¾" x 12¾"  
 71" x 30" x 12¾"

For technical drawing / p. 341

Pricelist 2023 / p. 123  
 Homescapes, sense of materials / p. 32

## PIANO/TOP



Cristallo extralight  
 Extralight glass

## STRUTTURA/STRUCTURE



Ottone brunito a mano  
 Hand burnished brass

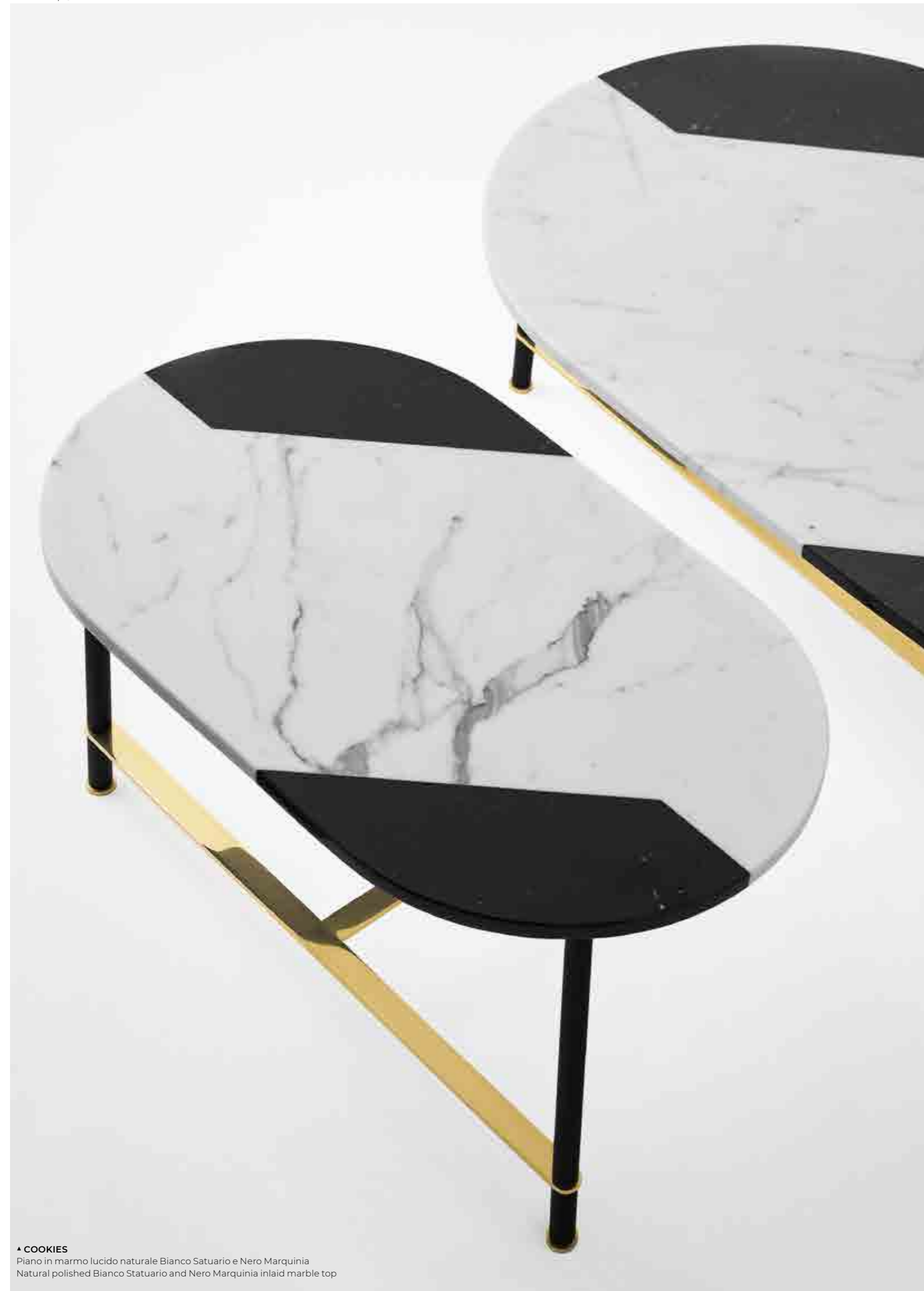

▲ **COOKIES**  
Piano in marmo lucido naturale Bianco Statuario e Nero Marquinia  
Natural polished Bianco Statuario and Nero Marquinia inlaid marble top

# Cookies

Pietro Russo / 2017

Tavolino con piano in marmo lucido naturale Bianco Statuario e Nero Marquinia intarsiato. Disponibile anche con piano in legno intarsiato con motivo "Tweed" oppure in Acero Frisé grigio scuro. Struttura in alluminio spazzolato a mano e anodizzato nero ed ottone lucido. Disponibile versione con piano in marmo lucido naturale Calacatta Vagli Oro e struttura in metallo verniciato bronzo patinato.

Coffee table with natural polished Bianco Statuario and Nero Marquinia marble inlaid top. Also available with inlaid wooden top with "Tweed" pattern or in Maple Frisé dark grey. Black hand brushed anodized aluminium and bright brass structure. Also available version with natural polished Calacatta Vagli Oro marble top and patinated bronze lacquered metal structure.

## NOTE TECNICHE SUI MATERIALI

**MARMO** | Il marmo è un materiale naturale di origine sedimentaria che può presentare particolarità come venature, lievi irregolarità superficiali, colorazioni differenti e cristallizzazioni. Queste peculiarità sono da attribuirsi alla naturalezza del materiale e non sono da considerarsi difetti ma caratteristiche tipiche del marmo. Ogni prodotto risulterà unico, esclusivo e non replicabile. I nostri marmi vengono trattati con un prodotto idrorepellente che permette una maggiore protezione della superficie stessa, aumentando l'impermeabilità. Questo trattamento non esclude la vulnerabilità del marmo alle sostanze acide.

**INTARSIO** | L'intarsio è una tecnica di lavorazione artigianale utilizzata per ottenere un particolare disegno e si realizza accostando elementi di materiali differenti (come legno e alluminio) oppure dello stesso materiale. Questa lavorazione rende il prodotto unico ed esclusivo. Le eventuali variazioni cromatiche, di venatura del legno o di dimensione dei listelli sono da considerarsi caratteristiche del materiale stesso e non possono essere controllate.

## TECHNICAL INFORMATION ON THE MATERIALS

**MARBLE** | The marble is a natural material of sedimentary origin that can present particularities such as veins, slight surface irregularities, different colors and crystallizations. These peculiarities are to be attributed to the naturalness of the material and are not to be considered defects but typical characteristics of marble. Each product will be unique, exclusive and non-replicable. Our marbles are treated with water-repellent products which affords greater protection to the surface of the marble, improving its impermeability. This treatment doesn't exclude the vulnerability of the marble to acid substances.

**INLAY** | Inlay is an artisanal technique used to obtain a particular design and is made by combining elements of different materials (such as wood and aluminium) or of the same material. This process makes the product unique and exclusive. Any changes in colour, wood grain or strip size are to be considered as characteristics of the material itself and cannot be controlled.



**Versione in marmo**  
Marble version

	Cm	Inches
S	70 x 42 x 40	27 <sup>3</sup> / <sub>4</sub> " x 16 <sup>3</sup> / <sub>4</sub> " x 15 <sup>3</sup> / <sub>4</sub> "
M	105 x 62 x 28	41 <sup>1</sup> / <sub>2</sub> " x 24 <sup>1</sup> / <sub>2</sub> " x 11 <sup>1</sup> / <sub>4</sub> "
L	120 x 72 x 23	47 <sup>1</sup> / <sub>2</sub> " x 28 <sup>1</sup> / <sub>2</sub> " x 9 <sup>1</sup> / <sub>4</sub> "

**Versione in legno**  
Wooden version

	Cm	Inches
S	70 x 42 x 40	27 <sup>3</sup> / <sub>4</sub> " x 16 <sup>3</sup> / <sub>4</sub> " x 15 <sup>3</sup> / <sub>4</sub> "
M	105 x 62 x 28	41 <sup>1</sup> / <sub>2</sub> " x 24 <sup>1</sup> / <sub>2</sub> " x 11 <sup>1</sup> / <sub>4</sub> "
L	120 x 72 x 23	47 <sup>1</sup> / <sub>2</sub> " x 28 <sup>1</sup> / <sub>2</sub> " x 9 <sup>1</sup> / <sub>4</sub> "
XL	144 x 86 x 35	56 <sup>3</sup> / <sub>4</sub> " x 34" x 14"

For technical drawing / p. 341

Price list 2023 / p. 125  
Homescapes, sense of materials / pp. 19, 22  
Homescapes, gentle attitude / pp. 86, 88

## VERSIONI DISPONIBILI/AVAILABLE VERSIONS

### PIANO/TOP



Marmo Bianco Statuario/  
Nero Marquinia  
lucido naturale  
Bianco Statuario/  
Nero Marquinia marble  
natural polished

### PIANO/TOP

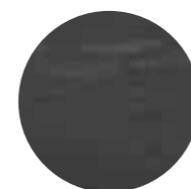

Legno Acero Frisé  
grigio scuro  
Maple Frisé dark grey wood

### STRUTTURA/STRUCTURE



Alluminio spazzolato nero/  
Ottone lucido  
Black brushed aluminium/  
Bright brass

### STRUTTURA/STRUCTURE

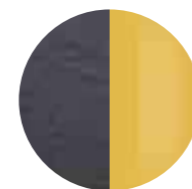

Alluminio spazzolato nero/  
Ottone lucido  
Black brushed aluminium/  
Bright brass

### PIANO/TOP



Legno intarsiato  
con motivo "Tweed"  
Inlaid wood with  
"Tweed" pattern

### PIANO/TOP



Marmo lucido naturale  
Calacatta Vagli Oro  
Natural polished Calacatta  
Vagli Oro marble

### STRUTTURA/STRUCTURE

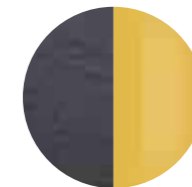

Alluminio spazzolato nero/  
Ottone lucido  
Black brushed aluminium/  
Bright brass

### STRUTTURA/STRUCTURE



Metallo verniciato  
bronzo patinato  
Patinated bronze  
lacquered metal

# Cookies Circle

Pietro Russo / 2019

Tavolino con piano in marmo lucido naturale Verde Alpi, Calacatta Vagli Oro, Bianco Statuario, Nero Marquinia o Travertino Romano spazzolato naturale (non resinato). Struttura in alluminio spazzolato a mano anodizzato nero ed ottone lucido oppure in metallo verniciato bronzo patinato. Disponibile anche versione con piano in legno intarsiato nella finitura Noce "Colore" Frisé oppure Acero Frisé grigio scuro e struttura in alluminio spazzolato a mano anodizzato nero ed ottone lucido.

## NOTE TECNICHE SUI MATERIALI

**MARMO** | Il marmo è un materiale naturale di origine sedimentaria che può presentare particolarità come venature, lievi irregolarità superficiali, colorazioni differenti e cristallizzazioni. Queste peculiarità sono da attribuirsi alla naturalezza del materiale e non sono da considerarsi difetti ma caratteristiche tipiche del marmo. Ogni prodotto risulterà unico, esclusivo e non replicabile. I nostri marmi vengono trattati con un prodotto idrorepellente che permette una maggiore protezione della superficie stessa, aumentando l'impermeabilità. Questo trattamento non esclude la vulnerabilità del marmo alle sostanze acide.

**INTARSIO** | L'intarsio è una tecnica di lavorazione artigianale utilizzata per ottenere un particolare disegno e si realizza accostando elementi di materiali differenti (come legno e alluminio) oppure dello stesso materiale. Questa lavorazione rende il prodotto unico ed esclusivo. Le eventuali variazioni cromatiche e di venatura del legno sono da considerarsi caratteristiche del materiale stesso e non possono essere controllate.

Coffee table with natural polished Verde Alpi, Calacatta Vagli Oro, Bianco Statuario, Nero Marquinia marble to or natural brushed Travertino Romano (not treated with resin). Black hand brushed anodized aluminium and bright brass structure or patinated bronze lacquered metal structure. Also available with inlaid wooden top in the finish "Colore" Frisé Walnut or in Maple Frisé dark grey. Black hand brushed anodized aluminium and bright brass structure.

## TECHNICAL INFORMATION ON THE MATERIALS

**MARBLE** | The marble is a natural material of sedimentary origin that can present particularities such as veins, slight surface irregularities, different colors and crystallizations. These peculiarities are to be attributed to the naturalness of the material and are not to be considered defects but typical characteristics of marble. Each product will be unique, exclusive and non-replicable. Our marbles are treated with water-repellent products which affords greater protection to the surface of the marble, improving its impermeability. This treatment doesn't exclude the vulnerability of the marble to acid substances.

**INLAY** | Inlay is an artisanal technique used to obtain a particular design and is made by combining elements of different materials (such as wood and aluminium) or of the same material. This process makes the product unique and exclusive. Any colour and grain variations of the wood are to be considered as characteristics of the material itself and cannot be controlled.



### • COOKIES CIRCLE

Piano in marmo lucido naturale Calacatta Vagli Oro /  
Struttura in alluminio spazzolato nero e ottone lucido  
Natural polished Calacatta Vagli Oro marble top /  
Black brushed aluminium and bright brass

### • COOKIES CIRCLE

Piano in marmo lucido naturale Verde Alpi / Struttura in alluminio spazzolato nero e ottone lucido  
Natural polished Verde Alpi marble top / Black brushed aluminium and bright brass

For technical drawing / p. 342

Pricelist 2023 / p. 125  
Homescapes, sense of materials / p. 22  
Homescapes, intimate portraits / p. 102  
Homescapes, gentle attitude / pp. 58, 86, 88

**Cm**  
S Ø49 x 35  
L Ø49 x 45

**Inches**  
S Ø19½" x 14"  
L Ø19½" x 17¾"

## PIANO/TOP



Marmo lucido naturale  
Verde Alpi  
Natural polished  
Verde Alpi marble

## STRUTTURA/STRUCTURE



Alluminio spazzolato nero/  
Ottone lucido  
Black brushed aluminium/  
Bright brass

## PIANO/TOP



Marmo lucido naturale  
Verde Alpi  
Natural polished  
Verde Alpi marble

## STRUTTURA/STRUCTURE



Metallo verniciato  
bronzo patinato  
Patinated bronze  
lacquered metal

## PIANO/TOP



Marmo lucido naturale  
Calacatta Vagli Oro  
Natural polished  
Calacatta Vagli Oro marble

## STRUTTURA/STRUCTURE



Alluminio spazzolato nero/  
Ottone lucido  
Black brushed aluminium/  
Bright brass

## PIANO/TOP



Marmo lucido naturale  
Calacatta Vagli Oro  
Natural polished  
Calacatta Vagli Oro marble

## STRUTTURA/STRUCTURE



Metallo verniciato  
bronzo patinato  
Patinated bronze  
lacquered metal

## PIANO/TOP



Marmo lucido naturale  
Bianco Statuario  
Natural polished  
Bianco Statuario marble

## STRUTTURA/STRUCTURE



Alluminio spazzolato nero/  
Ottone lucido  
Black brushed aluminium/  
Bright brass

## PIANO/TOP



Marmo lucido naturale  
Bianco Statuario  
Natural polished  
Bianco Statuario marble

## STRUTTURA/STRUCTURE



Metallo verniciato  
bronzo patinato  
Patinated bronze  
lacquered metal

## PIANO/TOP



Marmo lucido naturale  
Nero Marquinia  
Natural polished  
Nero Marquinia marble

## STRUTTURA/STRUCTURE



Alluminio spazzolato nero/  
Ottone lucido  
Black brushed aluminium/  
Bright brass

## PIANO/TOP



Marmo lucido naturale  
Bianco Statuario  
Natural polished  
Bianco Statuario marble

## STRUTTURA/STRUCTURE



Metallo verniciato  
bronzo patinato  
Patinated bronze  
lacquered metal

## PIANO/TOP



Travertino Romano  
spazzolato naturale  
Natural brushed  
Travertino Romano

## STRUTTURA/STRUCTURE



Alluminio spazzolato nero/  
Ottone lucido  
Black brushed aluminium/  
Bright brass

## PIANO/TOP



Travertino Romano  
spazzolato naturale  
Natural brushed  
Travertino Romano

## STRUTTURA/STRUCTURE



Metallo verniciato  
bronzo patinato  
Patinated bronze  
lacquered metal

## PIANO/TOP



Legno Noce "Colore" Frisé  
"Colore" Frisé Walnut  
wood

## STRUTTURA/STRUCTURE

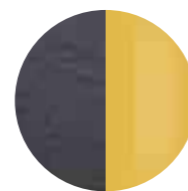

Alluminio spazzolato nero/  
Ottone lucido  
Black brushed aluminium/  
Bright brass

## PIANO/TOP



Legno Acero Frisé  
grigio scuro  
Maple Frisé dark grey  
wood

## STRUTTURA/STRUCTURE



Alluminio spazzolato nero/  
Ottone lucido  
Black brushed aluminium/  
Bright brass

# Dama

Studio G&R / 2015

Tavolino in legno massello tinto nero a poro aperto. Piano in specchio "grigio Italia". Disponibile anche in specchio "Antique 1" oppure marmo lucido naturale Calacatta Vagli Oro o marmo Verde Alpi.

Coffee table in black open pore stained solid wood. Smoked "grigio Italia" mirrored top. Also available in "Antique 1" mirror, natural polished Calacatta Vagli Oro or Verde Alpi marble.

! Il legno massello è molto sensibile alla luce, il posizionamento vicino a sorgenti di luce naturale ne compromette la colorazione e la stabilità. Un'elevata variazione della temperatura e umidità dell'aria può provocare la comparsa di microfratture e leggere variazioni.

! Solid wood is very light-sensitive, placing it near natural light sources may compromise its colour and stability. Considerable differences in air temperature and humidity may cause microfractures and slight variations.

## NOTE TECNICHE SUI MATERIALI

**MARMO** | Il marmo è un materiale naturale di origine sedimentaria che può presentare particolarità come venature, lievi irregolarità superficiali, colorazioni differenti e cristallizzazioni. Queste peculiarità sono da attribuirsi alla naturalezza del materiale e non sono da considerarsi difetti ma caratteristiche tipiche del marmo. Ogni prodotto risulterà unico, esclusivo e non replicabile. I nostri marmi vengono trattati con un prodotto idrorepellente che permette una maggiore protezione della superficie stessa, aumentando l'impermeabilità. Questo trattamento non esclude la vulnerabilità del marmo alle sostanze acide.

## TECHNICAL INFORMATION ON THE MATERIALS

**MARBLE** | The marble is a natural material of sedimentary origin that can present particularities such as veins, slight surface irregularities, different colors and crystallizations. These peculiarities are to be attributed to the naturalness of the material and are not to be considered defects but typical characteristics of marble. Each product will be unique, exclusive and non-replicable. Our marbles are treated with water-repellent products which affords greater protection to the surface of the marble, improving its impermeability. This treatment doesn't exclude the vulnerability of the marble to acid substances.



### Piano in specchio

Mirrored top

	Cm	Inches
S	Ø41 x 45	Ø16¼" x 17¾"
L	Ø38 x 55	Ø15" x 21¾"

### Piano in marmo

Marble top

	Cm	Inches
S	Ø41 x 46	Ø41 x 46
L	Ø38 x 56	Ø38 x 56

[For technical drawing / p. 342](#)

[Pricelist 2023 / p. 126](#)  
[Homescapes, sense of materials / p. 111](#)  
[Homescapes, gentle attitude / pp. 37, 39, 41, 43, 72, 74](#)

## STRUTTURA / STRUCTURE

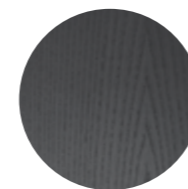

**Legno tinto nero a poro aperto**  
Black open pore stained wood

## PIANO / TOP



**Specchio "grigio Italia"**  
"Grigio Italia" smoked mirror



**Specchio Antique 1**  
Antique 1 mirror



**Marmo lucido naturale Calacatta Vagli Oro**  
Natural polished Calacatta Vagli Oro marble



**Marmo lucido naturale Verde Alpi**  
Natural polished Verde Alpi marble

▲ DAMA  
Piano in marmo Calacatta Vagli Oro / Struttura in legno tinto nero a poro aperto  
Calacatta Vagli Oro marble top / Black open pore stained solid wood structure





# Drummers

Masismo Castagna / 2023

Tavolino in poliuretano rigido rivestito in calce spatolata nel color "burro".

Coffee table in rigid polyurethane covered with spatulated lime in the "burro" color.



**Cm**  
Ø31 x 45  
60,3 x 60,7 x 27  
88,3 x 88,2 x 20

**Inches**  
Ø12¼" x 17¾"  
23¾" x 24" x 10¾"  
35" x 34¾" x 8"

[For technical drawing / p. 342](#)

[Pricelist 2023 / p. 127](#)

## STRUTTURA / STRUCTURE



**Calce spatolata color "burro"**  
Spatulated lime in the "burro" color.



▲ FANTE  
Piano in specchio Antique 1 / Struttura in legno tinto nero a poro aperto  
"Antique 1" mirrored top / Black open pore stained solid wood structure

# Fante

Studio G&R / 2015

Tavolino in legno massello tinto nero a poro aperto. Piano in specchio "grigio Italia". Disponibile anche in specchio "Antique 1" oppure marmo lucido naturale Calacatta Vagli Oro o marmo Verde Alpi.

! Sconsigliato posizionamento su tappeto.

Il legno massello è molto sensibile alla luce, il posizionamento vicino a sorgenti di luce naturale ne compromette la colorazione e la stabilità. Un'elevata variazione della temperatura e umidità dell'aria può provocare la comparsa di microfessure e leggere variazioni.

## NOTE TECNICHE SUI MATERIALI

**MARMO** | Il marmo è un materiale naturale di origine sedimentaria che può presentare particolarità come venature, lievi irregolarità superficiali, colorazioni differenti e cristallizzazioni. Queste peculiarità sono da attribuirsi alla naturalezza del materiale e non sono da considerarsi difetti ma caratteristiche tipiche del marmo. Ogni prodotto risulterà unico, esclusivo e non replicabile. I nostri marmi vengono trattati con un prodotto idrorepellente che permette una maggiore protezione della superficie stessa, aumentando l'impermeabilità. Questo trattamento non esclude la vulnerabilità del marmo alle sostanze acide.

Coffee table in black open pore stained solid wood. Smoked "grigio Italia" mirrored top. Also available in "Antique 1" mirror, natural polished Calacatta Vagli Oro or Verde Alpi marble.

! Not recommended for positioning on carpet.

Solid wood is very light-sensitive, placing it near natural light sources may compromise its colour and stability. Considerable differences in air temperature and humidity may cause microfractures and slight variations.

## TECHNICAL INFORMATION ON THE MATERIALS

**MARBLE** | The marble is a natural material of sedimentary origin that can present particularities such as veins, slight surface irregularities, different colors and crystallizations. These peculiarities are to be attributed to the naturalness of the material and are not to be considered defects but typical characteristics of marble. Each product will be unique, exclusive and non-replicable. Our marbles are treated with water-repellent products which affords greater protection to the surface of the marble, improving its impermeability. This treatment doesn't exclude the vulnerability of the marble to acid substances.



**Piano in specchio**  
Mirrored top

	Cm	Inches
S	Ø46 x 50	Ø18¼" x 19¾"
L	Ø38 x 63	Ø15" x 25"

**Piano in marmo**  
Marble top

	Cm	Inches
S	Ø46 x 51	Ø18¼" x 20¼"
L	Ø38 x 64	Ø15" x 25¼"

[For technical drawing / p.343](#)

[Pricelist 2023 / p.128](#)  
[Homescapes, sense of materials / p.73](#)  
[Homescapes, embracing beauty / p.55](#)  
[Homescapes, gentle attitude / pp.37,39,41,43,72,74](#)

## STRUTTURA/STRUCTURE

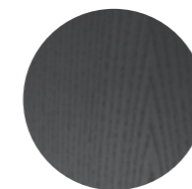

**Legno tinto nero a poro aperto**  
Black open pore stained wood

## PIANO/TOP



**Specchio "grigio Italia"**  
"Grigio Italia" smoked mirror



**Specchio Antique 1**  
Antique 1 mirror



**Marmo lucido naturale Calacatta Vagli Oro**  
Natural polished Calacatta Vagli Oro marble



**Marmo lucido naturale Verde Alpi**  
Natural polished Verde Alpi marble

# Faraday

Mårten Claesson, Ola Rune, Eero Koivisto / 2007

Tavolino con piano superiore in cristallo trasparente temperato 8mm e piano inferiore in cristallo trasparente temperato 8mm o retroverniciato nei colori del campionario nella versione brillante o satinata. Struttura in acciaio inox lucido. Su richiesta struttura in ottone satinato.

Coffee table with 8mm transparent tempered glass top and 8mm transparent or painted tempered glass bottom as per samples in the bright or satin version. Bright stainless steel structure. On request, satin brass structure.



	Cm	Inches
F01	125 x 125 x 27	49 1/4" x 49 1/4" x 10 3/4"
F02	50 x 125 x 27	19 3/4" x 49 1/4" x 10 3/4"
F02	77 x 125 x 27	30 1/2" x 49 1/4" x 10 3/4"
F03	80 x 80 x 27	31 1/2" x 31 1/2" x 10 3/4"
F03	100 x 100 x 27	39 1/2" x 39 1/2" x 10 3/4"
F03	125 x 125 x 27	49 1/4" x 49 1/4" x 10 3/4"

For technical drawing / p.343

Pricelist 2023 / p. 129

▲ FARADAY  
Piano superiore in cristallo trasparente / Piano inferiore in cristallo retroverniciato nero satinato / Struttura in acciaio inox lucido  
Transparent glass top / Black satin glass bottom / Bright stainless steel structure

## STRUTTURA/STRUCTURE



Acciaio inox lucido  
Bright stainless steel



Ottone satinato  
Satin brass

## PIANO SUPERIORE/TOP



Cristallo trasparente  
Transparent glass

## PIANO INFERIORE/BOTTOM

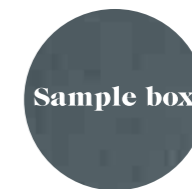

Cristallo brillante/satinato  
nei colori del campionario  
Glass bright/satin version  
as per samples

# George 1

Pierangelo Gallotti / 1975

Mobile carrello in cristallo trasparente, extralight o "grigio Italia" temperato 8mm. Disponibile con o senza mensola. Parti metalliche in acciaio inox lucido. A richiesta acciaio inox satinato, ottone lucido, satinato o laccato bianco o nero goffrato. Disponibile versione senza ruote (altezza finita: 34cm).

Coffee table on castors in 8mm transparent, extralight or smoked "grigio Italia" tempered glass. Available with or without shelf. Bright stainless steel metal parts. Satin stainless steel, bright, satin or embossed white or black lacquered brass metal parts on request. Available version without castors (total height: 34cm).

! Nella versione acciaio inox lucido le ruote sono nere con copriruota cromato.  
! Nelle altre versioni disponibili le ruote sono completamente nere.

! In the bright stainless steel version the castors are black with chrome castors cover.  
! In the other available versions the castors are completely black.

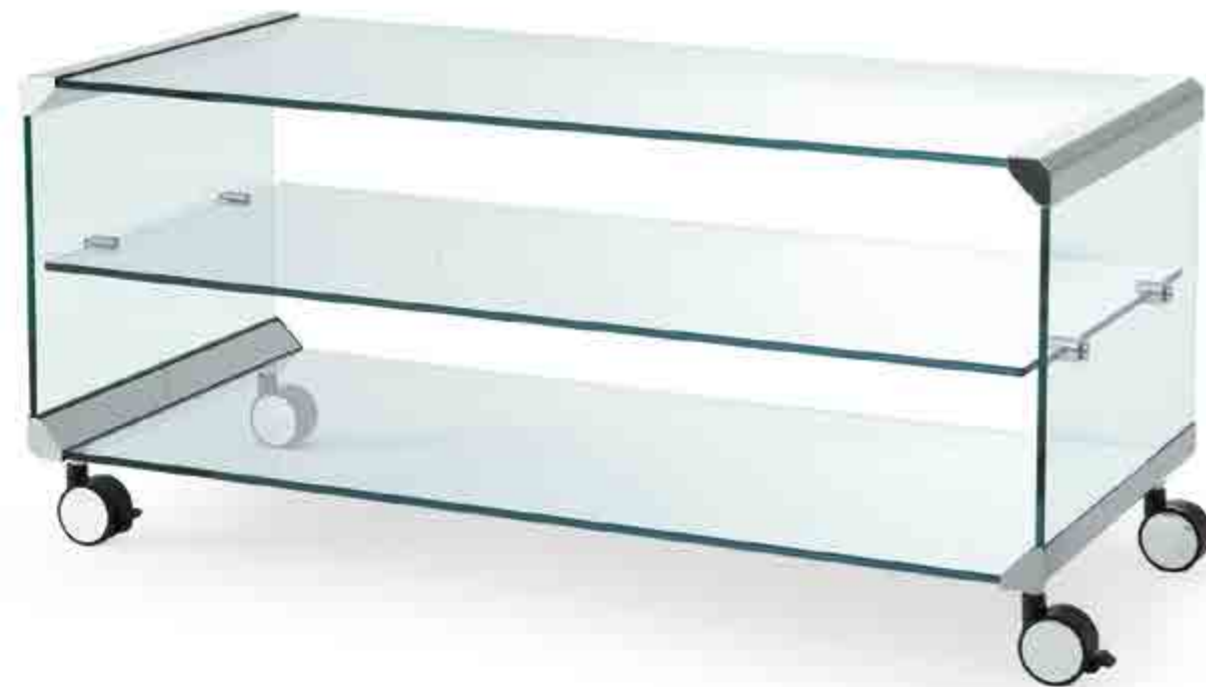

## Cm

45 x 40 x 48\*  
68 x 40 x 48\*  
80 x 40 x 48\*  
45 x 40 x 48  
68 x 40 x 48  
80 x 40 x 48  
100 x 45 x 45  
120 x 45 x 45  
130 x 45 x 45  
130 x 54 x 45

## Inches

17 3/4" x 15 3/4" x 19\*\*  
27" x 15 3/4" x 19\*\*  
31 1/2" x 15 3/4" x 19\*\*  
17 3/4" x 15 3/4" x 19"  
27 1/2" x 15 3/4" x 19"  
31 1/2" x 15 3/4" x 19"  
39 1/2" x 17 3/4" x 17 3/4"  
47 1/4" x 17 3/4" x 17 3/4"  
51 1/4" x 17 3/4" x 17 3/4"  
51 1/4" x 21 1/2" x 17 3/4"

\* senza mensola

\* without shelf

For technical drawing / p.343

Pricelist 2023 / p.131

## PIANO/TOP



Cristallo trasparente  
Transparent glass



Cristallo "grigio Italia"  
Smoked "grigio Italia" glass



Cristallo extralight  
Extralight glass

## PARTI METALLICHE/METAL PARTS



Acciaio inox lucido  
Bright stainless steel

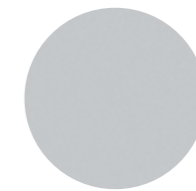

Acciaio inox satinato  
Satin stainless steel

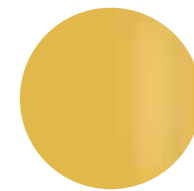

Ottone lucido  
Bright brass



Ottone satinato  
Satin brass



Laccato bianco goffrato  
Embossed white lacquered

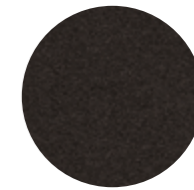

Laccato nero goffrato  
Embossed black lacquered

# George 2

Pierangelo Gallotti / 1975

Tavolino con ruote in cristallo trasparente, extralight o "grigio Italia" temperato 8mm. Parti metalliche in acciaio inox lucido. A richiesta acciaio inox satinato, ottone lucido, satinato o laccato bianco o nero goffrato. Disponibile versione senza ruote (altezza finita: 34cm).

! Nella versione acciaio inox lucido le ruote sono nere con copriruota cromato.  
! Nelle altre versioni disponibili le ruote sono completamente nere.

Coffee table on castors in 8mm transparent, extralight or smoked "grigio Italia" tempered glass. Bright stainless steel metal parts. Satin stainless steel, bright, satin or embossed white or black lacquered brass metal parts on request. Available version without castors (total height: 34cm).

! In the bright stainless steel version the castors are black with chrome castors cover.  
! In the other available versions the castors are completely black.

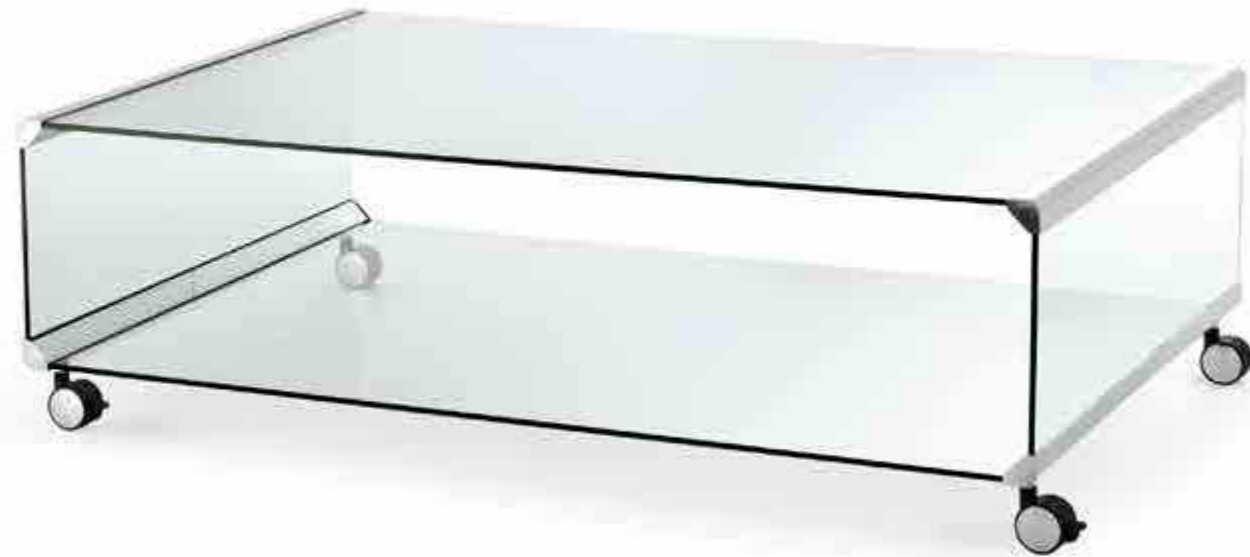

#### Cm

80 x 80 x 42  
100 x 54 x 42  
130 x 54 x 42  
140 x 80 x 42

#### Inches

31½" x 31½" x 16¾"  
39½" x 21½" x 16¾"  
51¼" x 21½" x 16¾"  
55¼" x 31½" x 16¾"

[For technical drawing / p. 344](#)

[Pricelist 2023 / p. 133](#)

#### PIANO/TOP



**Cristallo trasparente**  
Transparent glass



**Cristallo "grigio Italia"**  
Smoked "grigio Italia" glass



**Cristallo extralight**  
Extralight glass

#### PARTI METALLICHE/METAL PARTS



**Acciaio inox lucido**  
Bright stainless steel

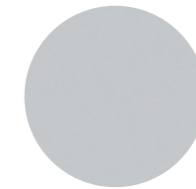

**Acciaio inox satinato**  
Satin stainless steel

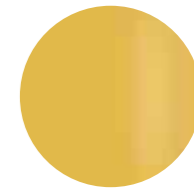

**Ottone lucido**  
Bright brass



**Ottone satinato**  
Satin brass



**Laccato bianco goffrato**  
Embossed white lacquered



**Laccato nero goffrato**  
Embossed black lacquered



# Golden Moon

Massimo Castagna / 2015

Tavolino con piano in cristallo extralight temperato 12mm oppure retroverniciato nei colori del campionario, nella versione brillante o satinata. Disponibile anche con piano in cristallo "grigio Italia" 12mm. Piatto in ottone lucido. Struttura in ottone brunito a mano. L'ottone risulta naturalmente macchiato e disomogeneo. Questa lavorazione artigianale conferisce ad ogni pezzo una particolare unicità, rendendolo esclusivo. Su richiesta versione senza piatto in ottone lucido.

! La ciotola è in ottone lucido naturale non protetto, per mantenere nel tempo la lucentezza del piatto in ottone, si consiglia di utilizzare prodotti specifici.

## NOTE TECNICHE SUI MATERIALI

**OTTONE BRUNITO A MANO** | L'ottone brunito a mano è ottenuto da un processo di ossidazione naturale eseguito manualmente. Il risultato di questa lavorazione è un prodotto che può presentare macchie e variazioni di colore che non sono da considerarsi imperfezioni ma caratteristiche che conferiscono ad ogni pezzo una particolare unicità, rendendolo esclusivo.

Coffee table with 12mm extralight tempered glass top or painted glass as per samples in the bright or satin version. Also available with 12mm smoked "grigio Italia" glass top. Bright brass plate. Structure in hand burnished brass. The hand burnished brass finish looks naturally spotted and irregular. Due to this craftmade processing, each product is unique and exclusive. On request, version without bright brass plate.

! The plate is in bright natural brass not protected, in order to maintain the brightness of the brass plate, we suggest to use specific product.

## TECHNICAL INFORMATION ON THE MATERIALS

**HAND BURNISHED BRASS** | The hand burnished brass is the consequence of hand-made process of natural oxidation. The result of this processing is a product that may show marks and colour variations. These differences are inevitable and should not be considered imperfections but distinctive features due to this craftmade processing, each product is unique and exclusive.



## Cm

100 x 60 x 35  
100 x 100 x 35  
130 x 70 x 35

## Inches

39½" x 23¾" x 14"  
39½" x 39½" x 14"  
51¼" x 27¾" x 14"

[For technical drawing / p. 344](#)

[Pricelist 2023 / p. 134](#)

## PIANO/TOP



Cristallo extralight  
Extralight glass



Cristallo brillante/satinato  
nei colori del campionario  
Glass bright/satin version  
as per samples



Cristallo "grigio Italia"  
"Grigio Italia" glass

## PIATTO/PLATE



Ottone lucido  
Bright brass

## STRUTTURA/STRUCTURE



Ottone brunito a mano  
Hand burnished brass



▲ GONG  
Piano in legno bisellato "Autumn Weave"  
"Autumn Weave" wooden bevelled top

# Gong

Studio G&R / 2017

Tavolino in legno bisellato e decorato con lavorazione manuale ed esclusiva, disponibile nella versione "Autumn Weave" su base foglia oro oppure "Carbon Black" su base foglia rame.  
Zoccolo in legno rivestito foglia oro.  
Disponibile anche versione "Winter Weave" su base foglia argento con zoccolo in legno rivestito in foglia argento.

## NOTE TECNICHE SUI MATERIALI

**FINITURE ARTIGIANALI** | Le finiture manuali ed esclusive risultano dal processo di ossidazione di foglia d'argento, oro e rame, che possono presentare macchie e striature, oltre a differenze cromatiche. Tali disomogeneità sono caratteristiche che non devono essere considerate difetti ma elementi distintivi, tipici dell'ossidazione manuale, che esaltano la bellezza e la peculiarità del pezzo unico.

Wooden coffee table bevelled and decorated by hand with an exclusive treatment, available in "Autumn Weave" version on gold leaf base or "Carbon Black" version on copper leaf base.  
Wooden plinth covered by gold leaf.  
Also available version "Winter Weave" on silver leaf base with wooden plinth covered by silver leaf.

## TECHNICAL INFORMATION ON THE MATERIALS

**ARTISANAL FINISHES** | Artisanal and exclusive finishes that are obtained from the oxidation of silver, gold and copper leaves may show marks and spots, as well as variations in colour. These differences are inevitable and should not be considered imperfections but evidence of the hand-crafted process. They enhance the beauty and distinctiveness of a unique piece.



	Cm	Inches
S	Ø45 x 40	17¾" x 15¾"
M	Ø70 x 31	27¾" x 12¼"
L	Ø90 x 23	35½" x 9¼"

For technical drawing / p. 344

Pricelist 2023 / p. 135  
Homescapes, sense of materials / p. 8  
Homescapes, gentle attitude / pp. 21, 24, 25

## PIANO/TOP

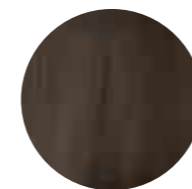

"Autumn Weave"



"Carbon black"



Foglia oro  
Gold leaf

## ZOCOLO/PLINTH

## PIANO/TOP



"Winter Weave"



Foglia argento  
Silver leaf

## ZOCOLO/PLINTH

# Haumea

Massimo Castagna / 2015

Tavolino con piano in cristallo temperato extralight 10mm.  
Su richiesta piano in cristallo temperato "grigio Italia" 10mm.  
Base in frassino tinto nero a poro aperto, "Pure" bianco a poro aperto o laccato ruggine. Cilindro centrale in metallo ottonato lucido, brunito a mano, ramato, cromato nero, laccato bianco o nichelato lucido.  
Ciotola disponibile in ottone lucido, ottone cromato nero, ottone nichelato lucido o ottone laccato bianco. Disponibile nelle combinazioni sotto elencate.  
Per versione XS e S: sconsigliato posizionamento su tappeto.

## NOTE TECNICHE SUI MATERIALI

**OTTONE BRUNITO A MANO** | L'ottone brunito a mano è ottenuto da un processo di ossidazione naturale eseguito manualmente. Il risultato di questa lavorazione è un prodotto che può presentare macchie e variazioni di colore che non sono da considerarsi imperfezioni ma caratteristiche che conferiscono ad ogni pezzo una particolare unicità, rendendolo esclusivo.

! Per versione XS e S: sconsigliato posizionamento su tappeto.

Coffee table with 10mm extralight tempered glass top. 10mm tempered smoked "grigio Italia" glass, on request.  
Black or "Pure" white open pore stained ash or rust lacquered wooden base. Central cylinder in bright brass-plated, hand burnished, copper-plated, black chromed, white lacquered or bright nickel-plated metal.  
Bowl available in bright brass, black chromed brass, bright nickel-plated brass or white lacquered brass. Available in the combinations as per our list below.  
For XS and S versions: not recommended for positioning on carpet.

## TECHNICAL INFORMATION ON THE MATERIALS

**HAND BURNISHED BRASS** | The hand burnished brass is the consequence of hand-made process of natural oxidation. The result of this processing is a product that may show marks and colour variations. These differences are inevitable and should not be considered imperfections but evidence of the hand-crafted process. They enhance the beauty and distinctiveness of a unique piece.

! For XS and S versions: not recommended for positioning on carpet.





	Cm	Inches
<b>XS</b>	Ø50 x 48	Ø19¾" x 19"
<b>S</b>	Ø50 x 56	Ø19¾" x 22¼"
<b>M</b>	Ø80 x 40	Ø31½" x 15¾"
<b>L</b>	Ø120 x 33	Ø47¼" x 13"

For technical drawing / p. 345

Pricelist 2023 / p. 136  
Homescapes, sense of materials / p. 9  
Homescapes, embracing beauty / p. 25  
Homescapes, gentle attitude / pp. 73, 76, 78, 103

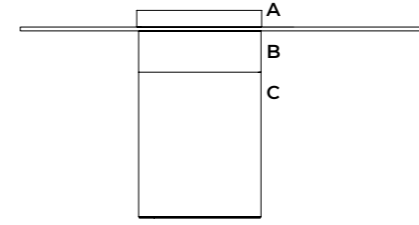
## COMBINAZIONI COMBINATIONS

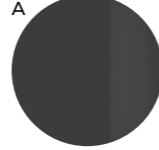

<b>COMB. 1</b>	A  Ottone lucido Bright brass	B  Ottone brunito Burnished brass	C  Frassino tinto nero a poro aperto Black open pore stained ash	<b>PIANO/TOP</b>  Cristallo extralight Extralight glass
<b>COMB. 2</b>	A  Ottone lucido Bright brass	B  Ottone lucido Bright brass	C  Ruggine Rust	<b>PIANO/TOP</b>  Cristallo extralight Extralight glass
<b>COMB. 3</b>	A  Ottone cromato nero Black chromed brass	B  Ottone cromato nero Black chromed brass	C  Frassino tinto nero a poro aperto Black open pore stained ash	<b>PIANO/TOP</b>  Cristallo extralight Extralight glass
<b>COMB. 4</b>	A  Ottone cromato nero Black chromed brass	B  Ottone ramato Coppered brass	C  Ruggine Rust	<b>PIANO/TOP</b>  Cristallo extralight Extralight glass
<b>COMB. 5</b>	A  Ottone cromato nero Black chromed brass	B  Ottone brunito Burnished brass	C  Ruggine Rust	<b>PIANO/TOP</b>  Cristallo extralight Extralight glass
<b>COMB. 6</b>	A  Ottone cromato nero Black chromed brass	B  Ottone brunito Burnished brass	C  Frassino tinto nero a poro aperto Black open pore stained ash	<b>PIANO/TOP</b>  Cristallo extralight Extralight glass
<b>COMB. 7</b>	A  Ottone nichelato lucido Bright nickel-plated brass	B  Metallo nichelato lucido Bright nickel-plated metal	C  Frassino tinto "Pure" bianco a poro aperto "Pure" white open pore stained ash	<b>PIANO/TOP</b>  Cristallo extralight Extralight glass
<b>COMB. 8</b>	A  Ottone laccato bianco opaco Mat white lacquered brass	B  Metallo laccato bianco lucido Glossy white lacquered metal	C  Frassino tinto "Pure" bianco a poro aperto "Pure" white open pore stained ash	<b>PIANO/TOP</b>  Cristallo extralight Extralight glass





• HAUMEA  
Combinazione 1: Piano in cristallo trasparente temperato / Base in frassino tinto nero a poro aperto / Ottone brunito / Vassoio in ottone lucido  
Combination 1: Transparent tempered glass top / Black open pore stained ash base / Burnished brass / Bright brass tray



• HAUMEA  
Combinazione 7: Piano in cristallo trasparente temperato / Base in frassino tinto bianco poro aperto / Metallo nichelato lucido / Vassoio in ottone nichelato lucido  
Combination 7: Transparent tempered glass top / White open pore stained ash base / Bright nickel-plated metal / Bright nickel-plated brass



• HAUMEA  
Combinazione 8: Piano in cristallo trasparente temperato / Base in frassino tinto bianco poro aperto / Metallo laccato bianco lucido / Vassoio in ottone laccato bianco opaco  
Combination 8: Transparent tempered glass top / White open pore stained ash base / Glossy white lacquered metal / Mat white lacquered brass



▲ **HIDE&SEEK MINI**  
Struttura in legno laccato opaco "Sabbia del Nilo"  
"Sabbia del Nilo" opaque lacquered wood structure

# Hide&Seek Mini

Pietro Russo/2024

Tavolino con struttura, cilindro girevole e ripiano in legno laccato lucido o opaco. Colori disponibili: "Bianco Camargue", "Sabbia del Nilo", "Rosa Jaipur", "Rosso Persia", "Bordeaux Etruria", "Verde Provenza", "Blu Pacifico", "Grigio Londra" e "Nero Giza".

Coffee table with structure, rotating half-cylinder and shelf in glossy or opaque lacquered wood. Available colours: "Bianco Camargue", "Sabbia del Nilo", "Rosa Jaipur", "Rosso Persia", "Bordeaux Etruria", "Verde Provenza", "Blu Pacifico", "Grigio Londra" and "Nero Giza".



**Cm**  
Ø47 x 44,5h

**Inches**  
18¾" x 17¾"

[For technical drawing / p. 345](#)

[Pricelist 2023 / p. 225](#)  
[Homescapes, gentle attitude / p. 69](#)

## STRUTTURA/STRUCTURE



Legno laccato lucido  
"Bianco Camargue"  
"Bianco Camargue" glossy  
lacquered wood



Legno laccato opaco  
"Bianco Camargue"  
"Bianco Camargue" opaque  
lacquered wood



Legno laccato lucido  
"Sabbia del Nilo"  
"Sabbia del Nilo" glossy  
lacquered wood



Legno laccato opaco  
"Sabbia del Nilo"  
"Sabbia del Nilo" opaque  
lacquered wood

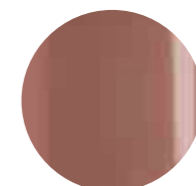

Legno laccato lucido  
"Rosa Jaipur"  
"Rosa Jaipur" glossy  
lacquered wood

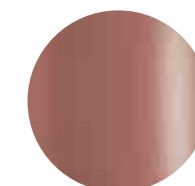

Legno laccato opaco  
"Rosa Jaipur"  
"Rosa Jaipur" opaque  
lacquered wood



Legno laccato lucido  
"Rosso Persia"  
"Rosso Persia" glossy  
lacquered wood

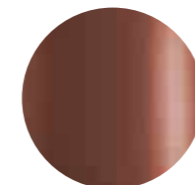

Legno laccato opaco  
"Rosso Persia"  
"Rosso Persia" opaque  
lacquered wood

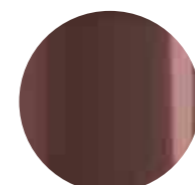

Legno laccato lucido  
"Bordeaux Etruria"  
"Bordeaux Etruria" glossy  
lacquered wood

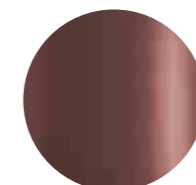

Legno laccato opaco  
"Bordeaux Etruria"  
"Bordeaux Etruria" opaque  
lacquered wood



Legno laccato lucido  
"Verde Provenza"  
"Verde Provenza" glossy  
lacquered wood

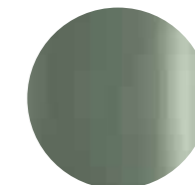

Legno laccato opaco  
"Verde Provenza"  
"Verde Provenza" opaque  
lacquered wood

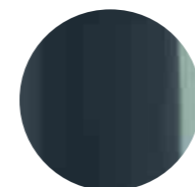

Legno laccato lucido  
"Blu Pacifico"  
"Blu Pacifico" glossy  
lacquered wood

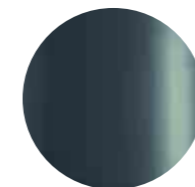

Legno laccato opaco  
"Blu Pacifico"  
"Blu Pacifico" opaque  
lacquered wood



Legno laccato lucido  
"grigio Londra"  
"Grigio Londra" glossy  
lacquered wood

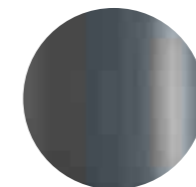

Legno laccato opaco  
"grigio Londra"  
"Grigio Londra" opaque  
lacquered wood



Legno laccato lucido  
"Nero Giza"  
"Nero Giza" glossy  
lacquered wood



Legno laccato opaco  
"Nero Giza"  
"Nero Giza" opaque  
lacquered wood

# Monete

Massimo Castagna / 2021

Tavolino in metallo brunito a mano. Il metallo risulta naturalmente macchiato e disomogeneo. Questa lavorazione artigianale conferisce ad ogni pezzo una particolare unicità, rendendolo esclusivo. Disponibile anche versione in metallo laccato opaco nei colori "oxide red" (RAL 3009) o "black green" (RAL 6012).

Coffee table in hand burnished metal. The metal looks naturally spotted and irregular. Due to this craftmade processing, each product is unique and exclusive. Also available mat lacquered metal version in the colours "oxide red" (RAL 3009) or "black green" (RAL 6012).

## NOTE TECNICHE SUI MATERIALI

**METALLO BRUNITO A MANO** | La finitura artigianale metallo brunito a mano è ottenuta manualmente da un processo di acidatura in grado di conferire particolari effetti cromatici dalle diverse tonalità che variano dal marrone scuro al grigio. Una volta fermato il processo di acidatura, il tavolino viene coperto con una vernice protettiva.

## TECHNICAL INFORMATION ON THE MATERIALS

**HAND BURNISHED METAL** | The handcrafted finish hand burnished metal is the consequence of hand-made process of acid etching which gives particular chromatic effects of different tonalities that goes from dark brown to grey. Once the etching process has stopped the coffee table is covered by protective varnish.



• **MONETE**  
Versione A: Metallo brunito a mano  
Version A: hand burnished brass



	Cm	Inches
A	47 x 48 x 52	18¾" x 19" x 20½"
B	52 x 55 x 47	20½" x 21¾" x 18¾"

For technical drawing / p. 345

Pricelist 2023 / p. 138  
Homescapes, intimate portraits / pp. 64, 70  
Homescapes, gentle attitude / pp. 21, 24

## STRUTTURA/STRUCTURE



Metallo brunito a mano  
Hand burnished metal



Metallo laccato opaco  
"oxide red" (RAL 3009)  
Mat lacquered metal  
"oxide red" (RAL 3009)



Metallo laccato opaco  
"black green" (RAL 6012)  
Mat lacquered metal  
"black green" (RAL 6012)

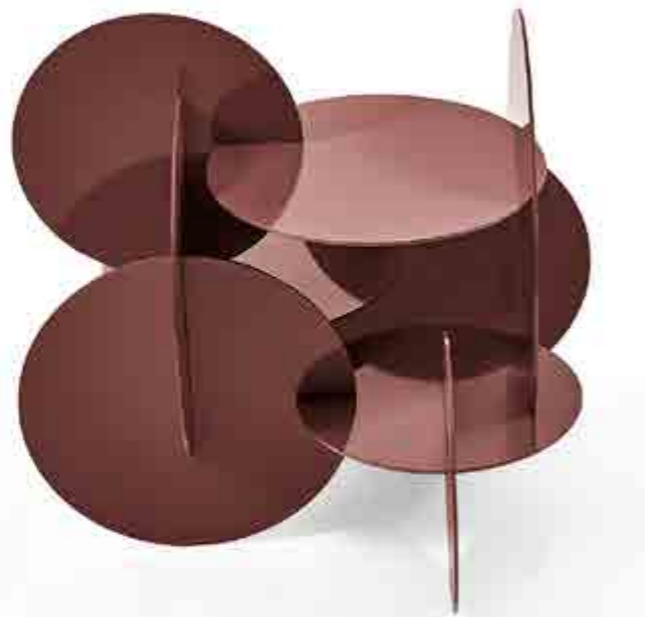

• **MONETE**  
Metallo laccato lucido "oxide red" (RAL 3009)  
Glossy lacquered metal "oxide red" (RAL 3009)



• **MONETE**  
Metallo laccato lucido "black green" (RAL 6012)  
Glossy lacquered metal "black green" (RAL 6012)

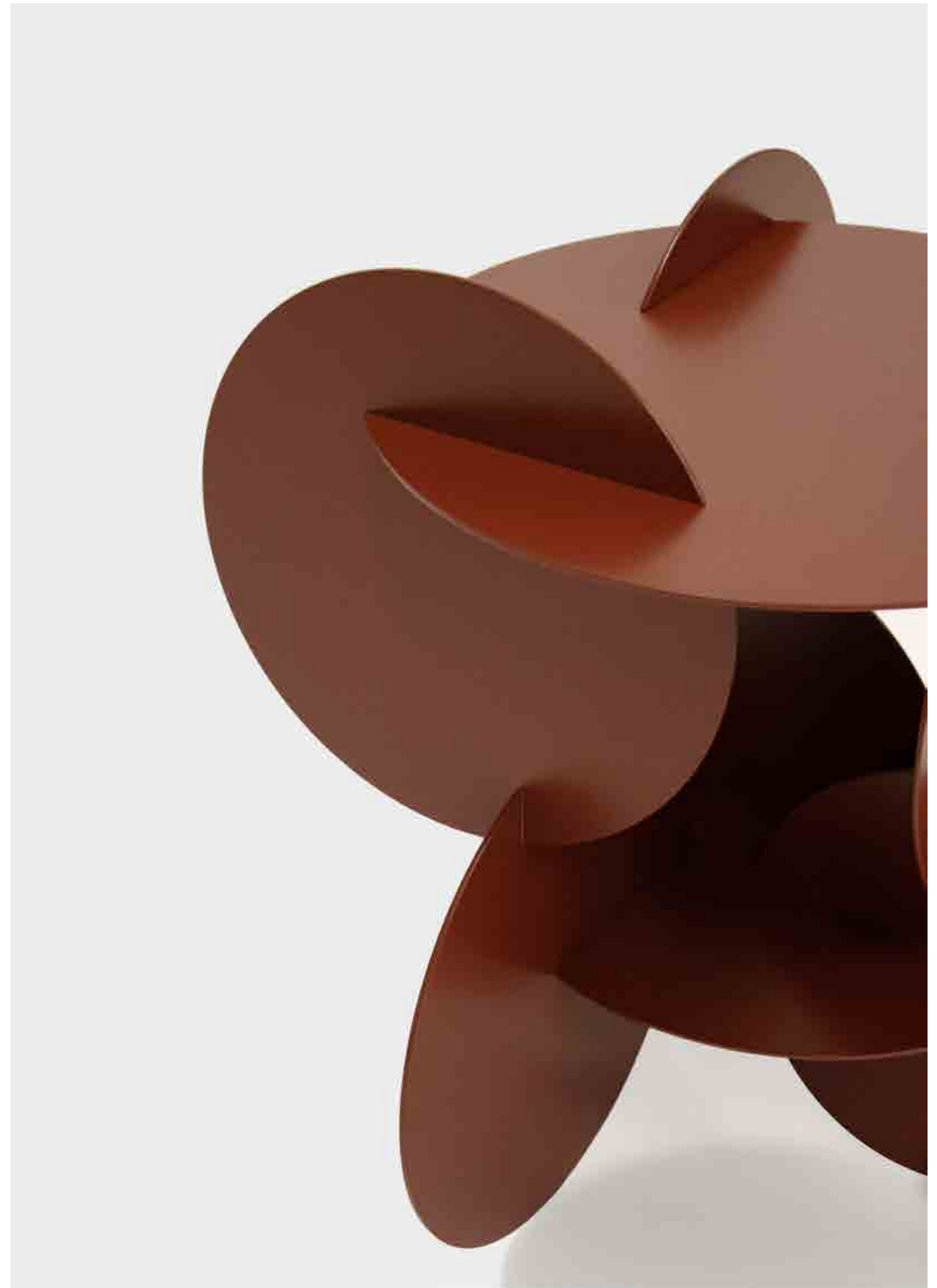



▲ **NORI**  
Piano in legno "Rosso Marte"  
"Rosso Marte" wooden top

# Nori

Studio G&R / 2018

Tavolino in legno massello tinto nero, rivestito con fascia zigrinata a mano. Piano in pelle Fard nei colori del campionario. Disponibile versione con piano in marmo nelle finiture lucido naturale Calacatta Vagli Oro, Verde Alpi, spazzolato Fior di Pesco oppure versione con piano in legno "Rosso Marte" oppure verniciato nella finitura esclusiva bronzo antico e piombo oppure verniciato con finitura esclusiva spazzolata "Cashmere" gold grey o anthracite. Zoccolo in ottone brunito a mano oppure ottone brunito scuro, da definire al momento dell'ordine.

## NOTE TECNICHE SUI MATERIALI

**PELLE FARD** | Tutto il vissuto del manto resta completamente visibile e si manifesta in venature, graffi, possibili variazioni cromatiche, naturali arricciature, che conferiscono a questa pelle una preziosità unica.

**MARMO** | Il marmo è un materiale naturale di origine sedimentaria che può presentare particolarità come venature, lievi irregolarità superficiali, colorazioni differenti e cristallizzazioni. Queste peculiarità sono da attribuirsi alla naturalezza del materiale e non sono da considerarsi difetti ma caratteristiche tipiche del marmo. Ogni prodotto risulterà unico, esclusivo e non replicabile. I nostri marmi vengono trattati con un prodotto idrorepellente che permette una maggiore protezione della superficie stessa, aumentando l'impermeabilità. Questo trattamento non esclude la vulnerabilità del marmo alle sostanze acide.

**FINITURE ESCLUSIVE** | Le finiture esclusive risultato della lavorazione manuale possono presentare striature e differenze cromatiche. Queste caratteristiche non devono essere considerate difetti ma elementi distintivi del processo artigianale che esaltano la bellezza e la peculiarità del pezzo unico.

**OTTONE BRUNITO A MANO** | L'ottone brunito a mano è ottenuto da un processo di ossidazione naturale eseguito manualmente. Il risultato di questa lavorazione è un prodotto che può presentare macchie e variazioni di colore che non sono da considerarsi imperfezioni ma caratteristiche che conferiscono ad ogni pezzo una particolare unicità, rendendolo esclusivo.

Coffee table in black stained solid wood, covered by hand-knurled border part. Fard leather top available as per sample. Also available version with marble top in natural polished Calacatta Vagli Oro, Verde Alpi or brushed Fior di Pesco or with wooden top "Rosso Marte" or painted with the exclusive antique bronze and lead finish or with the exclusive "Cashmere" brushed finish in the colours gold grey or anthracite. Hand burnished or dark burnished brass plinth, to be specified when ordering.

## TECHNICAL INFORMATION ON THE MATERIALS

**FARD LEATHER** | The layer's past is fully visible and is expressed in the grain, possible colour variations, and natural crimping, which give this leather a unique precious feel.

**MARBLE** | The marble is a natural material of sedimentary origin that can present particularities such as veins, slight surface irregularities, different colors and crystallizations. These peculiarities are to be attributed to the naturalness of the material and are not to be considered defects but typical characteristics of marble. Each product will be unique, exclusive and non-replicable. Our marbles are treated with water-repellent products which affords greater protection to the surface of the marble, improving its impermeability. This treatment doesn't exclude the vulnerability of the marble to acid substances.

**EXCLUSIVE FINISHES** | Exclusive finishes, resulting from the craftsmanship, may show streaks and chromatic differences. These characteristics should not be considered imperfections but distinctive evidence of the hand-made process that enhance the beauty and peculiarity of the unique piece.

**HAND BURNISHED BRASS** | The hand burnished brass is the consequence of hand-made process of natural oxidation. The result of this processing is a product that may show marks and colour variations. These differences are inevitable and should not be considered imperfections but distinctive features due to this craftmade processing, each product is unique and exclusive.



	Cm	Inches
<b>S</b>	50,5 x 53 x 38,5	20" x 21" x 15¼"
<b>M</b>	68 x 71 x 33,5	27" x 28" x 13¼"
<b>L</b>	87 x 91 x 28,5	34½" x 36" x 11¼"
<b>XL</b>	101 x 106 x 23,5	40" x 41¾" x 9½"

For technical drawing / p. 346

Pricelist 2023 / p. 139  
Homescapes, embracing beauty / p. 25  
Homescapes, intimate portraits / pp. 17, 23  
Homescapes, gentle attitude / pp. 52, 53, 92, 93

## PIANO/TOP



**Pelle fard**  
nei colori del campionario  
Fard leather as per samples



**Marmo lucido naturale**  
Calacatta Vagli Oro  
Natural polished  
Calacatta Vagli Oro marble

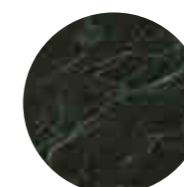

**Marmo lucido naturale**  
Verde Alpi  
Natural polished  
Verde Alpi marble



**Marmo spazzolato**  
Fior di Pesco  
Brushed Fior di Pesco  
marble



**Legno tinto nero a poro aperto**  
rivestito con fascia zigrinata  
Black open pore stained wood  
covered by hand-knurled border part

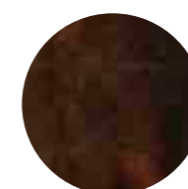

**Legno verniciato**  
"Rosso Marte"  
Wood painted  
"Rosso Marte"

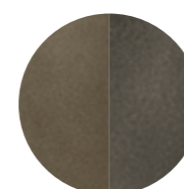

**Legno verniciato**  
Bronzo antico / Piombo  
Wood painted  
Antique bronze / Lead



**Legno spazzolato**  
"Cashmere" Gold Grey  
Natural polished  
brushed wood



**Legno spazzolato**  
"Cashmere" Anthracite  
Natural polished  
brushed wood



**Ottone brunito a mano**  
Hand burnished brass

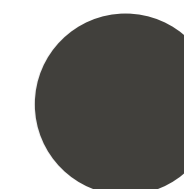

**Ottone brunito scuro**  
Dark burnished brass

## ZOCCOLO/PLINTH



▲ NOX  
Piani in cristallo trasparente / Struttura in acciaio inox lucido / Parti in legno rovere tinto wengé  
Transparent glass top / Stainless steel structure / Wengé stained wooden parts

# Nox

Ricardo Bello Dias / 2009

Tavolino in cristallo temperato 8mm. Piano superiore in cristallo trasparente.  
Piano inferiore in cristallo retroverniciato nei colori del campionario nella versione  
brillante o satinata.  
Struttura in acciaio inox o in metallo laccato color brunito con parti in legno in rovere  
sbiancato, tinto wengé, tinto tabacco o laccato nero a poro aperto.

Coffee table in 8mm tempered glass. Transparent glass top.  
Painted glass bottom as per samples in the bright or satin version.  
Stainless steel or burnished lacquered metal structure with whitened oak, wengé  
stained, tobacco stained or black open pore lacquered wooden parts.



## Cm

80 x 60 x 30  
80 x 80 x 30  
100 x 60 x 30  
100 x 80 x 30  
100 x 100 x 30  
60 x 60 x 50  
80 x 60 x 50  
80 x 80 x 50  
120 x 120 x 30  
80 x 140 x 30  
60 x 160 x 30

## Inches

31½" x 23¾" x 12"  
31½" x 31½" x 12"  
39½" x 23¾" x 12"  
39½" x 31½" x 12"  
39½" x 39½" x 12"  
23¾" x 23¾" x 19¾"  
31½" x 23¾" x 19¾"  
31½" x 31½" x 19¾"  
47¼" x 47¼" x 12"  
31½" x 55¼" x 12"  
23¾" x 63" x 12"

For technical drawing / p. 346

Pricelist 2023 / p. 140

## PIANO SUPERIORE/TOP



Cristallo trasparente  
Transparent glass

## PIANO INFERIORE/BOTTOM



Sample box

Cristallo brillante/satinato  
nei colori del campionario  
Glass bright/satin version  
as per samples

## STRUTTURA/STRUCTURE



Acciaio inox  
Stainless steel

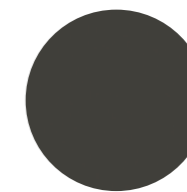

Metallo laccato color  
brunito  
Burnished lacquered metal

## PARTI IN LEGNO/WOODEN PARTS



Rovere sbiancato  
Whitened oak



Rovere tinto wengé  
Wengé stained oak



Rovere tinto tabacco  
Tobacco stained oak

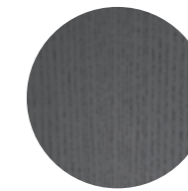

Rovere laccato nero a poro aperto  
Black open pore lacquered oak

# Oto Mini

Oscar e Gabriele Buratti / 2015

Tavolino con piano in cristallo bisellato (25mm) e retroverniciato nei colori nero, blu grigio e liquirizia nella versione brillante o satinata. Struttura in metallo verniciato lucido.  
Disponibile anche nella versione con piano in cristallo e struttura in metallo verniciati bronzo patinato.

## NOTE TECNICHE SUI MATERIALI

**CRISTALLO** | Le finiture esclusive risultato della lavorazione manuale realizzata sul cristallo possono presentare striature e differenze cromatiche. Queste caratteristiche non devono essere considerate difetti ma elementi distintivi del processo artigianale che esaltano la bellezza e la peculiarità del pezzo unico.

Coffee table with bevelled (25mm) and painted glass top in the colours black, blue grey and liquorice in the bright or satin version. Bright lacquered metal structure.  
Also available version with patinated bronze painted glass top and metal structure.

## TECHNICAL INFORMATION ON THE MATERIALS

**GLASS** | Exclusive finishes, resulting from the craftsmanship on the glass, may show streaks and chromatic differences. These characteristics should not be considered imperfections but distinctive evidence of the hand-made process that enhance the beauty and peculiarity of the unique piece



### Cm

Spessore 10mm  
Ø45 x 50

Spessore 15mm  
Ø90 x 32  
Ø90 x 42  
Ø100 x 32  
Ø100 x 42  
Ø120 x 32  
Ø120 x 42  
Ø130 x 32  
Ø130 x 42

### Inches

Thickness 10mm  
Ø17¾" x 19¾"

Thickness 15mm  
Ø35½" x 12¾"  
Ø35½" x 16¾"  
Ø39½" x 12¾"  
Ø39½" x 16¾"  
Ø47¼" x 12¾"  
Ø47¼" x 16¾"  
Ø51¼" x 12¾"  
Ø51¼" x 16¾"

For technical drawing / p. 346

Pricelist 2023 / p. 142  
Homescapes, intimate portraits / p. 107

## PIANO E STRUTTURA/TOP AND STRUCTURE

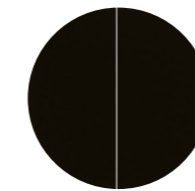

**Cristallo retroverniciato nero brillante/satinato**  
Bright/satin black painted glass

**Metallo verniciato nero lucido**  
Bright black lacquered metal

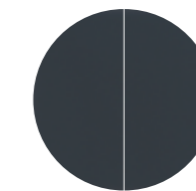

**Cristallo retroverniciato blu grigio brillante/satinato**  
Bright/satin blue grey painted glass

**Metallo verniciato blu grigio lucido**  
Bright blue grey lacquered metal



**Cristallo retroverniciato liquirizia brillante/satinato**  
Bright/satin liquorice painted glass

**Metallo verniciato liquirizia lucido**  
Bright liquorice lacquered metal

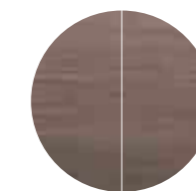

**Cristallo verniciato bronzo patinato**  
Patinated bronze painted glass

**Metallo verniciato bronzo patinato**  
Patinated bronze lacquered metal

### ▲ OTO MINI

Piano in cristallo bisellato e retroverniciato blu-grigio brillante / Struttura in metallo blu-grigio lucido  
Bevelled and bright blue-grey painted glass top / Blue-grey bright lacquered metal structure

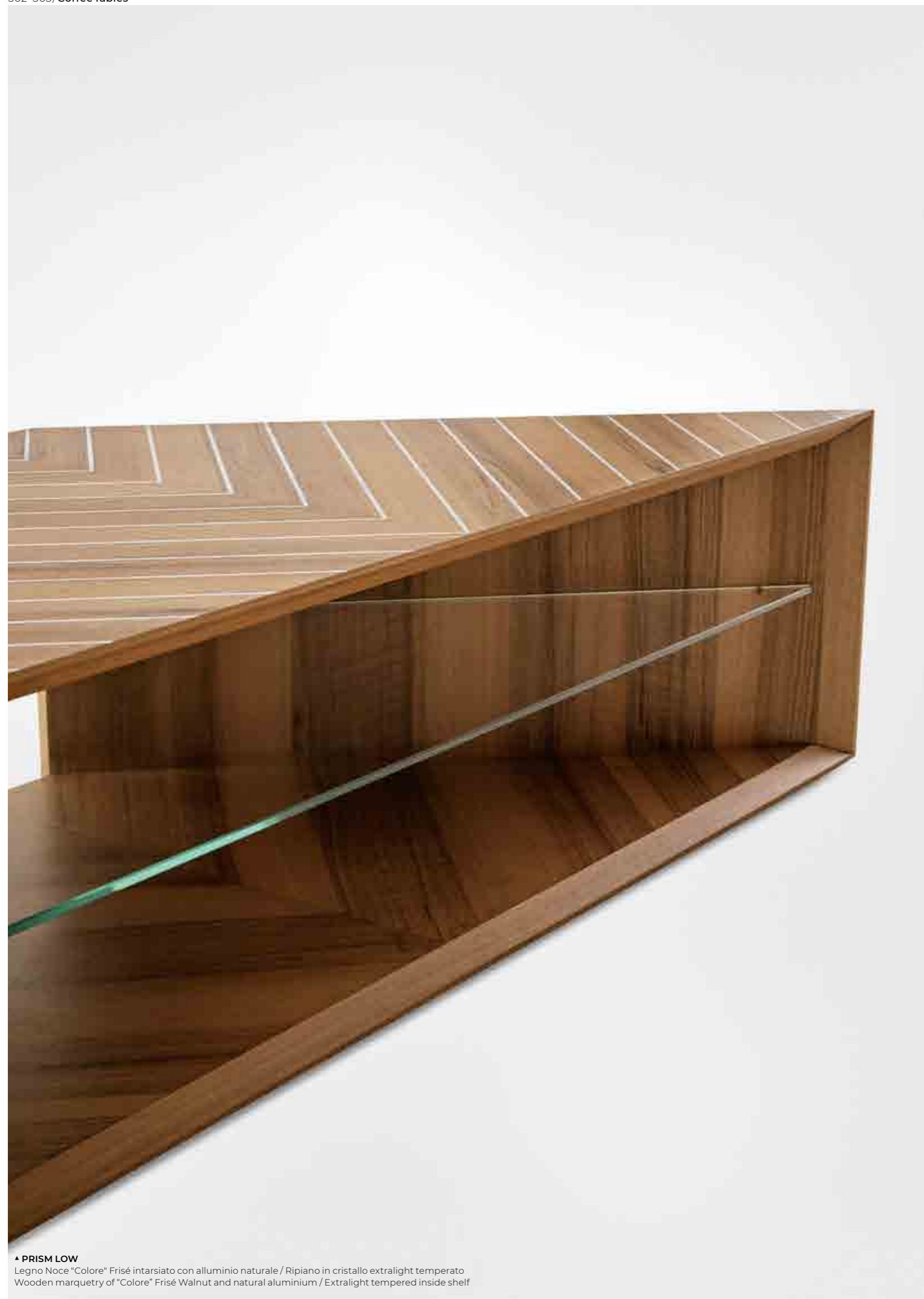

▲ **PRISM LOW**  
 Legno Noce "Colore" Frisé intarsiato con alluminio naturale / Ripiano in cristallo extralight temperato  
 Wooden marquetry of "Colore" Frisé Walnut and natural aluminium / Extralight tempered inside shelf

# Prism Low

david/nicolas / 2020

Tavolino in legno Noce "Colore" Frisé intarsiato con alluminio naturale o Palissandro India intarsiato con alluminio naturale. Versione h.37 cm dotata di ripiano interno in cristallo extralight temperato 8 mm. Versione h. 23/31/40/47 cm disponibile sia in Travertino Romano spazzolato naturale (non resinato) che in marmo Verde Alpi lucido naturale.

! Il legno è un materiale vivo che subisce un naturale processo di ossidazione che può causare cambiamenti cromatici. Venature e tonalità di colore differenti delle lastre non sono da considerarsi come difetti, ma caratteristiche che esaltano l'unicità del materiale.

## NOTE TECNICHE SUI MATERIALI

**INTARSIO** | L'intarsio è una tecnica di lavorazione artigianale utilizzata per ottenere un particolare disegno e si realizza accostando elementi di materiali differenti (come legno e alluminio) oppure dello stesso materiale. Questa lavorazione rende il prodotto unico ed esclusivo. Le eventuali variazioni cromatiche e di venatura del legno sono da considerarsi caratteristiche del materiale stesso e non possono essere controllate.

**TRAVERTINO/MARMO** | Il marmo è un materiale naturale di origine sedimentaria che può presentare particolarità come venature, lievi irregolarità superficiali, colorazioni differenti e cristallizzazioni. Queste peculiarità sono da attribuirsi alla naturalezza del materiale e non sono da considerarsi difetti ma caratteristiche tipiche del marmo. Ogni prodotto risulterà unico, esclusivo e non replicabile. I nostri marmi (escluso il Travertino Romano) vengono trattati con un prodotto idrorepellente che permette una maggiore protezione della superficie stessa, aumentando l'impermeabilità. Questo trattamento non esclude la vulnerabilità del marmo alle sostanze acide.

Wooden coffee table with marquetry of "Colore" Frisé Walnut and natural aluminium or India Rosewood and natural aluminium. 37 cm h. version supplied with 8 mm thick extralight tempered inside shelf. 23/31/40/47 cm h. version available in either natural brushed Travertino Romano (not treated with resin) or natural polish Verde Alpi marble.

! Wood is a living material and the natural oxidation process can cause chromatic changes. Different grain and colour shades of the wooden slabs are not to be considered as defects, but characteristics that enhance the uniqueness of the material.

## TECHNICAL INFORMATION ON THE MATERIALS

**INLAY** | Inlay is an artisanal technique used to obtain a particular design and is made by combining elements of different materials (such as wood and aluminium) or of the same material. This process makes the product unique and exclusive. Any colour and grain variations of the wood are to be considered as characteristics of the material itself and cannot be controlled.

**TRAVERTINO/MARBLE** | The marble is a natural material of sedimentary origin that can present particularities such as veins, slight surface irregularities, different colors and crystallizations. These peculiarities are to be attributed to the naturalness of the material and are not to be considered defects but typical characteristics of marble. Each product will be unique, exclusive and non-replicable. Our marbles (excluded Travertino Romano) are treated with water-repellent products which affords greater protection to the surface of the marble, improving its impermeability. This treatment doesn't exclude the vulnerability of the marble to acid substances.



### Cm

**Marmo**  
 40 x 40 x 40  
 40 x 40 x 47  
 65 x 64 x 31  
 93 x 91 x 23

### Legno

117,5 x 47 x 30  
 117,5 x 47 x 37  
 141,5 x 59 x 30  
 141,5 x 59 x 37

### Inches

**Marble**  
 15¾" x 15¾" x 15¾"  
 15¾" x 15¾" x 18¾"  
 25¾" x 25¾" x 12¾"  
 36¾" x 36" x 9¾"

### Wood

46½" x 18¾" x 12"  
 46½" x 18¾" x 14¾"  
 55¾" x 23¾" x 12"  
 55¾" x 23¾" x 14¾"

[For technical drawing / p. 347](#)

[Pricelist 2023 / p. 143](#)  
[Homescapes, embracing beauty / p. 82](#)  
[Homescapes, intimate portraits / p. 53](#)  
[Homescapes, gentle attitude / pp. 48, 72, 73, 76, 79, 98, 100](#)

## STRUTTURA/STRUCTURE

VERSIONE 37 CM



**Legno Noce "Colore" Frisé e alluminio naturale**  
 "Colore" Frisé Walnut and aluminium

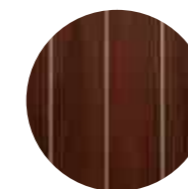

**Legno palissandro India e alluminio naturale**  
 India rosewood and aluminium



**Marmo Verde Alpi lucido naturale**  
 Natural polish Verde Alpi marble



**Travertino Romano spazzolato naturale**  
 Natural brushed Travertino Romano



**Cristallo extralight**  
 Extralight glass

## STRUTTURA/STRUCTURE

VERSIONE 40-47 CM

## RIPIANO INTERNO/INSIDE SHELF

VERSIONE 37 CM



# Raj 1

Ricardo Bello Dias / 2006

Tavolino con piano in cristallo temperato trasparente o extralight 12mm.  
Struttura in acciaio inox lucido (profilo 40x20x2mm).  
Giunto centrale in alluminio cromato.  
Disponibile con piano in cristallo 12mm temperato "grigio Italia" e struttura in metallo laccato color brunito.

Coffee table with 12mm tempered transparent or extralight glass top.  
Bright stainless steel base (40x20x2mm).  
Chromed aluminium central part.  
Also available with 12mm tempered smoked "grigio Italia" glass top and burnished lacquered metal structure.



#### Cm

Ø100 x 27  
Ø100 x 37  
Ø120 x 27  
Ø120 x 37  
Ø140 x 27  
Ø140 x 37

#### Inches

Ø39½" x 10¾"  
Ø39½" x 14¾"  
Ø47¼" x 10¾"  
Ø47¼" x 14¾"  
Ø55¼" x 10¾"  
Ø55¼" x 14¾"

[For technical drawing / p.347](#)

[Pricelist 2023 / p.144](#)

#### PIANO/TOP



**Cristallo trasparente**  
Transparent glass



**Cristallo extralight**  
Extralight glass



**Cristallo "grigio Italia"**  
"Grigio Italia" glass

#### STRUTTURA/STRUCTURE



**Acciaio inox lucido**  
Bright stainless steel

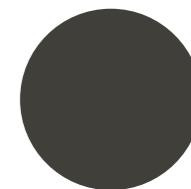

**Metallo laccato color  
brunito**  
Burnished lacquered metal

#### ▲ RAJ1

Piano in cristallo extralight temperato / Struttura in acciaio inox lucido  
Transparent tempered glass top / Bright stainless steel base

# Raj 2

Ricardo Bello Dias / 2006

Tavolino con piano in cristallo trasparente o extralight 10mm.  
Struttura in acciaio inox lucido (profilo 20x20x1,5mm).  
Giunto centrale in alluminio cromato.  
Disponibile con piano in cristallo "grigio Italia" 10mm e struttura in metallo laccato color brunito.

Coffee table with 10mm transparent or extralight glass top.  
Bright stainless steel base (20x20x1,5 mm).  
Chromed aluminium central part.  
Also available with 10mm smoked "grigio Italia" glass top and burnished lacquered metal structure.



	Cm	Inches
<b>S</b>	Ø40 x 40	Ø15¾" x 15¾"
<b>M</b>	Ø45 x 45	Ø17¾" x 17¾"
<b>L</b>	Ø50 x 50	Ø19¾" x 19¾"
<b>XL</b>	Ø70 x 33	Ø27¾" x 13"
<b>XXL</b>	Ø80 x 23	Ø31½" x 9¼"

For technical drawing / p. 348

Pricelist 2023 / p. 145

## PIANO/TOP



**Cristallo trasparente**  
Transparent glass



**Cristallo extralight**  
Extralight glass



**Cristallo "grigio Italia"**  
"Grigio Italia" glass

## STRUTTURA/STRUCTURE



**Acciaio inox lucido**  
Bright stainless steel

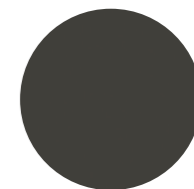

**Metallo laccato color brunito**  
Burnished lacquered metal

▲ **RAJ 2**  
Piano in cristallo extralight temperato / Struttura in acciaio inox lucido  
Transparent tempered glass top / Bright stainless steel base



▲ **RAJ 3**  
Piano in cristallo extralight temperato / Struttura in acciaio inox lucido  
Transparent tempered glass top / Bright stainless steel base

# Raj 3

Ricardo Bello Dias / 2011

Tavolino con piano in cristallo temperato trasparente o extralight 8mm.  
Struttura in acciaio inox lucido (profilo 20x20x1,5 mm).  
Giunto centrale in alluminio cromato.  
Disponibile con piano in cristallo temperato "grigio Italia" 8mm e struttura in metallo laccato color brunito.

Coffee table with 8mm tempered transparent or extralight glass top.  
Bright stainless steel base (20x20x1,5mm).  
Chromed aluminium central part.  
Also available with 8mm tempered smoked "grigio Italia" glass top and burnished lacquered metal structure.

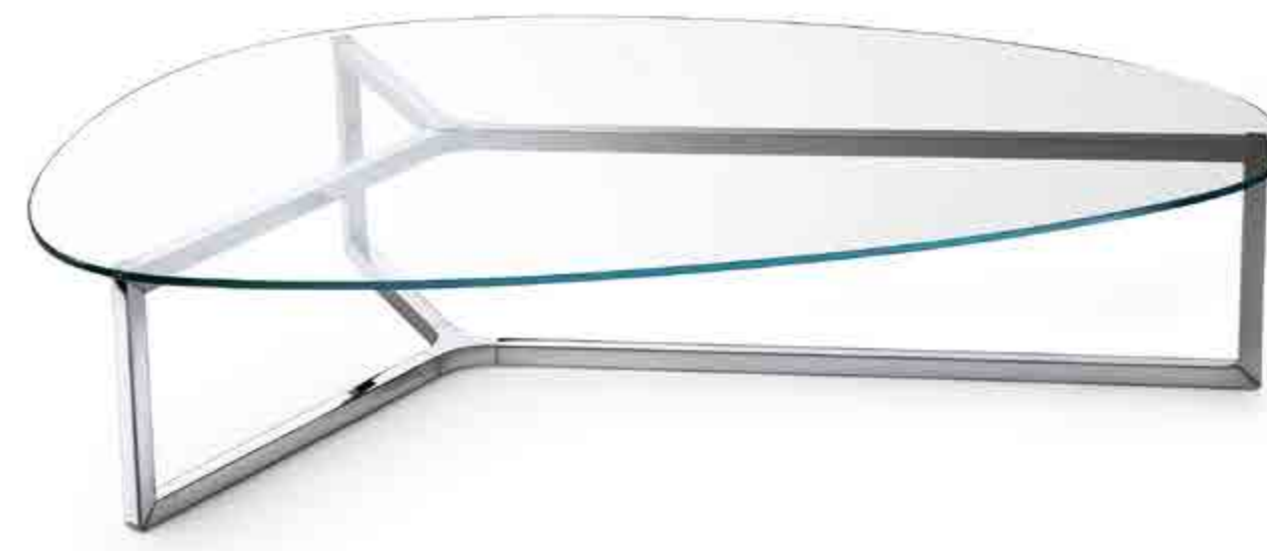

	Cm	Inches
S	69 x 44 x 40	27 <sup>1</sup> / <sub>4</sub> " x 17 <sup>1</sup> / <sub>2</sub> " x 15 <sup>3</sup> / <sub>4</sub> "
M	86 x 56 x 33	34" x 22 <sup>1</sup> / <sub>4</sub> " x 13"
L	108 x 70 x 23	43 <sup>3</sup> / <sub>4</sub> " x 27 <sup>3</sup> / <sub>4</sub> " x 9 <sup>1</sup> / <sub>4</sub> "

For technical drawing / p. 348

Pricelist 2023 / p. 146

## PIANO/TOP



Cristallo trasparente  
Transparent glass



Cristallo extralight  
Extralight glass



Cristallo "grigio Italia"  
"Grigio Italia" glass

## STRUTTURA/STRUCTURE



Acciaio inox lucido  
Bright stainless steel

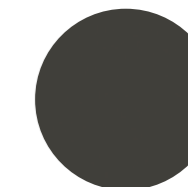

Metallo laccato color  
brunito  
Burnished lacquered metal

# Raj 6

Ricardo Bello Dias / 2013

Tavolino con piano in cristallo temperato "grigio Italia" 10mm e struttura in metallo laccato color brunito.  
Disponibile con piano in cristallo temperato trasparente o extralight 10mm e struttura in acciaio inox lucido.

Coffee table with 10mm smoked "grigio Italia" tempered glass top and burnished lacquered metal structure.  
Also available with 10mm tempered transparent or extralight glass top and structure in bright stainless steel.



## Cm

120 x 70 x 23  
140 x 70 x 23  
160 x 70 x 23  
120 x 70 x 33  
140 x 70 x 33  
160 x 70 x 33  
140 x 40 x 40  
160 x 40 x 40  
180 x 40 x 40

## Inches

47 3/4" x 27 3/4" x 9 1/4"  
55 1/4" x 27 3/4" x 9 1/4"  
63" x 27 3/4" x 9 1/4"  
47 1/4" x 27 3/4" x 13"  
55 1/4" x 27 3/4" x 13"  
63" x 27 3/4" x 13"  
55 1/4" x 15 3/4" x 15 3/4"  
63" x 15 3/4" x 15 3/4"  
71" x 15 3/4" x 15 3/4"

[For technical drawing / p. 348](#)

[Pricelist 2023 / p. 147](#)

## ▲ RAJ 6

Piano in cristallo "grigio Italia" temperato / Struttura in metallo laccato color brunito  
"Grigio Italia" tempered glass top / Burnished lacquered metal structure

## PIANO/TOP



Cristallo "grigio Italia"  
"Grigio Italia" glass



Cristallo trasparente  
Transparent glass



Cristallo extralight  
Extralight glass

## STRUTTURA/STRUCTURE

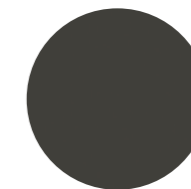

Metallo laccato color  
brunito  
Burnished lacquered metal

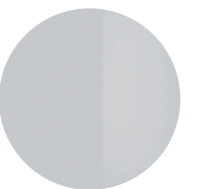

Acciaio inox lucido  
Bright stainless steel



▲ RE-VERRE  
Melange "terre"

# Re-verre

Federica Biasi / 2023

Tavolino monomaterico in vetro riciclato disponibile nella finitura "melange terre" (arancio "terre cuite", marrone "noisette" e marrone "chocolat") con basamento marrone "chocolat" o "melange lunaire" (bianco "blanc", beige "sable" e grigio "roche") con basamento grigio "roche".

Trattandosi di una lavorazione artigianale e manuale le misure sono indicative e la superficie potrebbe essere porosa e non essere completamente planare.

## NOTE TECNICHE SUI MATERIALI

**FINITURE ARTIGIANALI** | Le finiture manuali ed esclusive, risultato del processo di ossidazione di foglia argento, oro e rame, possono presentare macchie e striature, oltre a differenze cromatiche. Tali disomogeneità sono caratteristiche che non devono essere considerate difetti ma elementi distintivi, tipici dell'ossidazione manuale, che esaltano la bellezza e la peculiarità del pezzo unico.

Coffee table in recycled glass available in the following finishes: "melange terre" ("terre cuite" orange, "noisette" brown and "chocolat" brown) with "chocolat" brown base or "mélange lunaire" ("blanc" white, "sable" beige and "roche" grey) with "roche" grey base.

Since this is an artisanal and manual process, the measurements are indicative and the surface may be porous and not completely flat.

## TECHNICAL INFORMATION ON THE MATERIALS

**ARTISANAL FINISHES** | Artisanal and exclusive finishes that are obtained from the oxidation of silver, gold and copper leaves may show marks and spots, as well as variations in colour. These differences are inevitable and should not be considered imperfections but evidence of the hand-crafted process. They enhance the beauty and distinctiveness of a unique piece.



## Cm

Ø50 x 50  
Ø60 x 47  
Ø90 x 37  
Ø120 x 27

## Inches

Ø19¾" x 19¾"  
Ø23¾" x 18¾"  
Ø35½" x 14¾"  
Ø47¾" x 10¾"

[For technical drawing / p. 349](#)

[Pricelist 2023 / p. 148](#)

## STRUTTURA/STRUCTURE

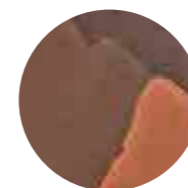

Vetro riciclato  
"melange terre"  
recycled glass

Arancione "terre cuite"  
"Terre cuite" orange

Marrone "noisette"  
"Noisette" brown

Marrone "chocolat"  
"Chocolat" brown



Vetro riciclato  
"melange lunaire"  
recycled glass

Bianco "blanc"  
"Blanc" white

Beige "sable"  
"Sable" beige

Grigio "roche"  
"Roche" grey



• RE-VERRE  
Mélange "lunaire"





# Selce

Studiopepe / 2023

Tavolino in pietra. Disponibile nella finitura "Ceppo dei Volpi" o "Ceppo Antico". Disponibile anche in Travertino Romano spazzolato naturale (non resinato). Versione destra o sinistra (A e C) da specificare al momento dell'ordine.

Coffee table in stone. Available in "Ceppo dei Volpi" or "Ceppo Antico". Also available in natural brushed Travertino Romano (not treated with resin). Right or left version (A and C) to be specified when ordering.

## NOTE TECNICHE SUI MATERIALI

**MARMO** | Il marmo è un materiale naturale di origine sedimentaria che può presentare particolarità come venature, lievi irregolarità superficiali, colorazioni differenti e cristallizzazioni. Queste peculiarità sono da attribuirsi alla naturalezza del materiale e non sono da considerarsi difetti ma caratteristiche tipiche del marmo. Ogni prodotto risulterà unico, esclusivo e non replicabile. I nostri marmi vengono trattati con un prodotto idrorepellente che permette una maggiore protezione della superficie stessa, aumentando l'impermeabilità. Questo trattamento non esclude la vulnerabilità del marmo alle sostanze acide.

## TECHNICAL INFORMATION ON THE MATERIALS

**MARBLE** | The marble is a natural material of sedimentary origin that can present particularities such as veins, slight surface irregularities, different colors and crystallizations. These peculiarities are to be attributed to the naturalness of the material and are not to be considered defects but typical characteristics of marble. Each product will be unique, exclusive and non-replicable. Our marbles are treated with water-repellent products which affords greater protection to the surface of the marble, improving its impermeability. This treatment doesn't exclude the vulnerability of the marble to acid substances.



### Cm

A 85 x 68 x 36,4  
B Ø50 x 50,4  
C 136 x 70 x 30,8

### Inches

33½" x 27" x 14½"  
Ø19¾" x 20¾"  
53¾" x 27¾" x 12"

[For technical drawing / p. 349](#)

[Pricelist 2023 / p. 149](#)

## STRUTTURA/STRUCTURE



"Ceppo dei Volpi"  
"Ceppo de Volpi"



"Ceppo Antico"  
"Ceppo Antico"



Travertino Romano  
spazzolato naturale  
Natural brushed  
Travertino Romano



▲ SENSEI  
Piano legno laccato "deep black", cristallo "Rosso Marte", marmo Calacatta Vagli Oro  
"Deep black lacquered wood, "Rosso Marte" glass, Natural polished Calacatta Vagli Oro marble

# Sensei

Tollgard + Castellani / 2022

Tavolino con struttura in metallo e piano in legno laccato "deep black". In appoggio sul top in legno, piano in cristallo 12mm molato a mezzo toro nella finitura esclusiva "Rosso Marte" oppure retroverniciato brillante nei colori del campionario. Disponibile anche piano in marmo 20mm Calacatta Vagli Oro lucido naturale, Ceppo di Gré® spazzolato, Arabescato Orobico Rosso satinato, Bianco Carrara Gioia satinato oppure Dover White satinato. Il tavolino "A" viene realizzato esclusivamente con piano in legno ribassato.

Coffee table with "deep black" lacquered metal structure and wooden top. Resting on the wooden top, 12mm glass top with half bull-nose grinding in the exclusive finish "Rosso Marte" or painted as per samples in the bright version. Also available with 20mm natural polished Calacatta Vagli Oro marble, brushed Ceppo di Gré®, satin Arabescato Orobico Rosso, satin Bianco Carrara Gioia or satin Dover White. The coffee table A is made exclusively with recessed wooden top.

## NOTE TECNICHE SUI MATERIALI

**MARMO** | Il marmo è un materiale naturale di origine sedimentaria che può presentare particolarità come venature, lievi irregolarità superficiali, colorazioni differenti e cristallizzazioni. Queste peculiarità sono da attribuirsi alla naturalezza del materiale e non sono da considerarsi difetti ma caratteristiche tipiche del marmo. Ogni prodotto risulterà unico, esclusivo e non replicabile. I nostri marmi vengono trattati con un prodotto idrorepellente che permette una maggiore protezione della superficie stessa, aumentando l'impermeabilità. Questo trattamento non esclude la vulnerabilità del marmo alle sostanze acide.

## TECHNICAL INFORMATION ON THE MATERIALS

**MARBLE** | The marble is a natural material of sedimentary origin that can present particularities such as veins, slight surface irregularities, different colors and crystallizations. These peculiarities are to be attributed to the naturalness of the material and are not to be considered defects but typical characteristics of marble. Each product will be unique, exclusive and non-replicable. Our marbles are treated with water-repellent products which affords greater protection to the surface of the marble, improving its impermeability. This treatment doesn't exclude the vulnerability of the marble to acid substances.



### Cm

#### Piano in legno

A | 130 x 25 x 43

#### Piano in cristallo

B | 160 x 25 x 34,5

C | 180 x 45 x 34,5

D | 140 x 85 x 24,5

E | Ø45 x 42,1

F | Ø100 x 24,1

G | Ø100 x 34,6

#### Piano in marmo

B | 160 x 25 x 35

C | 180 x 45 x 35

D | 140 x 85 x 25

E | Ø45 x 42,9

F | Ø100 x 24,9

G | Ø100 x 35,4

### Inches

#### Wooden top

A | 51¼" x 10" x 17"

#### Glass top

B | 63" x 10" x 13¾"

C | 71" x 17¾" x 13¾"

D | 55½" x 33½" x 9¾"

E | 17¾" x 16¾"

F | 39½" x 9½"

G | 39½" x 13¾"

#### Marble top

B | 63" x 10" x 14"

C | 71" x 17¾" x 14"

D | 55½" x 33½" x 10"

E | Ø17¾" x 17"

F | Ø39½" x 10"

G | Ø39½" x 10"

For technical drawing / p. 350

Pricelist 2023 / p. 150

Homescapes, gentle attitude / pp. 36, 39, 72, 74

## PIANO/TOP



Legno laccato "deep black"  
"deep black" lacquered wood



Cristallo "Rosso Marte"  
"Rosso Marte" glass



Cristallo brillante  
nei colori del campionario  
Bright glass version  
as per samples



Marmo lucido naturale  
Calacatta Vagli Oro  
Natural polished Calacatta  
Vagli Oro marble

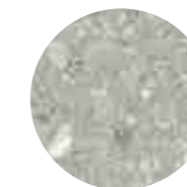

Ceppo di Gré® spazzolato  
Brushed Ceppo di Gré®



Marmo Arabescato  
Orobico Rosso satinato  
Arabescato Orobico  
Rosso satin marble

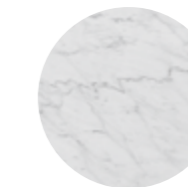

Marmo spazzolato  
Bianco Carrara Gioia  
Brushed Bianco Carrara  
Gioia marble

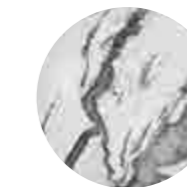

Marmo satinato  
Dover white  
Satin Dover white marble

## STRUTTURA/STRUCTURE



Metallo laccato  
"deep black"  
"deep black" lacquered metal





▲ **SIR T 32**  
Piano in cristallo trasparente temperato / Struttura in ottone satinato  
Transparent tempered glass top / Satin brass metal structure

# Sir T 32/Sir T32 C

Pierangelo Gallotti / 1971

Tavolino con piano in cristallo trasparente, extralight o "grigio Italia" temperato 10mm. Coffee table with 10mm transparent, extralight or smoked "grigio Italia" tempered glass top. Chromed brass structure. Bright or satin brass metal parts, on request.  
Struttura in ottone cromato. A richiesta ottone lucido o satinato.



#### Cm

80 x 80 x 33  
100 x 100 x 33  
120 x 60 x 33  
120 x 120 x 33  
140 x 60 x 33  
140 x 80 x 33

**Sir T/32C**  
40 x 45 x 51

#### Inches

31½" x 31½" x 13"  
39½" x 39½" x 13"  
47¼" x 23¾" x 13"  
47¼" x 47¼" x 13"  
55½" x 23¾" x 13"  
55½" x 31½" x 13"

**Sir T/32C**  
15¾" x 17¾" x 20¼"

For technical drawing / p. 351

Pricelist 2023 / p. 152

#### PIANO/TOP



**Cristallo trasparente**  
Transparent glass



**Cristallo extralight**  
Extralight glass



**Cristallo "grigio Italia"**  
"Grigio Italia" glass



**Ottone cromato**  
Chrome



**Ottone lucido**  
Bright brass



**Ottone satinato**  
Satin brass

#### STRUTTURA/STRUCTURE

# T 33

Pierangelo Gallotti / 1982

Tavolino con piano in cristallo temperato trasparente 10 mm.  
Disponibile anche in cristallo temperato extralight o "grigio Italia" 10mm. Parti  
metalliche in acciaio inox lucido.  
A richiesta acciaio inox satinato, ottone lucido, satinato o laccato bianco o nero  
goffrato.

Coffee table with 10mm transparent tempered glass top.  
Also available with 10mm extralight or smoked "grigio Italia" tempered glass.  
Bright stainless steel metal parts. Satin stainless steel or bright, satin brass or  
embossed white or black lacquered metal parts on request.



## Cm

58 x 30 x 30  
63 x 30 x 36  
80 x 80 x 42  
100 x 60 x 42  
100 x 100 x 42  
100 x 100 x 42  
120 x 60 x 42  
120 x 80 x 42  
140 x 80 x 42

## Inches

23" x 12" x 12"  
25" x 12" x 14 1/4"  
31 1/2" x 31 1/2" x 16 3/4"  
39 1/2" x 23 3/4" x 16 3/4"  
39 1/2" x 39 1/2" x 7 1/4"  
39 1/2" x 39 1/2" x 16 3/4"  
47 1/4" x 23 3/4" x 16 3/4"  
47 1/4" x 31 1/2" x 16 3/4"  
55 1/4" x 31 1/2" x 16 3/4"

For technical drawing / p. 351

Pricelist 2023 / p. 154

## PIANO/TOP



**Cristallo trasparente**  
Transparent glass



**Cristallo "grigio Italia"**  
Smoked "grigio Italia" glass



**Cristallo extralight**  
Extralight glass

## PARTI METALLICHE/METAL PARTS



**Acciaio inox lucido**  
Bright stainless steel

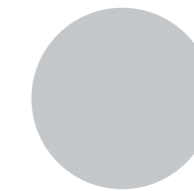

**Acciaio inox satinato**  
Satin stainless steel

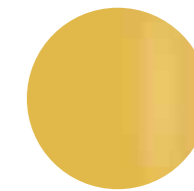

**Ottone lucido**  
Bright brass



**Ottone satinato**  
Satin brass

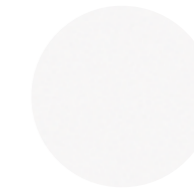

**Laccato bianco goffrato**  
Embossed white lacquered



**Laccato nero goffrato**  
Embossed black lacquered

## ▲ T 33

Piano in cristallo trasparente temperato / Parti metalliche in acciaio inox lucido  
Transparent tempered glass top / Bright stainless steel metal parts

# T 35 R

Pierangelo Gallotti / 1975

Serie di 3 tavolini in cristallo trasparente temperato 8mm.  
Disponibile anche in cristallo temperato extralight o "grigio Italia" 8mm.  
Parti metalliche in acciaio inox lucido.  
A richiesta acciaio inox satinato, ottone lucido, satinato o laccato bianco o nero goffrato.

Set of three coffee tables in 8mm transparent tempered glass.  
Also available in 8mm extralight or smoked "grigio Italia" tempered glass.  
Bright stainless steel metal parts. Satin stainless steel or bright, satin brass or embossed white or black lacquered metal parts on request.



## Cm

35 x 40 x 39  
80 x 40 x 42  
**Set** 80 x 40 x 42  
45 x 50 x 39  
100 x 50 x 42  
**Set** 100 x 50 x 42

## Inches

14" x 15 3/4" x 15 1/2"  
31 1/2" x 15 3/4" x 16 3/4"  
**Set** 31 1/2" x 15 3/4" x 16 3/4"  
17 3/4" x 19 3/4" x 15 1/2"  
39 1/2" x 19 3/4" x 16 3/4"  
**Set** 39 1/2" x 19 3/4" x 16 3/4"

[For technical drawing / p. 351](#)

[Pricelist 2023 / p. 156](#)

## PIANO/TOP



**Cristallo trasparente**  
Transparent glass



**Cristallo "grigio Italia"**  
Smoked "grigio Italia" glass



**Cristallo extralight**  
Extralight glass

## PARTI METALLICHE/METAL PARTS



**Acciaio inox lucido**  
Bright stainless steel

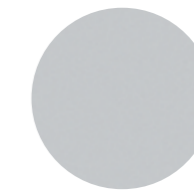

**Acciaio inox satinato**  
Satin stainless steel

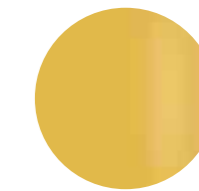

**Ottone lucido**  
Bright brass



**Ottone satinato**  
Satin brass

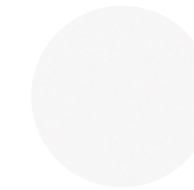

**Laccato bianco goffrato**  
Embossed white lacquered

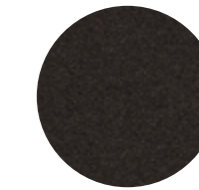

**Laccato nero goffrato**  
Embossed black lacquered

## ▲ T 35 R

Piano in cristallo trasparente temperato / Parti metalliche in acciaio inox lucido  
Transparent tempered glass top / Bright stainless steel metal parts



▲ **T 35 TRIO**  
Piano in cristallo trasparente temperato / Parti metalliche in acciaio inox lucido  
Transparent tempered glass top / Bright stainless steel metal parts

# T 35 Trio

Pierangelo Gallotti / 1975

Serie di 3 tavolini in cristallo trasparente temperato 8mm.  
Disponibile anche in cristallo temperato extralight o "grigio Italia" 8mm.  
Parti metalliche in acciaio inox lucido.  
A richiesta acciaio inox satinato, ottone brillante, satinato o laccato bianco o nero goffrato.

Set of three coffee tables in 8mm transparent tempered glass.  
Also available in 8mm extralight or smoked "grigio Italia" tempered glass.  
Bright stainless steel metal parts.  
Satin stainless steel, bright, satin brass or embossed white or black lacquered metal parts on request.

## Cm

38 x 40 x 36  
43 x 40 x 39  
48 x 40 x 42  
**Set** 48 x 40 x 42

## Inches

15" x 15¾" x 14¼"  
17" x 15¾" x 15½"  
19" x 15¾" x 16¾"  
**Set** 19" x 15¾" x 16¾"

[For technical drawing / p. 352](#)

[Pricelist 2023 / p. 158](#)

## PIANO/TOP



**Cristallo trasparente**  
Transparent glass



**Cristallo "grigio Italia"**  
Smoked "grigio Italia" glass



**Cristallo extralight**  
Extralight glass

## PARTI METALLICHE/METAL PARTS



**Acciaio inox lucido**  
Bright stainless steel

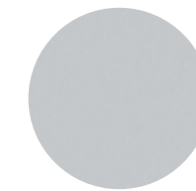

**Acciaio inox satinato**  
Satin stainless steel

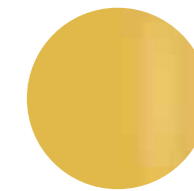

**Ottone lucido**  
Bright brass



**Ottone satinato**  
Satin brass

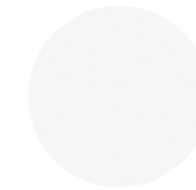

**Laccato bianco goffrato**  
Embossed white lacquered

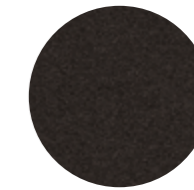

**Laccato nero goffrato**  
Embossed black lacquered

# Tetris

Massimo Castagna / 2014

Tavolino in cristallo temperato 6mm stopsol bronzo, extralight o retroverniciato nero brillante. Struttura in ottone brunito a mano.  
L'ottone risulta naturalmente macchiato e disomogeneo.  
Questa lavorazione artigianale conferisce ad ogni pezzo una particolare unicità, rendendolo esclusivo. Non realizzabile su misura.

Coffee table in 6mm bronze stopsol, extralight or bright black painted tempered glass.  
Structure in hand burnished brass.  
The hand burnished brass finish looks naturally spotted and irregular.  
Due to this craftmade processing, each product is unique and exclusive. Not available in custom size.

## NOTE TECNICHE SUI MATERIALI

**OTTONE BRUNITO A MANO** | L'ottone brunito a mano è ottenuto da un processo di ossidazione naturale eseguito manualmente. Il risultato di questa lavorazione è un prodotto che può presentare macchie e variazioni di colore che non sono da considerarsi imperfezioni ma caratteristiche che conferiscono ad ogni pezzo una particolare unicità, rendendolo esclusivo.

## TECHNICAL INFORMATION ON THE MATERIALS

**HAND BURNISHED BRASS** | The hand burnished brass is the consequence of hand-made process of natural oxidation. The result of this processing is a product that may show marks and colour variations. These differences are inevitable and should not be considered imperfections but distinctive features due to this craftmade processing, each product is unique and exclusive.



### Cm

35 x 35 x 25  
35 x 35 x 35  
35 x 35 x 40  
35 x 45 x 40  
70 x 35 x 35  
70 x 70 x 30

### Inches

14" x 14" x 10"  
14" x 14" x 14"  
14" x 14" x 15 3/4"  
14" x 17 3/4" x 15 3/4"  
27 3/4" x 14" x 14"  
27 3/4" x 27 3/4" x 12"

For technical drawing / p. 352

Pricelist 2023 / p. 159

▲ **TETRIS**  
Piano in cristallo temperato stopsol bronzo / Piano in cristallo retroverniciato nero brillante  
Bronze Stopsol tempered glass top / Bright black painted tempered glass top

## PIANO/TOP



Cristallo stopsol bronzo  
Bronze stopsol glass



Cristallo extralight  
Extralight glass

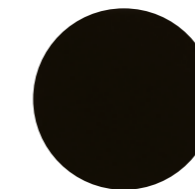

Cristallo retroverniciato  
nero brillante  
Bright black painted  
tempered glass.

## STRUTTURA/STRUCTURE

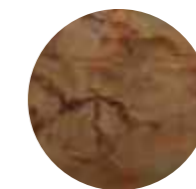

Ottone brunito a mano  
Hand burnished brass



# Twelve

Massimo Castagna / 2016

Tavolino con piano in marmo lucido naturale Calacatta Vagli Oro oppure con ciotola in ottone lucido. Struttura in ottone brunito a mano.

Coffee table with natural polished Calacatta Vagli Oro marble top or with bright brass plate. Hand burnished brass structure.

## NOTE TECNICHE SUI MATERIALI

**MARMO** | Il marmo è un materiale naturale di origine sedimentaria che può presentare particolarità come venature, lievi irregolarità superficiali, colorazioni differenti e cristallizzazioni. Queste peculiarità sono da attribuirsi alla naturalezza del materiale e non sono da considerarsi difetti ma caratteristiche tipiche del marmo. Ogni prodotto risulterà unico, esclusivo e non replicabile. I nostri marmi vengono trattati con un prodotto idrorepellente che permette una maggiore protezione della superficie stessa, aumentando l'impermeabilità. Questo trattamento non esclude la vulnerabilità del marmo alle sostanze acide.

**OTTONE BRUNITO A MANO** | L'ottone brunito a mano è ottenuto da un processo di ossidazione naturale eseguito manualmente. Il risultato di questa lavorazione è un prodotto che può presentare macchie e variazioni di colore che non sono da considerarsi imperfezioni ma caratteristiche che conferiscono ad ogni pezzo una particolare unicità, rendendolo esclusivo.

## TECHNICAL INFORMATION ON THE MATERIALS

**MARBLE** | The marble is a natural material of sedimentary origin that can present particularities such as veins, slight surface irregularities, different colors and crystallizations. These peculiarities are to be attributed to the naturalness of the material and are not to be considered defects but typical characteristics of marble. Each product will be unique, exclusive and non-replicable. Our marbles are treated with water-repellent products which affords greater protection to the surface of the marble, improving its impermeability. This treatment doesn't exclude the vulnerability of the marble to acid substances.

**HAND BURNISHED BRASS** | The hand burnished brass is the consequence of hand-made process of natural oxidation. The result of this processing is a product that may show marks and colour variations. These differences are inevitable and should not be considered imperfections but evidence of the hand-crafted process. They enhance the beauty and distinctiveness of a unique piece.



Cm	Inches
S Ø 19 x 48	Ø 7½" x 19"
M Ø 26 x 36	Ø 10¼" x 14¼"
L Ø 49 x 42	Ø 19½" x 16¾"
XL 80 x 80 x 25	31½" x 31½" x 10"
XXL Ø 120 x 35	Ø 47¼" x 14"

Ciotola ottone lucido	Bright brass plate
S Ø 19 x 50	Ø 7½" x 19¾"
M Ø 26 x 39	Ø 10¼" x 15½"
L Ø 49 x 47	Ø 19½" x 18¾"

[For technical drawing / p. 352](#)

[Pricelist 2023 / p. 160](#)  
[Homescapes, intimate portraits / pp. 52, 55, 88, 92](#)  
[Homescapes, gentle attitude / pp. 104](#)

## PIANO/TOP



Marmo lucido naturale  
Calacatta Vagli Oro  
Natural polished  
Calacatta Vagli Oro marble

## CIOTOLA/PLATE



Ottone lucido  
Bright brass

## STRUTTURA/STRUCTURE



Ottone brunito a mano  
Hand burnished brass

# Zen Black Low

Massimo Castagna / 2020

Tavolino con piano in frassino spazzolato tinto nero a poro aperto, in cristallo temperato decorato a mano nella finitura Craquelé, in marmo lucido naturale Verde Alpi e Bianco Carrara Gioia, in marmo Nero Marquinia levigato opaco o in marmo Fior di Pesco spazzolato. Base in alluminio spazzolato a mano e anodizzato nero con dettagli in metallo laccato nero.

Coffee table with black brushed open pore stained ash top. Also available with tempered hand decorated Craquelé glass top or in natural polished Verde Alpi or Bianco Carrara Gioia, in honed mat Nero Marquinia or brushed Fior di Pesco marble. Black hand brushed anodised aluminium base with black lacquered metal details.

## NOTE TECNICHE SUI MATERIALI

**CRISTALLO** | Le finiture esclusive risultato della lavorazione manuale realizzata sul cristallo possono presentare striature e differenze cromatiche. Queste caratteristiche non devono essere considerate difetti ma elementi distintivi del processo artigianale che esaltano la bellezza e la peculiarità del pezzo unico.

**MARMO** | Il marmo è un materiale naturale di origine sedimentaria che può presentare particolarità come venature, lievi irregolarità superficiali, colorazioni differenti e cristallizzazioni. Queste peculiarità sono da attribuirsi alla naturalezza del materiale e non sono da considerarsi difetti ma caratteristiche tipiche del marmo. Ogni prodotto risulterà unico, esclusivo e non replicabile. I nostri marmi vengono trattati con un prodotto idrorepellente che permette una maggiore protezione della superficie stessa, aumentando l'impermeabilità. Questo trattamento non esclude la vulnerabilità del marmo alle sostanze acide.

## TECHNICAL INFORMATION ON THE MATERIALS

**GLASS** | Exclusive finishes, resulting from the craftsmanship on the glass, may show streaks and chromatic differences. These characteristics should not be considered imperfections but distinctive evidence of the hand-made process that enhance the beauty and peculiarity of the unique piece.

**MARBLE** | The marble is a natural material of sedimentary origin that can present particularities such as veins, slight surface irregularities, different colors and crystallizations. These peculiarities are to be attributed to the naturalness of the material and are not to be considered defects but typical characteristics of marble. Each product will be unique, exclusive and non-replicable. Our marbles are treated with water-repellent products which affords greater protection to the surface of the marble, improving its impermeability. This treatment doesn't exclude the vulnerability of the marble to acid substances.



**Cm**  
Ø 100 x 47  
Ø 120 x 47

**Inches**  
Ø 39½" x 18¾"  
Ø 47½" x 18¾"

For technical drawing / p. 353

Pricelist 2023 / p. 161

## PIANO/TOP

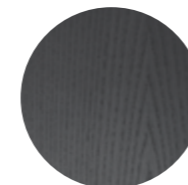

**Frassino spazzolato tinto nero a poro aperto**  
Black open pore brushed stained ash



**Cristallo Craquelé**  
Craquelé glass

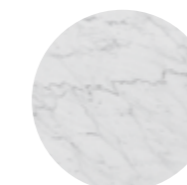

**Marmo lucido naturale Bianco Carrara Gioia**  
Natural polished Bianco Carrara Gioia marble



**Marmo spazzolato Fior di Pesco**  
Brushed Fior di Pesco marble



**Marmo levigato opaco Nero Marquinia**  
Honed mat Nero Marquinia marble



**Marmo lucido naturale Verde Alpi**  
Natural polished Verde Alpi marble

## BASE/BASE

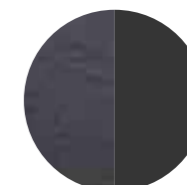

**Alluminio spazzolato e anodizzato nero/ Metallo laccato nero**  
Hand brushed anodised aluminium / Black metal details

## ▲ ZEN BLACK LOW

Piano in marmo lucido naturale Verde Alpi / Base in alluminio spazzolato anodizzato nero e metallo laccato nero  
Natural polished Verde Alpi marble top / Black hand brushed anodised aluminium base with black metal details



▲ ZEN LOW  
Piano in frassino spazzolato tinto nero a poro aperto / Piano in cristallo decorato a mano Craquelé  
Black open pore brushed stained ash top / Hand-decorated Craquelé glass top

# Zen Low

Massimo Castagna / 2018

Tavolino con piano in frassino spazzolato tinto nero a poro aperto. Disponibile anche con piano in cristallo temperato decorato a mano nella finitura Craquelé. Base in alluminio spazzolato a mano e anodizzato nero con dettagli ottonati lucidi.

Coffee table with black open pore brushed stained ash top. Also available with tempered hand decorated Craquelé glass top. Black hand brushed anodised aluminium base with bright brass plated details.

## NOTE TECNICHE SUI MATERIALI

**CRISTALLO** | Le finiture esclusive risultato della lavorazione manuale realizzata sul cristallo possono presentare striature e differenze cromatiche. Queste caratteristiche non devono essere considerate difetti ma elementi distintivi del processo artigianale che esaltano la bellezza e la peculiarità del pezzo unico.

## TECHNICAL INFORMATION ON THE MATERIALS

**GLASS** | Exclusive finishes, resulting from the craftsmanship on the glass, may show streaks and chromatic differences. These characteristics should not be considered imperfections but distinctive evidence of the hand-made process that enhance the beauty and peculiarity of the unique piece.



	Cm	Inches
A	Ø 100 x 47	Ø 39½" x 18¾"
B-C-D	90 x 90 x 47	35½" x 35½" x 18¾"
E	105 x 50 x 47	41½" x 19¾" x 18¾"

[For technical drawing / p. 353](#)

[Pricelist 2023 / p. 162](#)  
[Homescapes, sense of materials / p. 92](#)

## PIANO/TOP

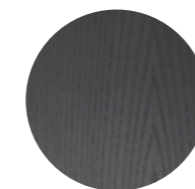

Frassino spazzolato tinto nero a poro aperto  
Black open pore brushed stained ash



Cristallo Craquelé  
Craquelé glass

## BASE/BASE



Alluminio spazzolato nero / Metallo ottonato lucido  
Black brushed aluminium / Bright brass metal



# 06

**Tavolini / Coffee Tables**  
**TECHNICAL MODULE**



**1968** | Studio G&R, 2019

Product information / p. 256

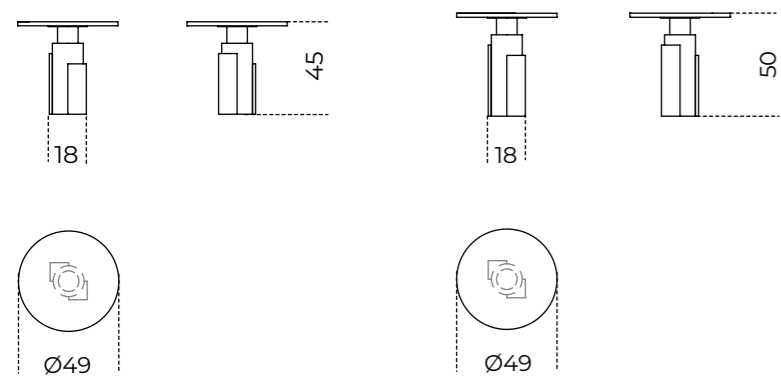

**Connection** | Massimo Castagna, 2013

Product information / p. 264

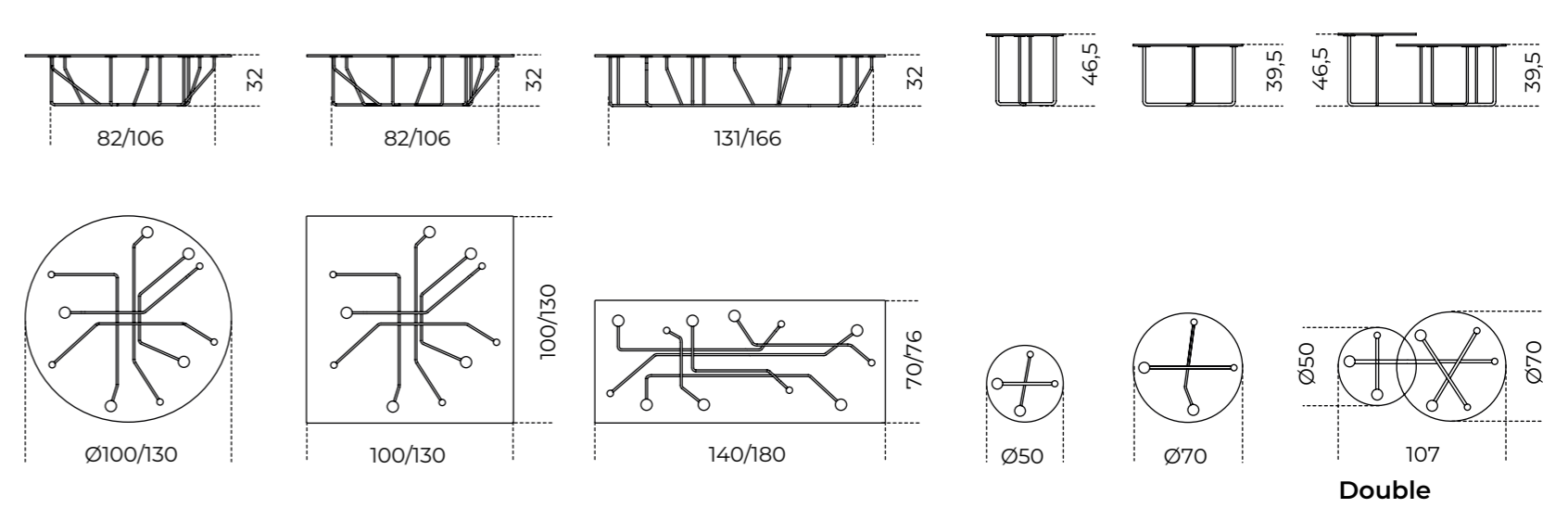

**Chantal** | Studio G&R, 2013

Product information / p. 258

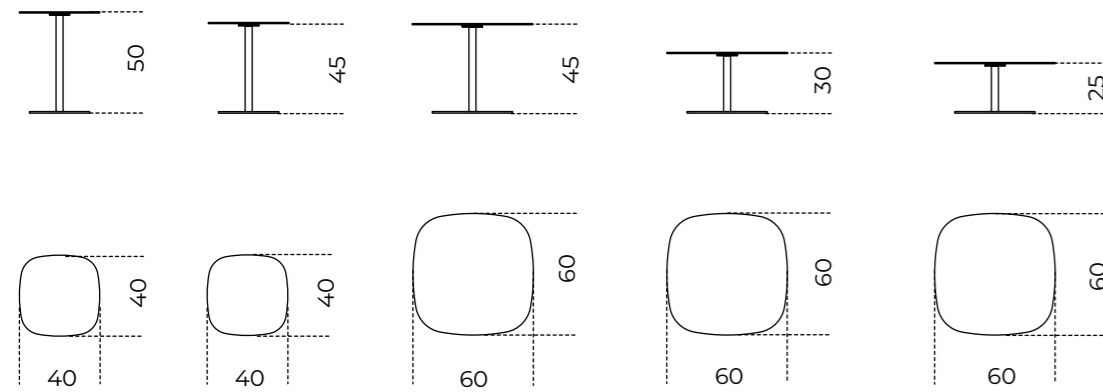

**Cookies** | Pietro Russo, 2017

Product information / p. 266

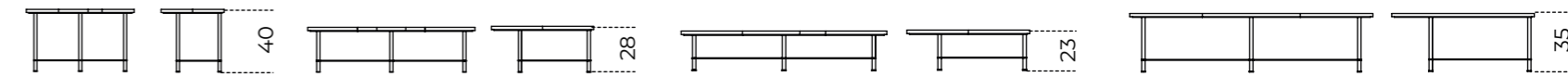

**Marmo Calacatta Vagli Oro**  
Calacatta Vagli Oro marble

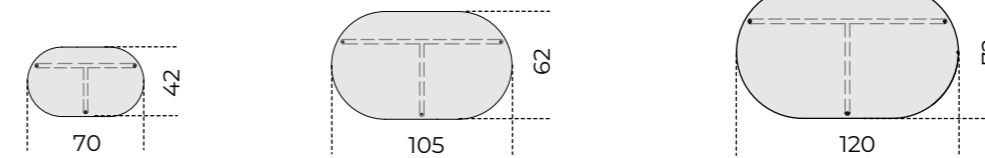

**Marmo Bianco Statuario/Nero Marquina**  
Bianco Statuario/Nero Marquina marble

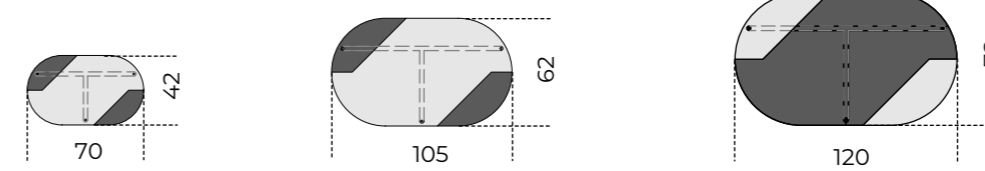

**Clemo** | Massimo Castagna, 2021

Product information / p. 260

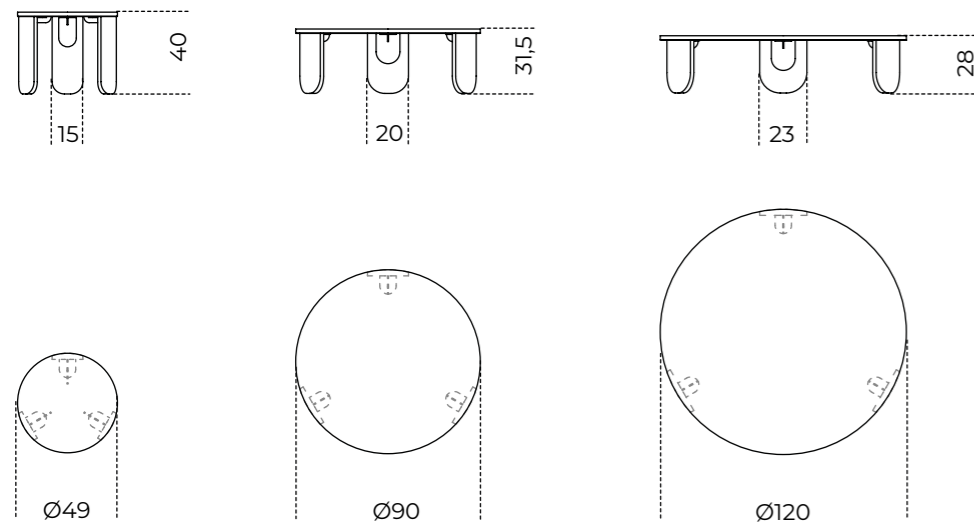

**Legno intarsiato "Tweed"/Acero Frisé**  
Inlaid wooden "Tweed"/Maple Frisé

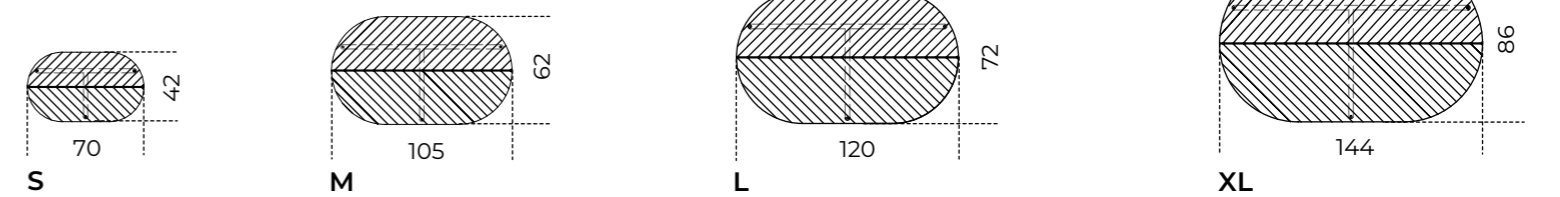

**Cookies Circle** | Pietro Russo, 2019

Product information / p. 268

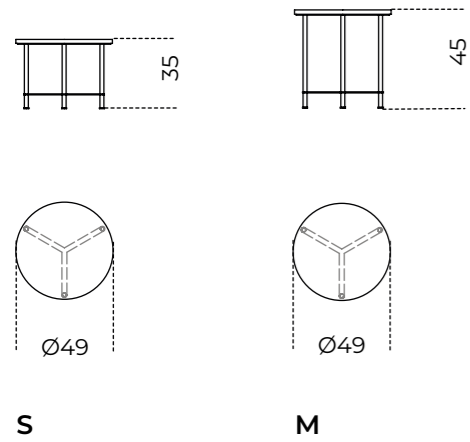

**Fante** | Studio G&R, 2015

Product information / p. 274

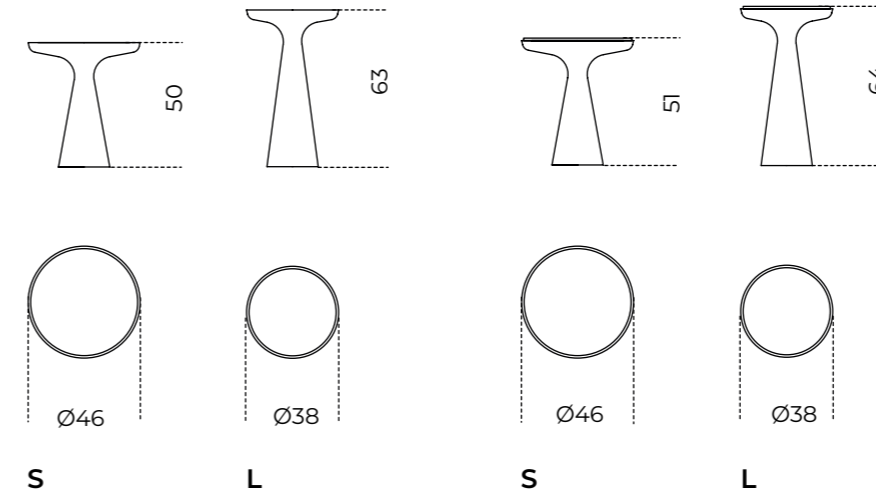

**Piano in marmo**  
Marble top

**Dama** | Studio G&R, 2015

Product information / p. 270

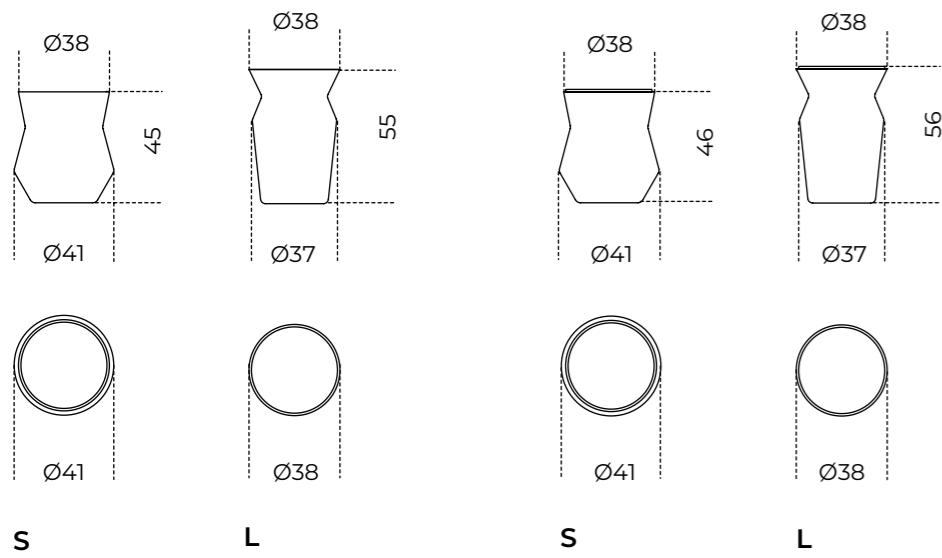

**Piano in marmo**  
Marble top

**Faraday** | Märten Claesson, Ola Rune, Eero Koivisto, 2007

Product information / p. 276

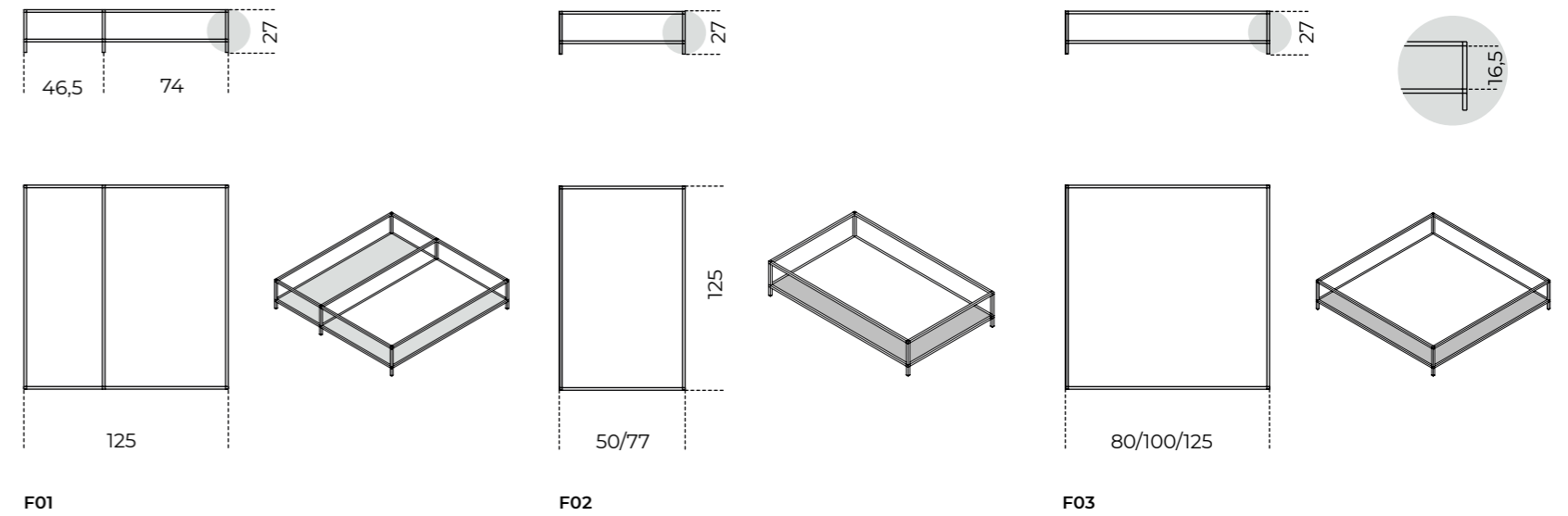

**Drummers** | Massimo Castagna, 2023

Product information / p. 272

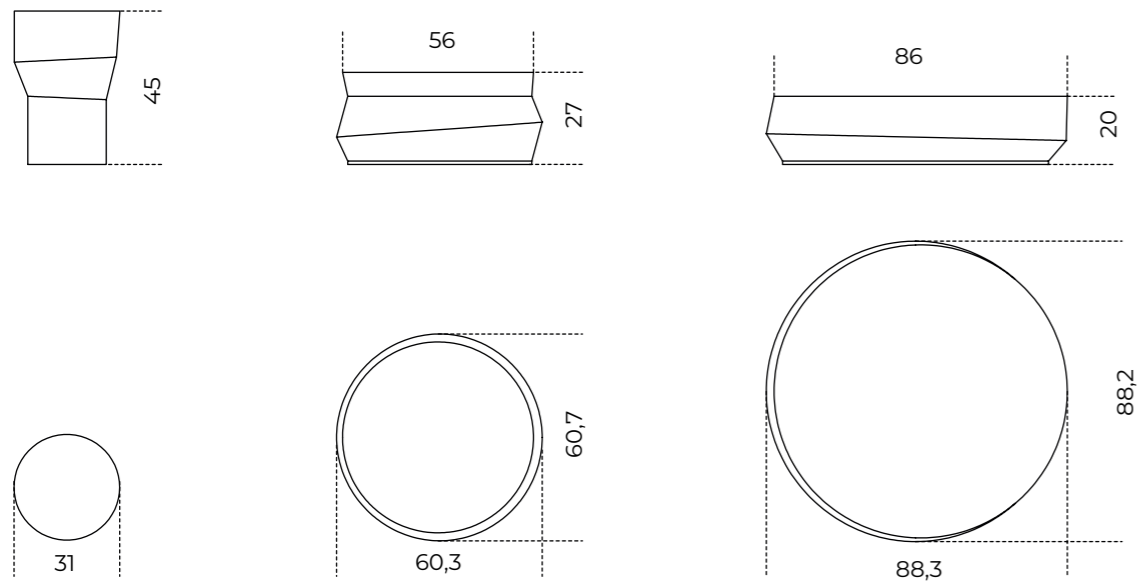

**George1** | Pierangelo Gallotti, 1975

Product information / p. 278

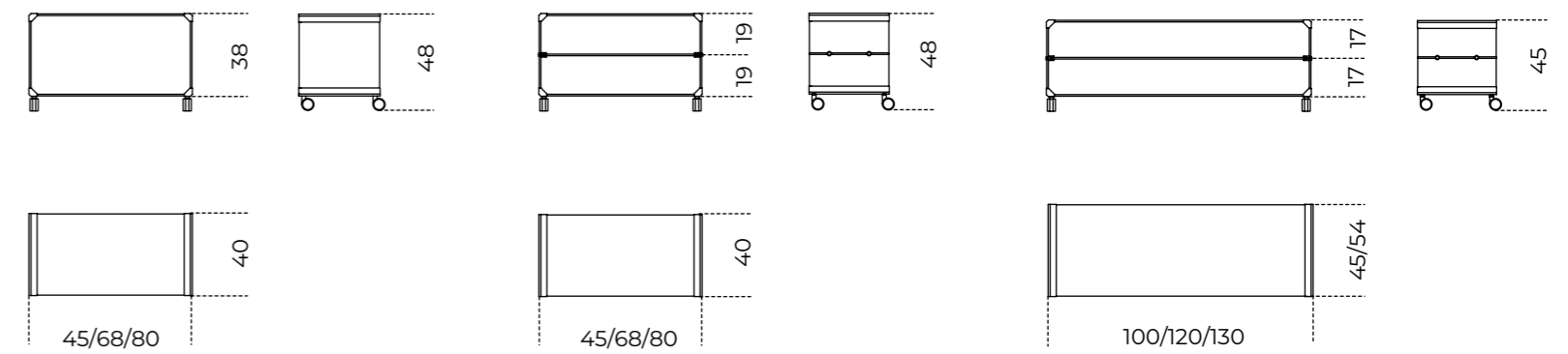

**George 2** | Pierangelo Gallotti, 1975

Product information / p. 280

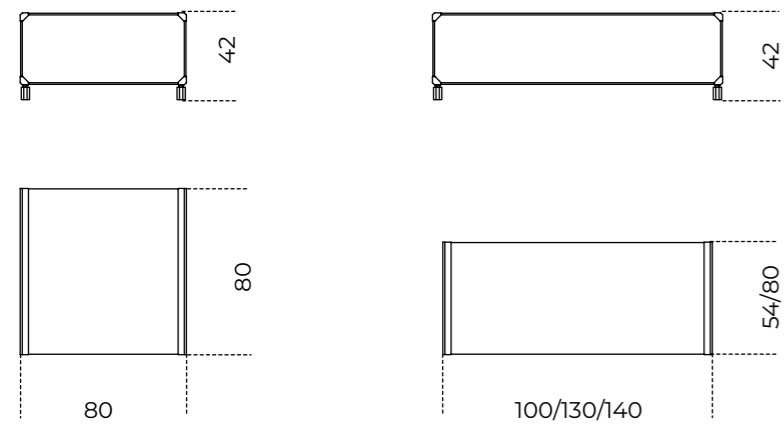

**Haumea** | Massimo Castagna, 2015

Product information / p. 286

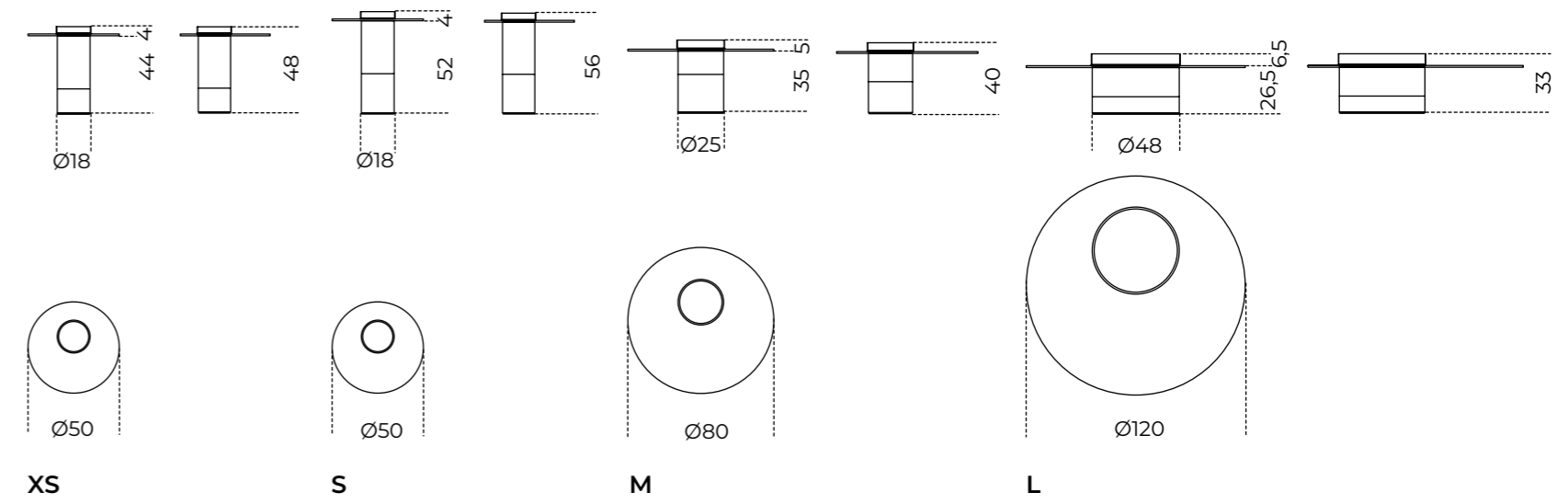

**Golden Moon** | Massimo Castagna, 2015

Product information / p. 282

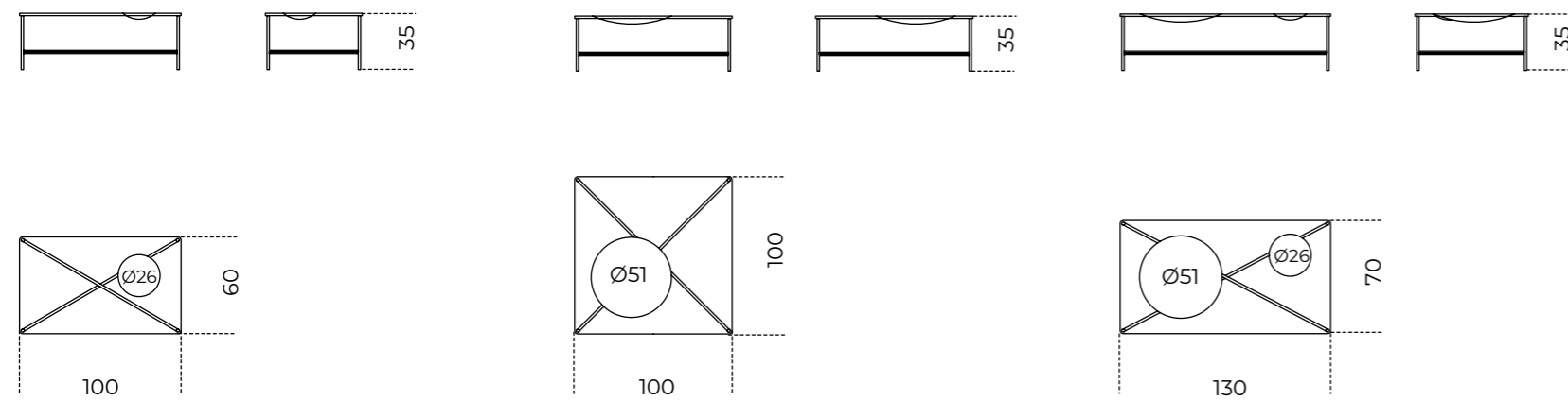

**Hide&Seek Mini** | Pietro Russo, 2024

Product information / p. 290

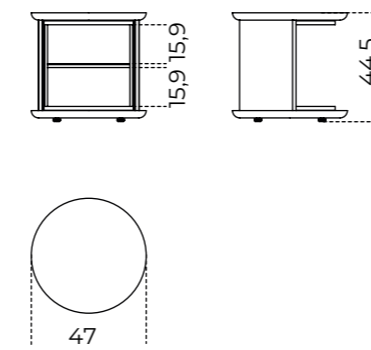

**Gong** | Studio G&R, 2017

Product information / p. 284

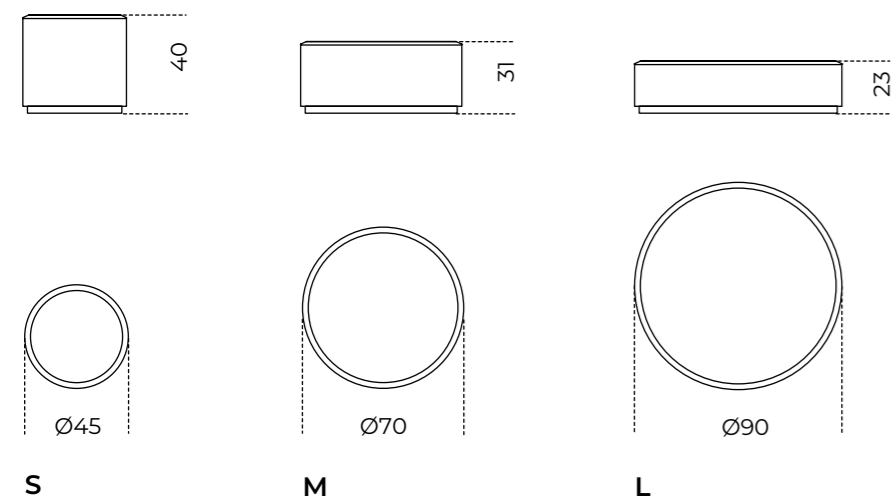

**Monete** | Massimo Castagna, 2021

Product information / p. 292

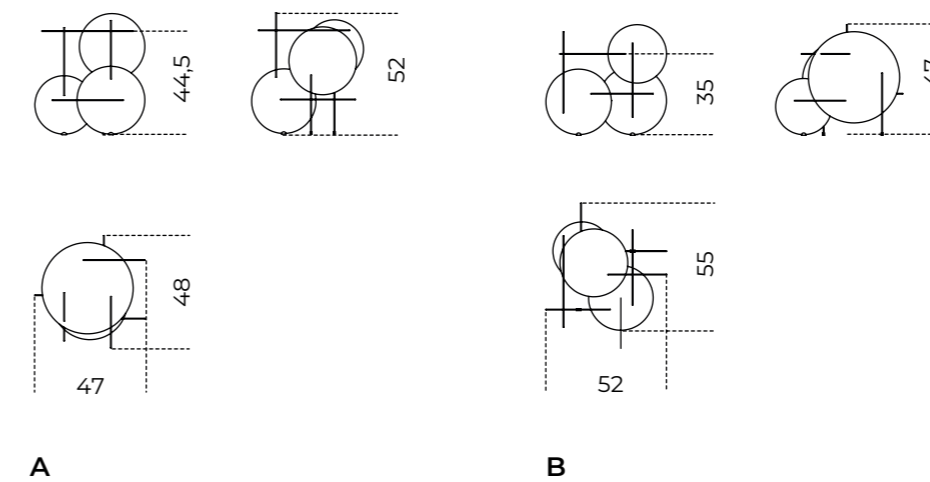

**Nori** | Studio G&R, 2018

Product information / p. 296

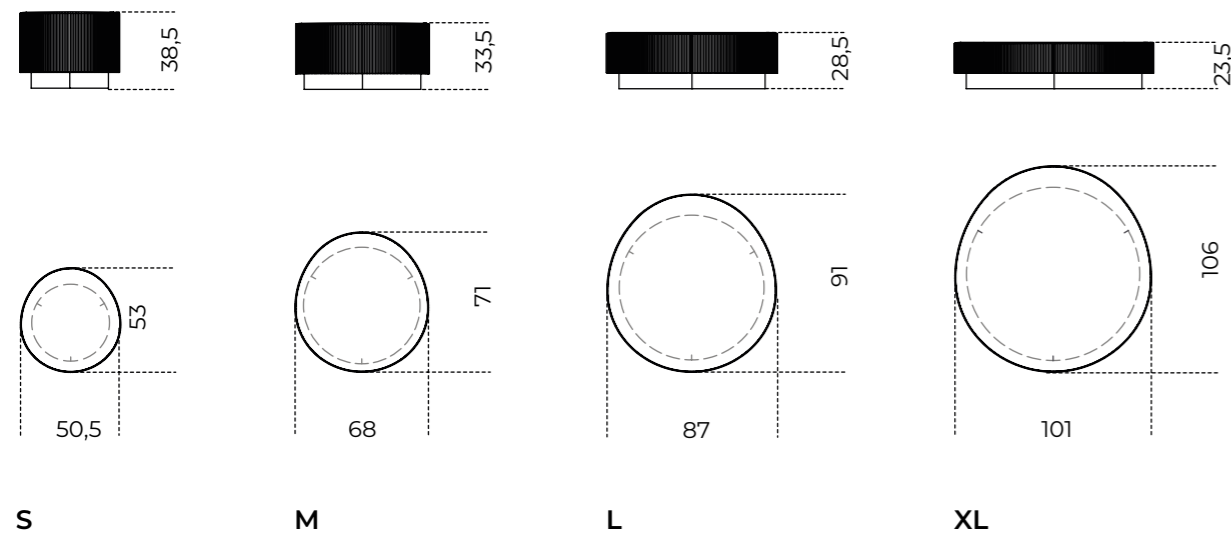

**Prism Low** | David/Nicolas, 2019

Product information / p. 302

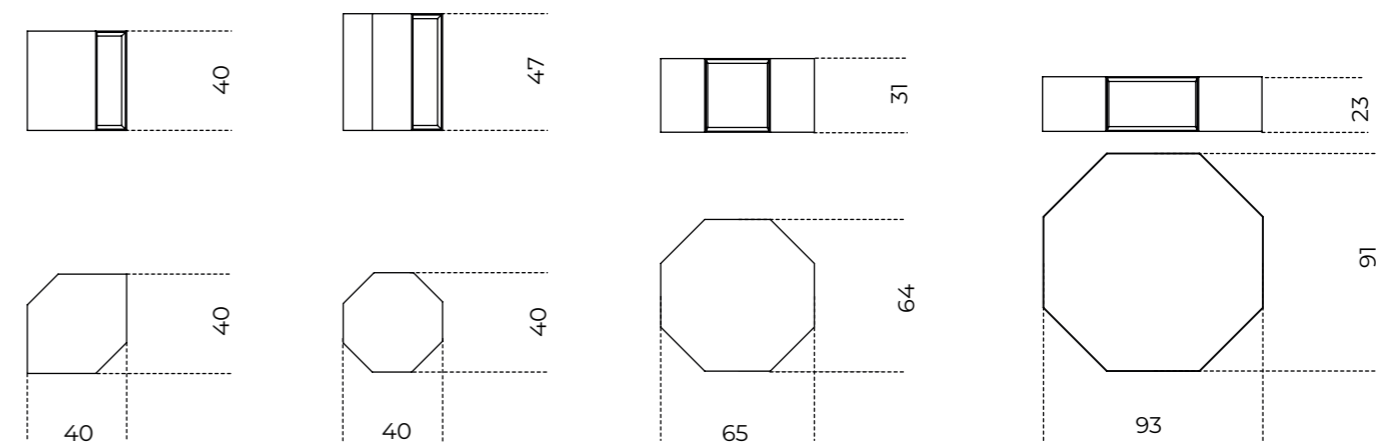

**Nox** | Ricardo Bello Dias, 2009

Product information / p. 398

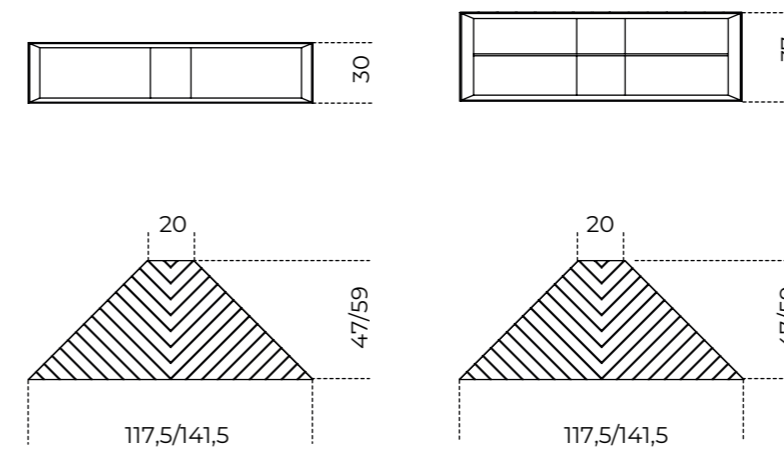
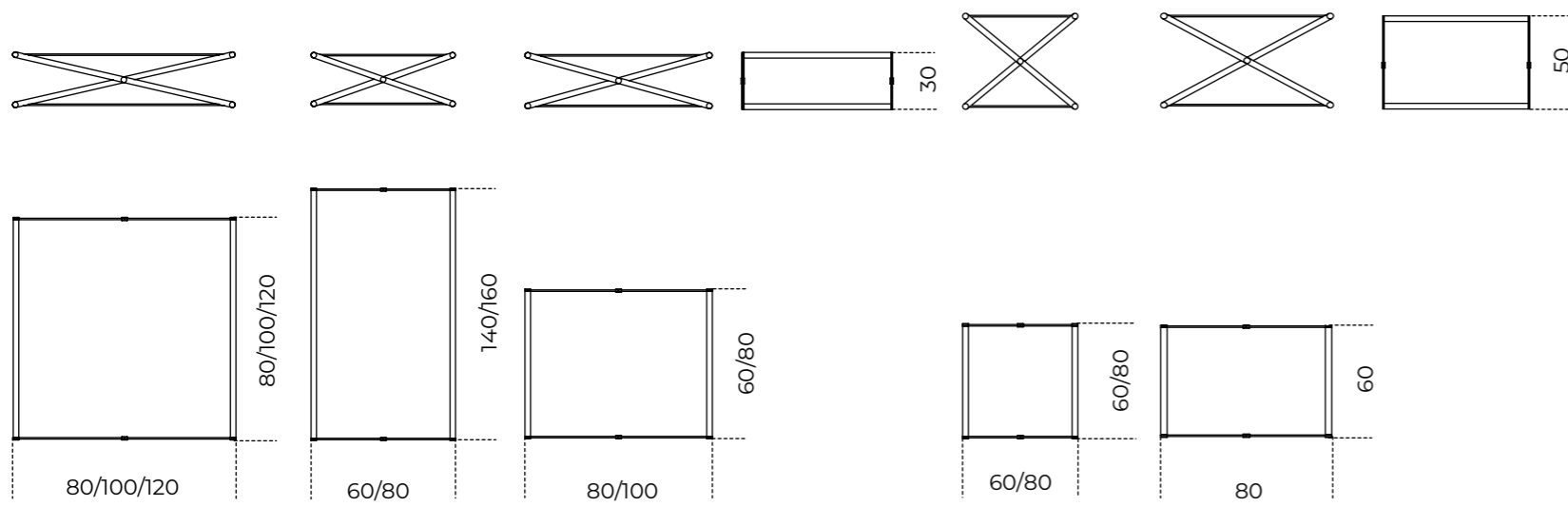

**Oto Mini** | Oscar e Gabriele Buratti, 2015

Product information / p. 300

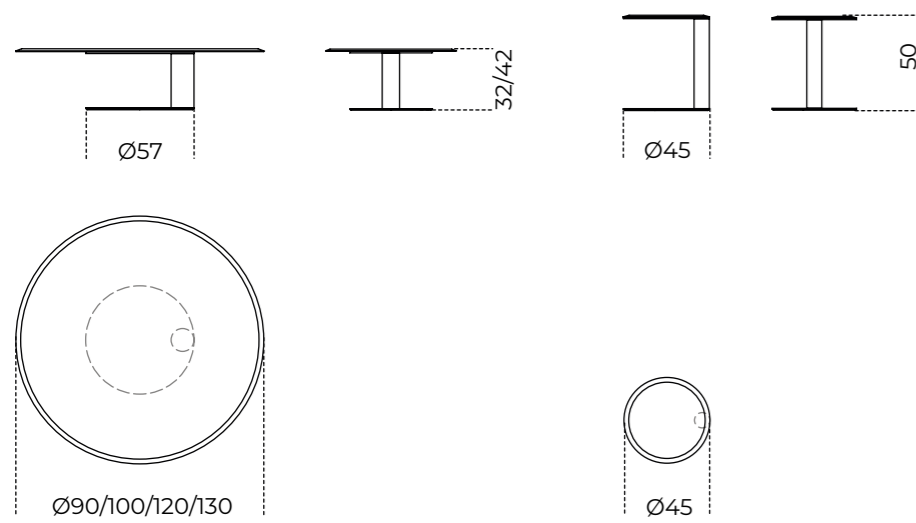

**Raj1** | Ricardo Bello Dias, 2006

Product information / p. 304

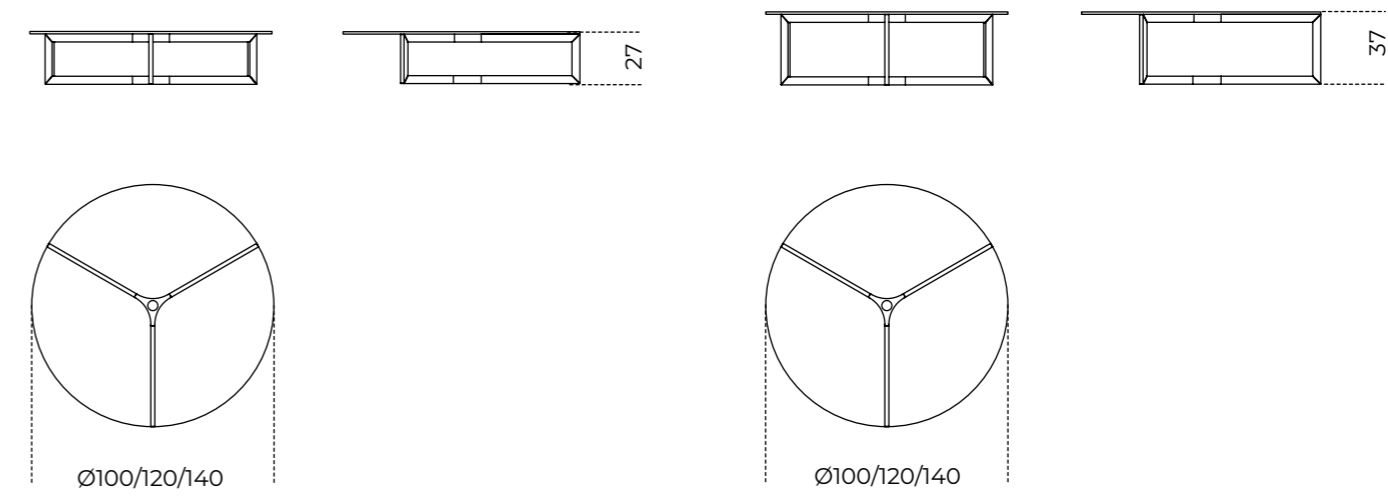

**Raj 2** | Ricardo Bello Dias, 2006

Product information / p. 306

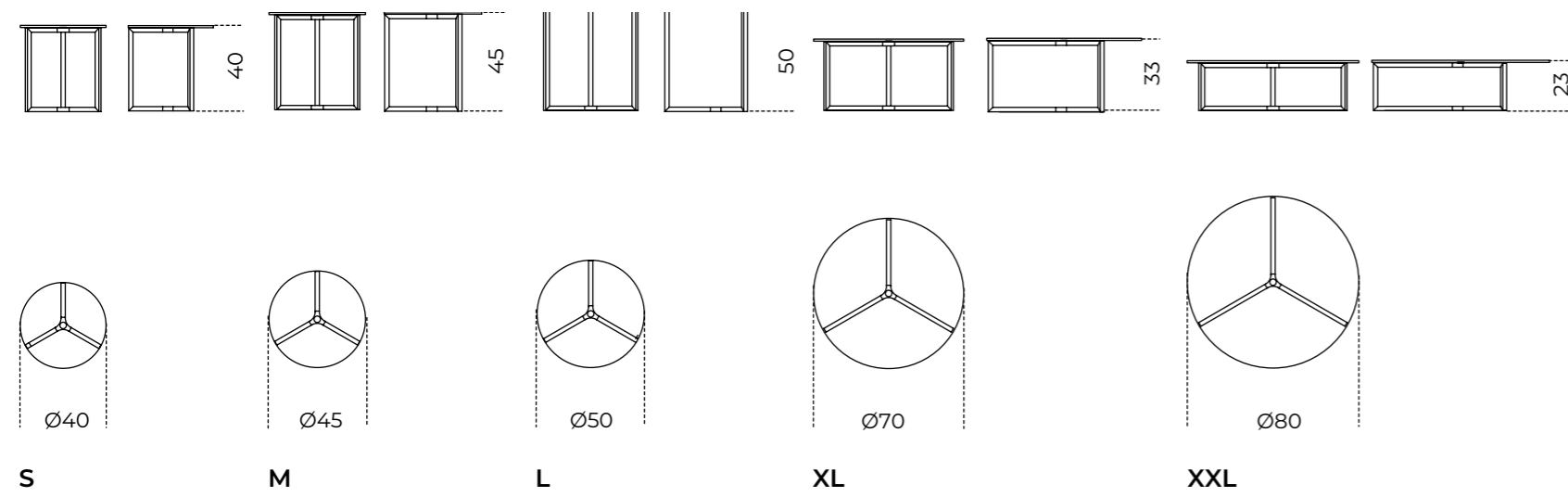

**Re-verre** | Federica Biasi, 2023

Product information / p. 312

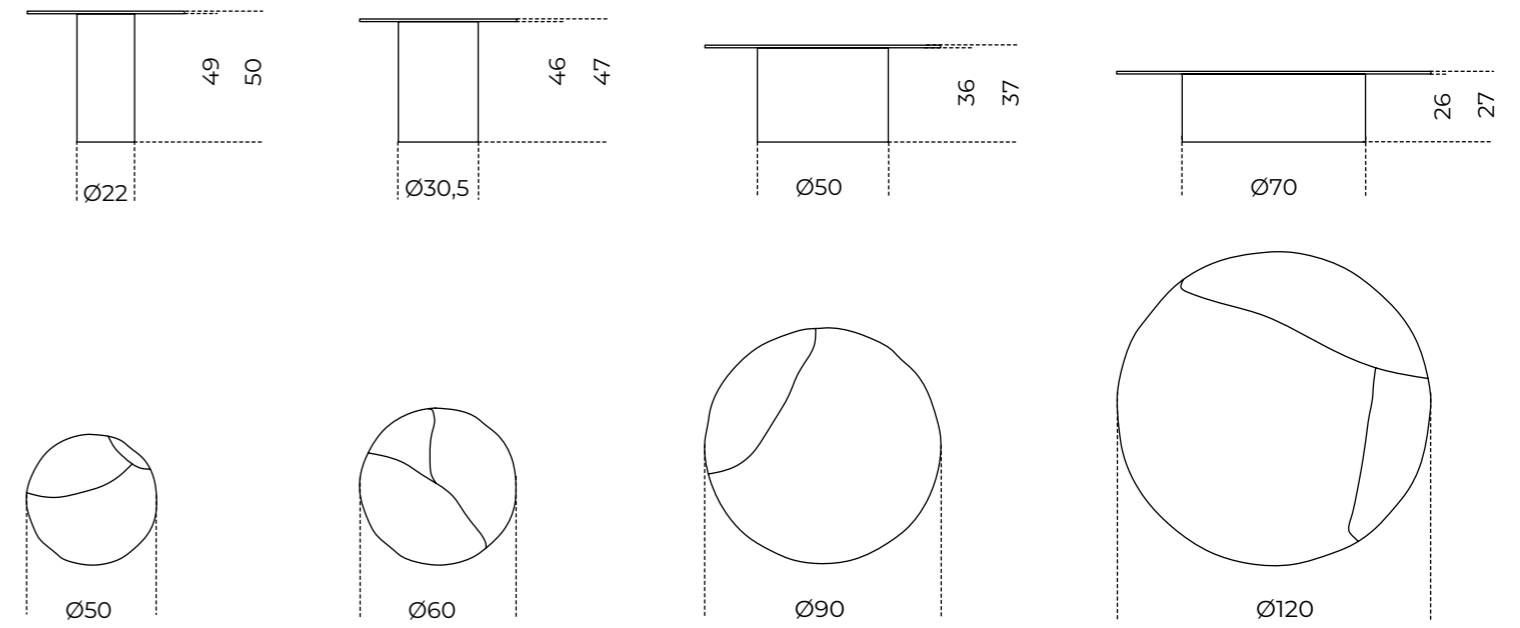

**Raj 3** | Ricardo Bello Dias, 2011

Product information / p. 308

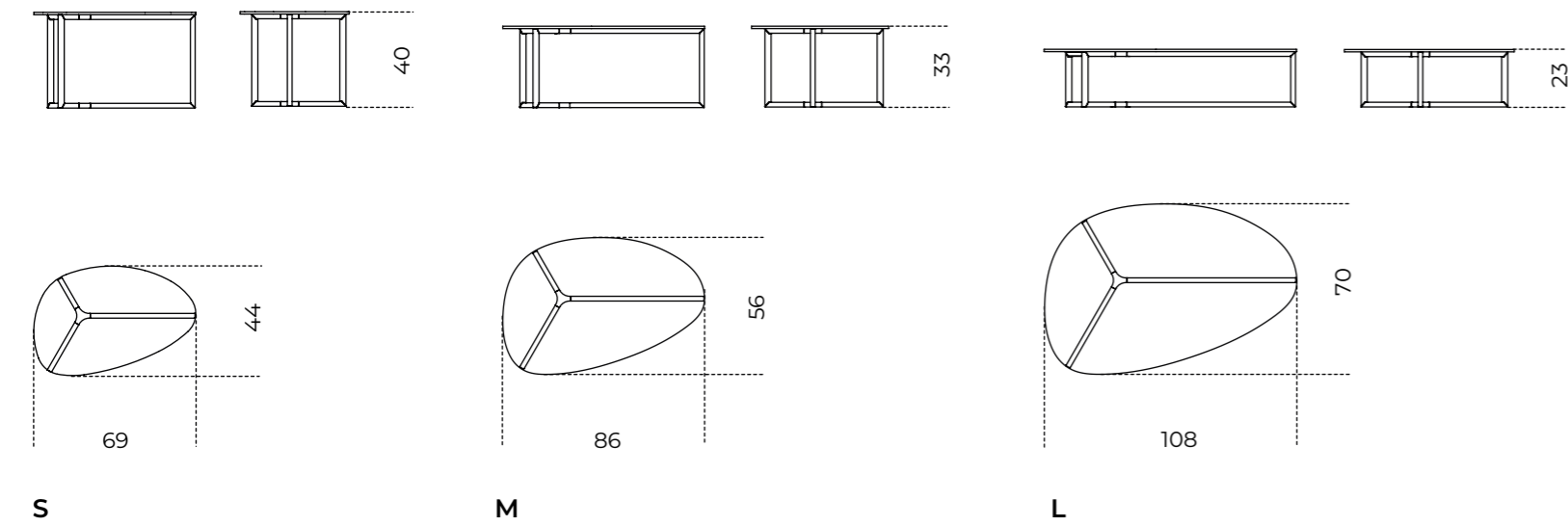

**Selce** | Studiopepe, 2023

Product information / p. 316

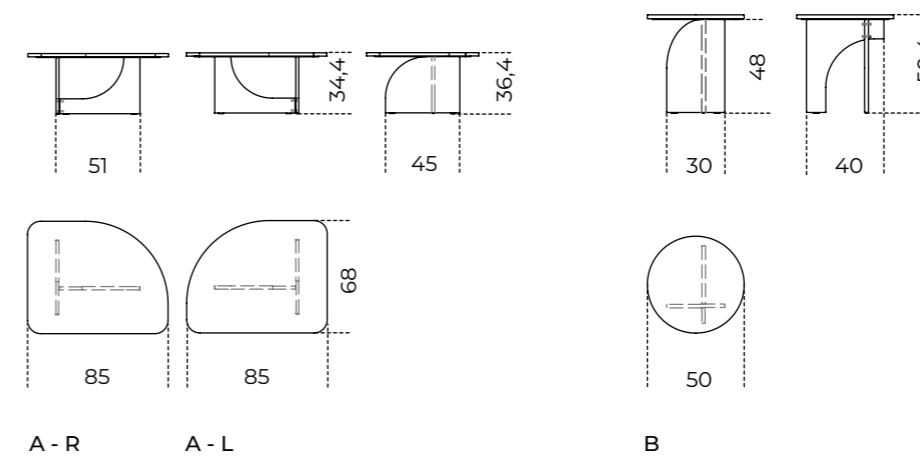

**Raj 6** | Ricardo Bello Dias, 2013

Product information / p. 310

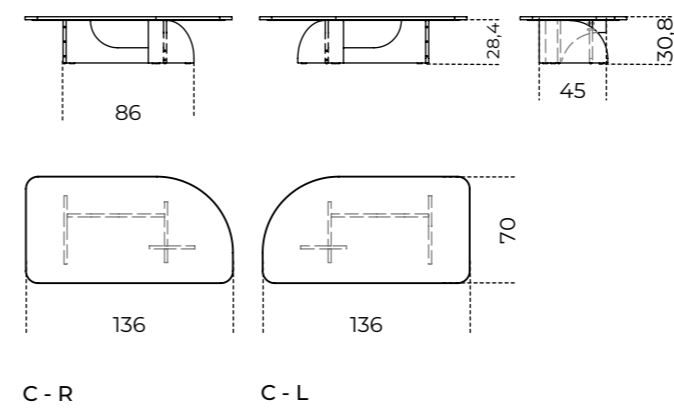
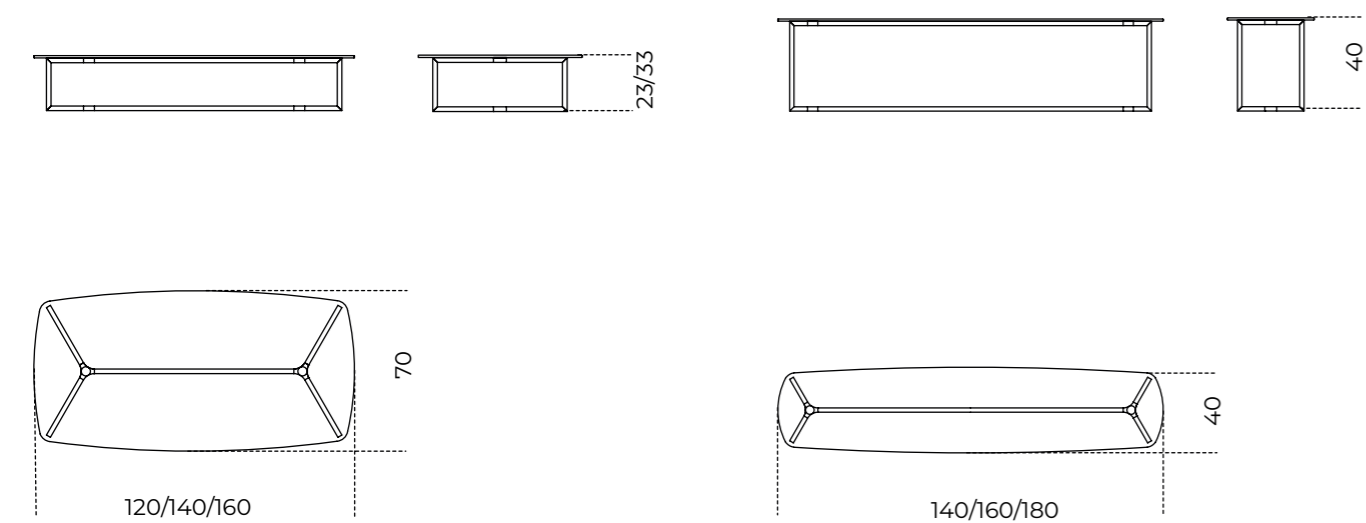

**Piano in legno con scasso**  
Burglary wooden top

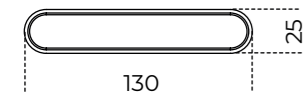

A

**Piano in cristallo**  
Glass top



**Piano in marmo**  
Marble top

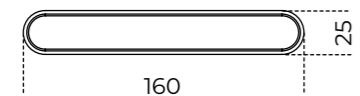

B

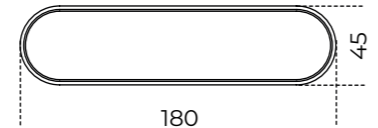

C

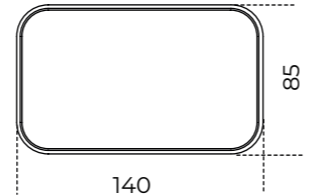
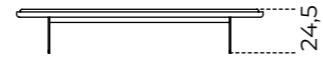

D

**Piano in cristallo**  
Glass top

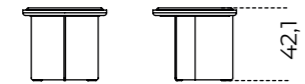

**Piano in marmo**  
Marble top

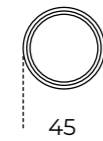
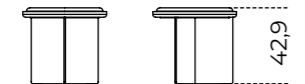

E

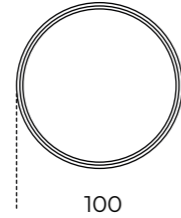
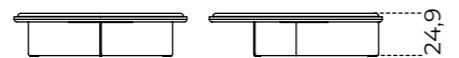
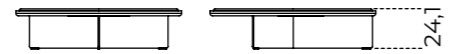

F

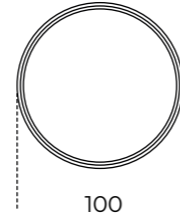
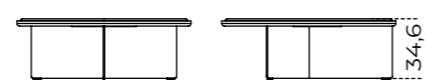

G

**Composizioni**  
Compositions

**Composizione 1 / Composition 1**

Composta da  
Composed by

- n.1 D 140 x 85 x 24,5h "Rosso Marte"
- n.1 C 180 x 45 x 35h Calacatta Vagli Oro
- n.1 A 130 x 25 x 43h legno/wood

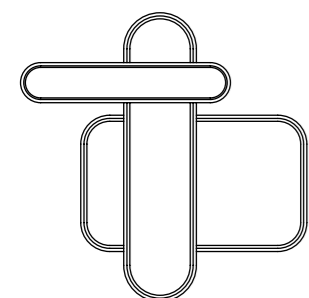

**Composizione 2 / Composition 2**

Composta da  
Composed by

- n.1 B 160 x 25 x 35h "Rosso Marte"
- n.1 C 180 x 45 x 35h Calacatta Vagli Oro
- n.1 A 130 x 25 x 43h legno/wood

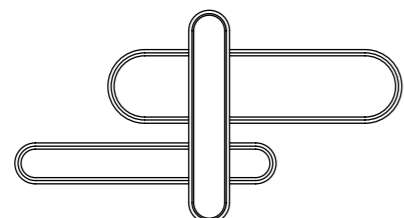

**Composizione 3 / Composition 3**

Composta da  
Composed by

- n.1 D 140 x 85 x 25h "Rosso Marte"
- n.1 C 180 x 45 x 35h Calacatta Vagli Oro
- n.1 B 160 x 25x34,5h "Rosso Marte"

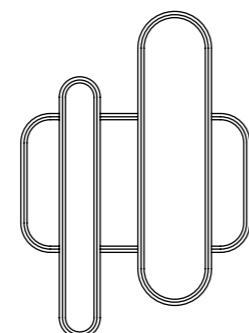

**Composizione 4 / Composition 4**

Composta da  
Composed by

- n.1 A 130 x 25 x 43h legno/wood
- n.1 D 140 x 85 x 25h "Rosso Marte"
- n.1 C 180 x 45x 35h Calacatta Vagli Oro
- n.1 B 160 x 25x34,5h "Rosso Marte"

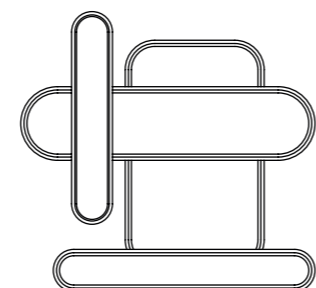

**Sir T 32/Sir T32 C** | Pierangelo Gallotti, 1971

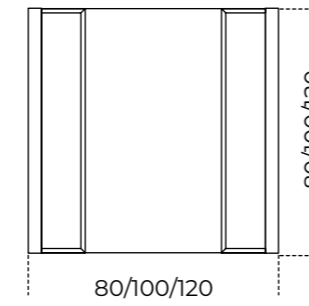

Sir T 32

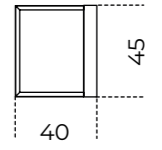
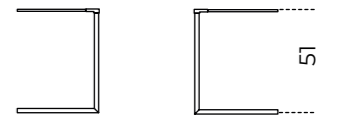
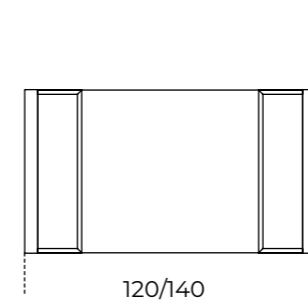

Sir T32C

**T33** | Pierangelo Gallotti, 1982

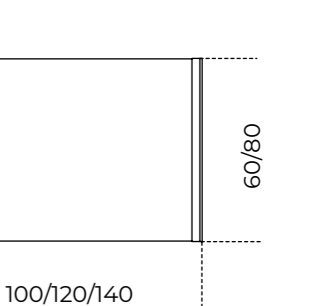
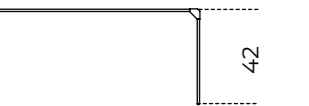
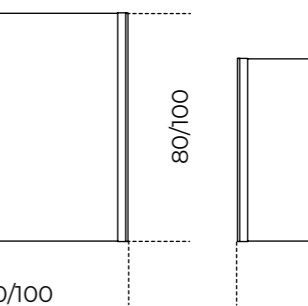
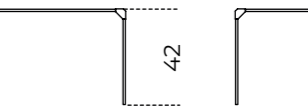
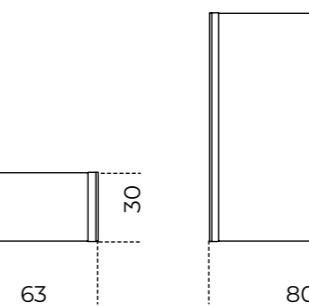
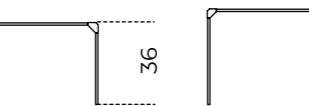
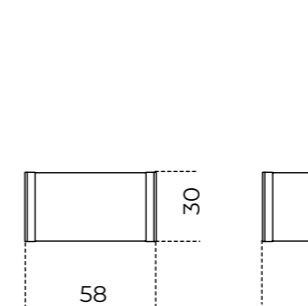
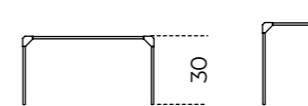
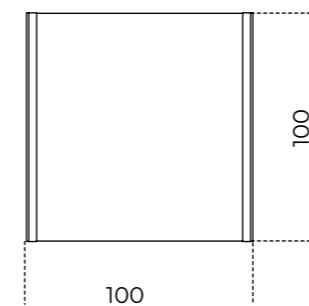

**T35 R** | Pierangelo Gallotti, 1975

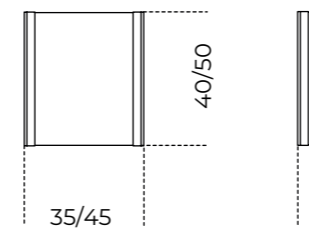
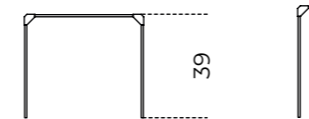

35/45

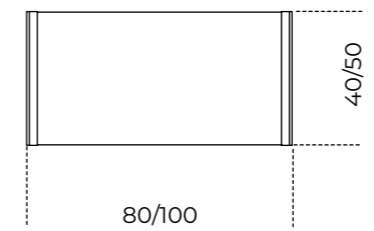

80/100

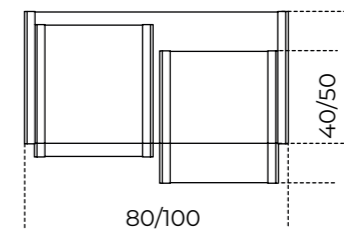
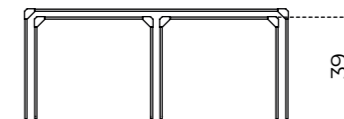

Set

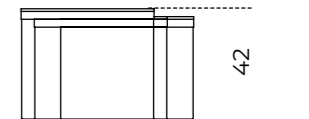

40/50



**T35 Trio** | Pierangelo Gallotti, 1975

Product information / p. 326

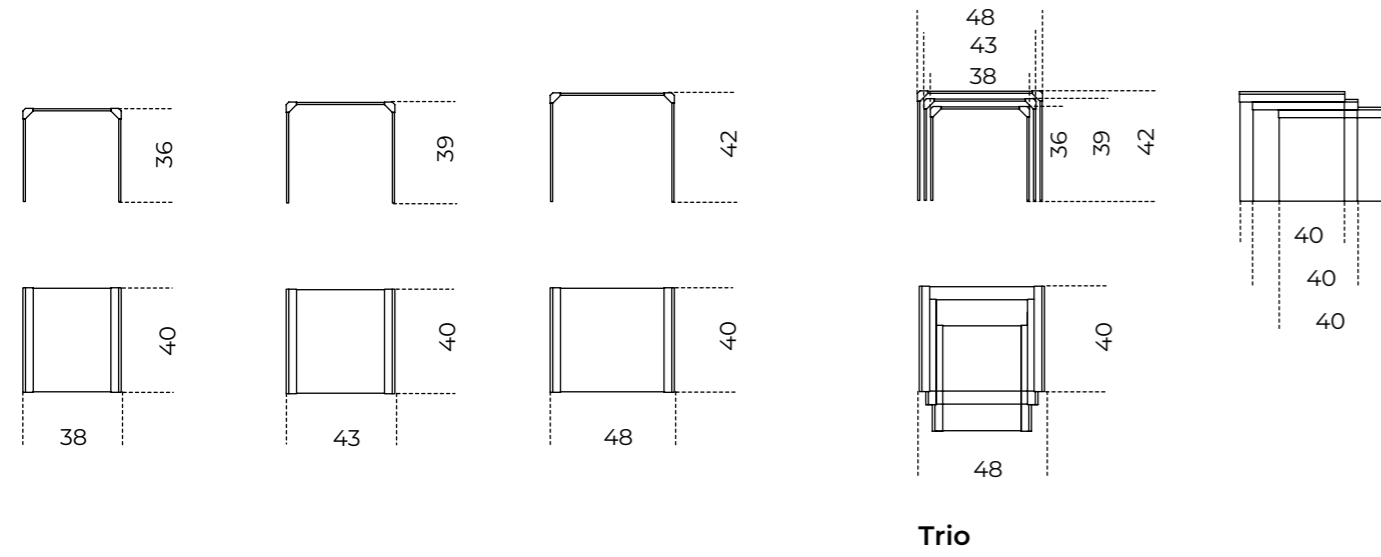

**Zen Black Low** | Massimo Castagna, 2020

Product information / p. 332

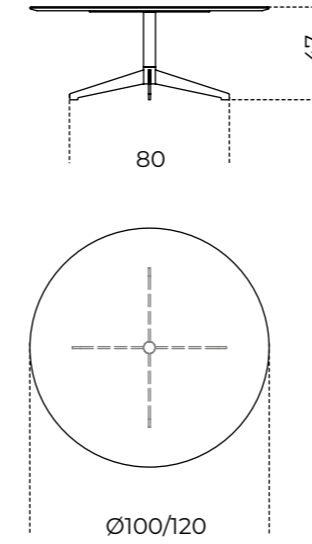

**Tetris** | Massimo Castagna, 2014

Product information / p. 328

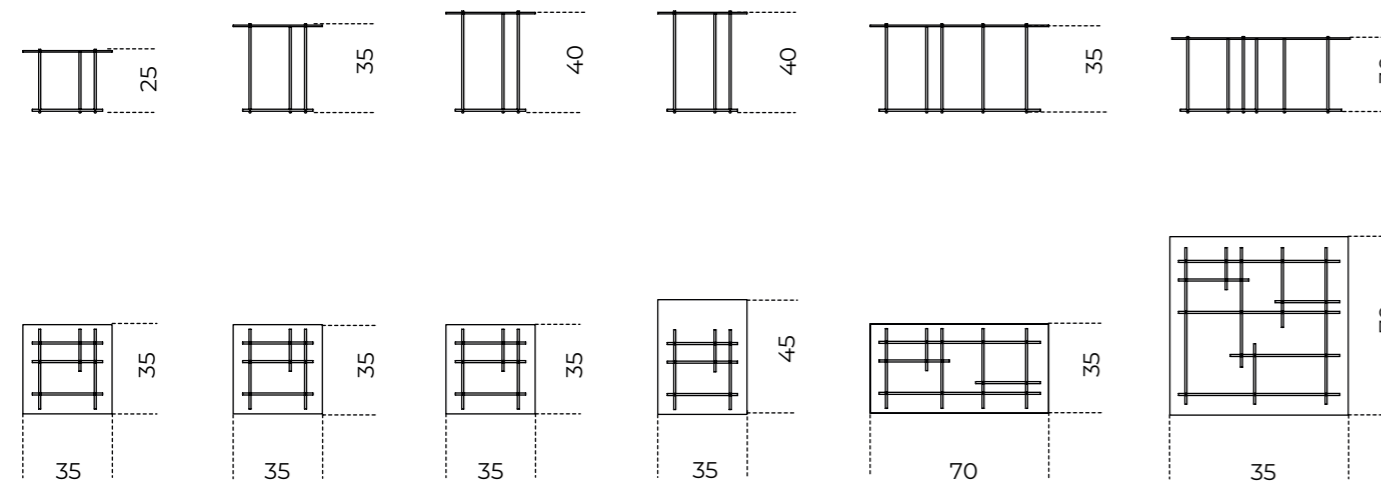

**Zen Low** | Massimo Castagna, 2018

Product information / p. 334

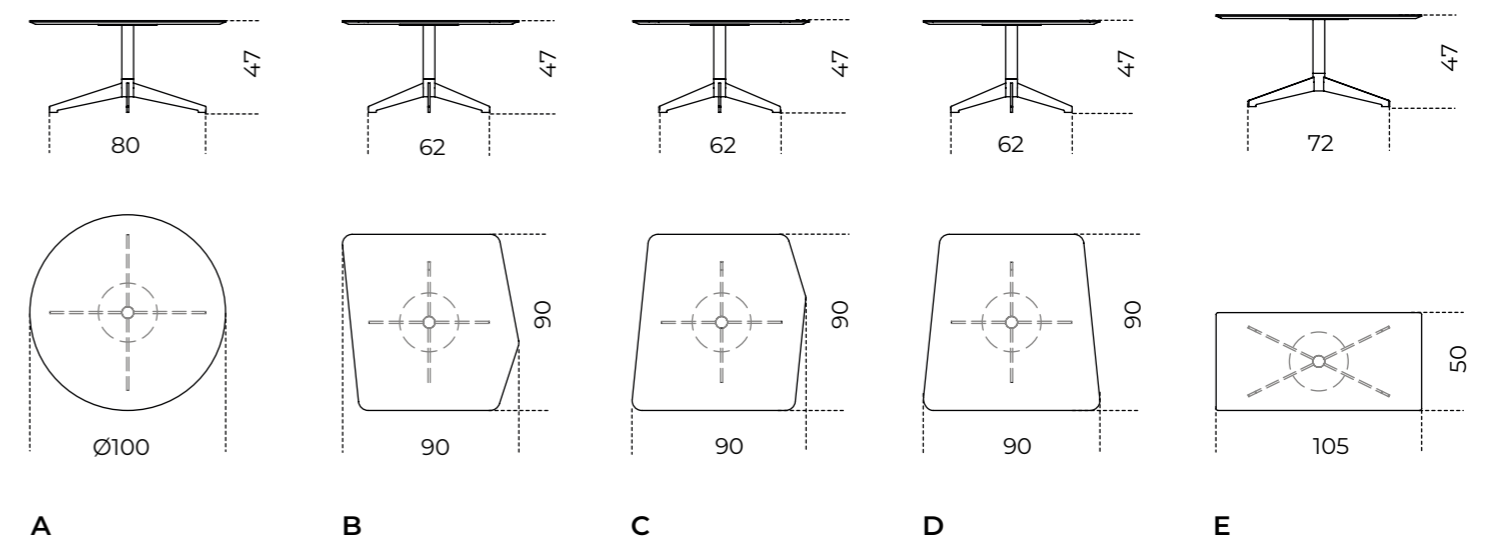

**Twelve** | Massimo Castagna, 2016

Product information / p. 330

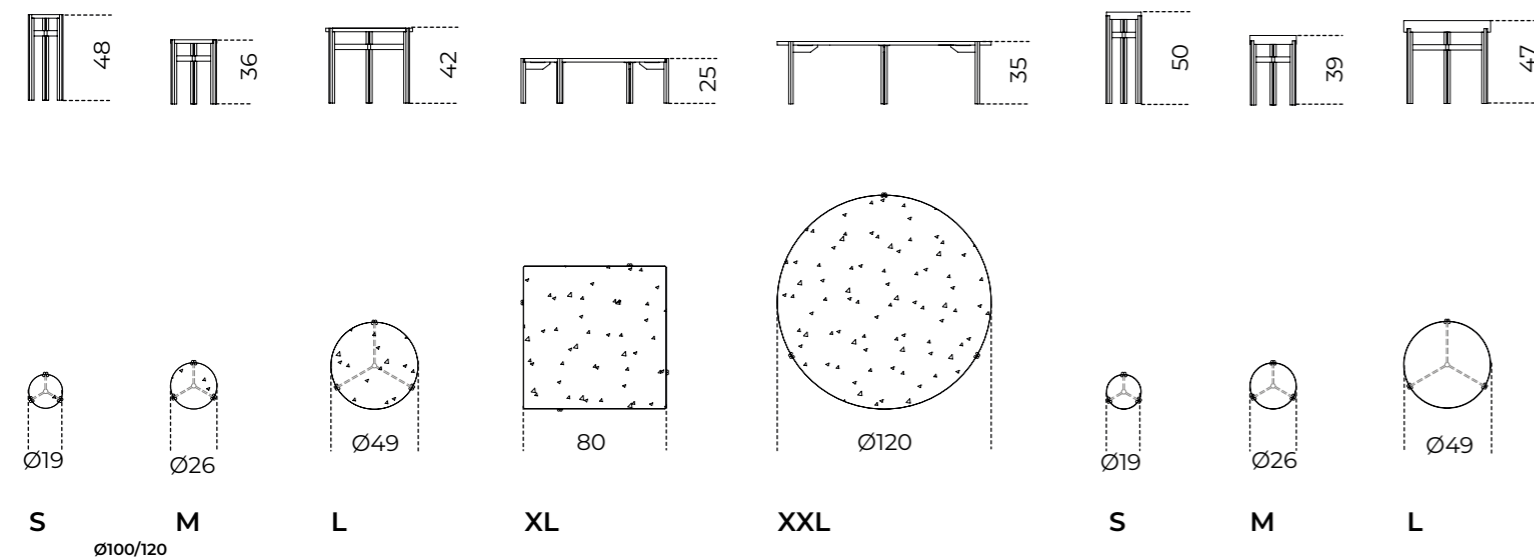

## **07** Console / Consoles

356 [Athus Console](#)  
358 [Dolm Console](#)  
360 [Hanami](#)  
362 [Sensei Console](#)  
364 [Tama Console](#)

366 [Informazioni tecniche/  
Technical informations](#)

# Athus Console

Oscar e Gabriele Buratti / 2013

Console in frassino tinto nero a poro aperto. Top in cristallo 6mm temperato retroverniciato nero brillante. Disponibile anche verniciato nella finitura esclusiva spazzolata "Cashmere" nei colori gold grey o anthracite. Cassetti ad estrazione totale con fondo in pelle scamosciata sand 006.

Console in black open pore stained ash. 6mm bright black painted tempered glass top. Also available painted with the exclusive brushed "Cashmere" finish in the gold grey or anthracite colours. Total pull-out drawers with suede sand 006 bottom.

## NOTE TECNICHE SUI MATERIALI

**CRISTALLO** | Le finiture esclusive, risultato della lavorazione manuale realizzata sul cristallo, possono presentare striature e differenze cromatiche. Queste caratteristiche non devono essere considerate difetti ma elementi distintivi del processo artigianale che esaltano la bellezza e la peculiarità del pezzo unico.

## TECHNICAL INFORMATION ON THE MATERIALS

**GLASS** | Exclusive finishes, resulting from the craftsmanship on the glass, may show streaks and chromatic differences. These characteristics should not be considered imperfections but distinctive evidence of the hand-made process that enhance the beauty and peculiarity of the unique piece.



▲ **ATHUS CONSOLE**  
Piano in cristallo retroverniciato nero brillante  
Bright black painted glass top



**Cm**  
150 x 46 x 80  
180 x 46 x 80

**Inches**  
59¼" x 18¼" x 31½"  
71" x 18¼" x 31½"

[For technical drawing / p. 368](#)

[Pricelist 2023 / p. 223](#)  
[Homescapes, sense of materials / p. 38](#)

## STRUTTURA/STRUCTURE

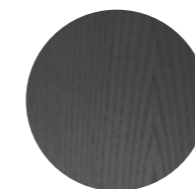

Frassino tinto  
nero a poro aperto  
Black open pore  
stained ash

## PIANO/TOP

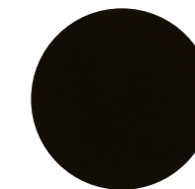

Cristallo retroverniciato  
nero brillante  
Bright black painted glass



Cristallo spazzolato  
"Cashmere" gold grey  
"Cashmere" gold grey  
brushed glass



Cristallo spazzolato  
"Cashmere" anthracite  
"Cashmere" anthracite  
brushed glass

## FONDO CASSETTI/ DRAWERS BOTTOM



Pelle scamosciata  
sand 006  
Suede sand 006

# Dolm Console

Oscar e Gabriele Buratti / 2013

Console con base in legno rivestito in cristallo 6mm temperato e con piano in appoggio in cristallo extralight 10mm temperato, retroverniciati nei colori del campionario, nella versione brillante o satinata. Disponibile versione verniciata nella finitura esclusiva spazzolata "Cashmere" gold grey e anthracite oppure bronzo patinato.

! L'azienda si riserva di scegliere il colore della trave in metallo coordinandola con la finitura del cristallo.

## NOTE TECNICHE SUI MATERIALI

**CRISTALLO** | Le finiture esclusive, risultato della lavorazione manuale realizzata sul cristallo, possono presentare striature e differenze cromatiche. Queste caratteristiche non devono essere considerate difetti ma elementi distintivi del processo artigianale che esaltano la bellezza e la peculiarità del pezzo unico.

Console with wooden base covered by 6mm tempered glass and 10mm extralight tempered glass top, painted as per samples in the bright or version. Also available version with glass painted with the exclusive "Cashmere" brushed finish in the colours gold grey and anthracite or patinated bronze.

! The company reserves the right to choose the colour of the metal beam, matching it with the glass finish.

## TECHNICAL INFORMATION ON THE MATERIALS

**GLASS** | Exclusive finishes, resulting from the craftsmanship on the glass, may show streaks and chromatic differences. These characteristics should not be considered imperfections but distinctive evidence of the hand-made process that enhance the beauty and peculiarity of the unique piece.



### Cm

120 x 44 x 74  
150 x 44 x 74  
180 x 44 x 74

### Inches

47 1/4" x 17 1/2" x 29 1/4"  
59 1/4" x 17 1/2" x 29 1/4"  
71" x 17 1/2" x 29 1/4"

[For technical drawing / p. 368](#)

[Pricelist 2023 / p. 224](#)  
[Homescapes, embracing beauty / p. 71](#)

▲ **DOLM CONSOLE**  
Piano e base in cristallo retroverniciato nero satinato  
Black satin glass painted top and base

## BASE E PIANO/BASE AND TOP



Cristallo brillante/satinato nei colori del campionario  
Glass bright/satin version as per samples



Cristallo spazzolato "Cashmere" gold grey  
"Cashmere" gold grey brushed glass



Cristallo spazzolato "Cashmere" anthracite  
"Cashmere" anthracite brushed glass



Cristallo verniciato bronzo patinato  
Patinated bronze painted glass



# Hanami

Pietro Russo / 2022

Consolle in legno laccato opaco con piano in legno laccato lucido. Colori disponibili: "Bianco Camargue", "Sabbia del Nilo", "Rosa Jaipur", "Rosso Persia", "Bordeaux Etruria", "Verde Provenza", "Blu Pacifico", "Grigio Londra", "Nero Giza". Piedini regolabili in ottone lucido. Su richiesta "Versione RAL" in legno laccato nel colore RAL richiesto dal cliente. Questa versione prevede tempi di produzione diversi dallo standard che verranno confermati al momento dell'ordine.

Console in opaque lacquered wood with glossy lacquered wooden top. Available colours: "Bianco Camargue", "Sabbia del Nilo", "Rosa Jaipur", "Rosso Persia", "Bordeaux Etruria", "Verde Provenza", "Blu Pacifico", "Grigio Londra", "Nero Giza". Adjustable feet in bright brass. "RAL version" in RAL customer's lacquered wood on request. For this version the production time is different and will be confirmed upon the order.

! La "Versione RAL" prevede tempi di produzione diversi dallo standard che verranno confermati al momento dell'ordine.

! For "RAL Version" the production time is different and will be confirmed upon the order.



**Cm**

140 x 42 x 90  
160 x 42 x 90

**Inches**

55 1/4" x 16 3/4" x 35 1/2"  
63" x 16 3/4" x 35 1/2"

For technical drawing / p. 368

Pricelist 2023 / p. 225  
Homescapes, gentle attitude / p. 69

**STRUTTURA/STRUCTURE**



Legno laccato lucido/opaco  
"Bianco Camargue"  
"Bianco Camargue" glossy/  
opaque lacquered wood



Legno laccato lucido/opaco  
"Sabbia del Nilo"  
"Sabbia del Nilo" glossy/  
opaque lacquered wood

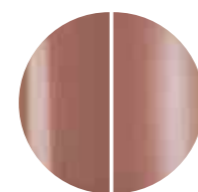

Legno laccato lucido/opaco  
"Rosso Persia"  
"Rosso Persia" glossy/  
opaque lacquered wood

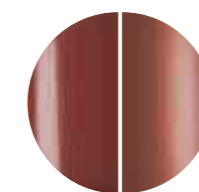

Legno laccato lucido/opaco  
"Bordeaux Etruria"  
"Bordeaux Etruria" glossy/  
opaque lacquered wood

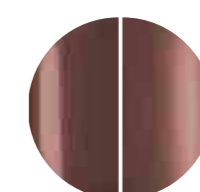

Legno laccato lucido/opaco  
"Verde Provenza"  
"Verde Provenza" glossy/  
opaque lacquered wood

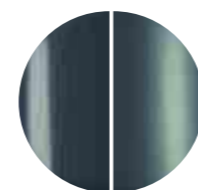

Legno laccato lucido/opaco  
"Blu Pacifico"  
"Blu Pacifico" glossy/  
opaque lacquered wood

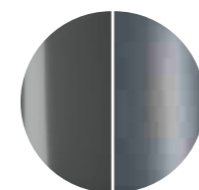

Legno laccato lucido/opaco  
"Grigio Londra"  
"Grigio Londra" glossy/  
opaque lacquered wood



Legno laccato lucido/opaco  
"Nero Giza"  
"Nero Giza" glossy/  
opaque lacquered wood



"Versione RAL"  
"RAL Version"

▲ HANAMI  
Struttura in legno laccato lucido "Verde Provenza"  
"Verde Provenza" glossy lacquered wood structure



# Sensei Console

Tollgard+Castellani/2023

Consolle con struttura in metallo e piano in legno laccato "deep black". Ripiano e schienale in frassino tinto nero poro aperto. In appoggio sul top in legno, piano in cristallo 12mm molato a mezzo toro nella finitura esclusiva "Rosso Marte" oppure retroverniciato brillante nei colori del campionario. Disponibile anche piano in marmo 20mm Calacatta Vagli Oro lucido naturale, Ceppo di Gré® spazzolato, Arabescato Orobico Rosso satinato, Bianco Carrara Gioia satinato oppure Dover White satinato. Disponibile su richiesta versione lounge cm 65h. Su richiesta vassoio portaoggetti in metallo rivestito in pelle fard nei colori del campionario.

## NOTE TECNICHE SUI MATERIALI

**MARMO** | Il marmo è un materiale naturale di origine sedimentaria che può presentare particolarità come venature, lievi irregolarità superficiali, colorazioni differenti e cristallizzazioni. Queste peculiarità sono da attribuirsi alla naturalezza del materiale e non sono da considerarsi difetti ma caratteristiche tipiche del marmo. Ogni prodotto risulterà unico, esclusivo e non replicabile. I nostri marmi vengono trattati con un prodotto idrorepellente che permette una maggiore protezione della superficie stessa, aumentando l'impermeabilità. Questo trattamento non esclude la vulnerabilità del marmo alle sostanze acide.

Console with "deep black" lacquered metal structure and wooden top. Black open pore stained ash shelf and back. Resting on the wooden top, 12mm glass top with half bull-nose grinding in the exclusive finish "Rosso Marte" or painted as per samples in the bright version. Also available with 20mm natural polished Calacatta Vagli Oro marble, brushed Ceppo di Gré®, satin Arabescato Orobico Rosso, satin Bianco Carrara Gioia or satin Dover White.

Lounge version height cm 65, available on request.

Metal accessories tray covered by leather fard as per samples, on request.

## TECHNICAL INFORMATION ON THE MATERIALS

**MARBLE** | The marble is a natural material of sedimentary origin that can present particularities such as veins, slight surface irregularities, different colors and crystallizations. These peculiarities are to be attributed to the naturalness of the material and are not to be considered defects but typical characteristics of marble. Each product will be unique, exclusive and non-replicable. Our marbles are treated with water-repellent products which affords greater protection to the surface of the marble, improving its impermeability. This treatment doesn't exclude the vulnerability of the marble to acid substances.



## Cm

### Piano in cristallo

150 x 35 x 65

150 x 35 x 80

### Piano in marmo

180 x 35 x 65

180 x 35 x 80

### Vassoio portaoggetti

45 x 20 x 4

## Inches

### Glass top

59¼" x 14" x 25¾"

59¼" x 14" x 31½"

### Marble top

71" x 14" x 25¾"

71" x 14" x 31½"

### Accessories tray

17¾" x 8" x 1¾"

[For technical drawing / p. 369](#)

[Pricelist 2023 / p. 226](#)

## STRUTTURA/STRUCTURE



Metallo/legno laccato  
"deep black"  
"deep black" lacquered  
metal/wood

## RIPIANO E SCHIENALE SHELF AND BACK

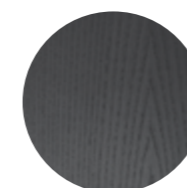

Frassino tinto  
nero poro aperto  
Black open pore  
stained ash

## PIANO/TOP



Cristallo "Rosso Marte"  
"Rosso Marte" glass



Sample box

Cristallo brillante  
nei colori del campionario  
Bright glass version  
as per samples



Marmo lucido naturale  
Calacatta Vagli Oro  
Natural polished Calacatta  
Vagli Oro marble

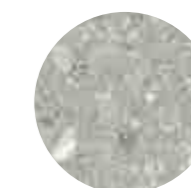

Ceppo di Gré® spazzolato  
Brushed Ceppo di Gré®

## VASSOIO PORTAOGGETTI ACCESSORIES TRAY



Sample box  
COVERS

Metallo rivestito in pelle fard  
nei colori del campionario  
Metal covered leather fard  
as per samples



Marmo Arabescato  
Orobico Rosso satinato  
Arabescato Orobico  
Rosso satin marble

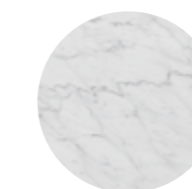

Marmo spazzolato  
Bianco Carrara Gioia  
Brushed Bianco Carrara  
Gioia marble



Marmo satinato  
Dover white  
Satin Dover white marble

## ▲ SENSEI CONSOLE

Piano in cristallo "RossoMarte"/ Vassoio portaoggetti in fard silt 2324  
"Rosso Marte" glass top/ Fard silt 2324 accessories tray



# Tama Console

Carlo Colombo / 2016

Consolle con cassetti in frassino tinto nero a poro aperto con parti metalliche laccate ottone satinato. Top in cristallo 6mm temperato retroverniciato liquirizia brillante.

Console with black open pore stained ash drawers and satin brass lacquered metal parts. 6mm bright liquorice painted tempered glass top.



**Cm**  
120 x 36 x 83  
140 x 36 x 83

**Inches**  
47 1/4" x 14 1/4" x 32 3/4"  
55 1/4" x 14 1/4" x 32 3/4"

For technical drawing / p. 369

Pricelist 2023 / p. 227  
Homescapes, sense of materials / p. 108

STRUTTURA/STRUCTURE

PIANO/TOP

PARTI METALLICHE/  
METAL PARTS

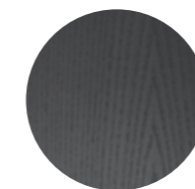

**Frassino tinto  
nero poro aperto**  
Black open pore  
stained ash

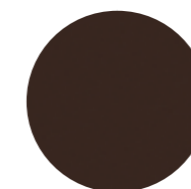

**Cristallo liquirizia  
brillante**  
Bright liquorice  
painted glass



**Ottone satinato**  
Satin brass

**07**

**Consolle / Consoles**  
**TECHNICAL MODULE**



**Athus Console** | Oscar e Gabriele Buratti, 2013

Product information / p. 356

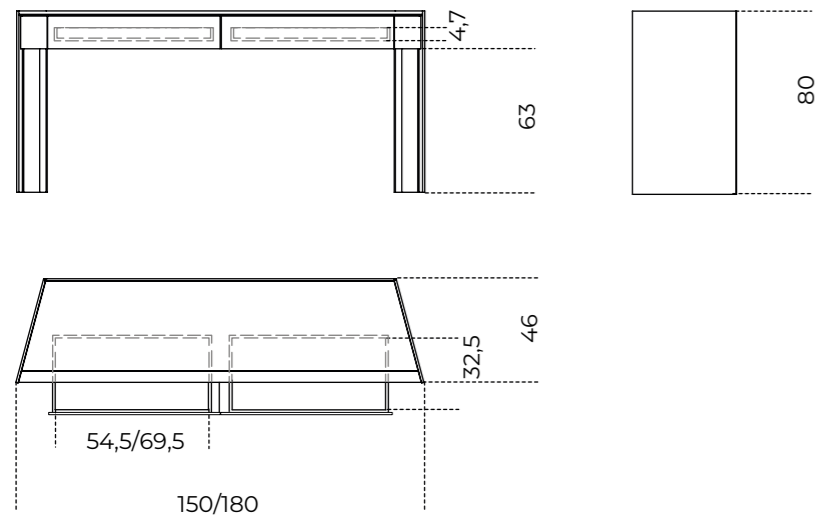

**Dolm Console** | Oscar e Gabriele Buratti, 2013

Product information / p. 358

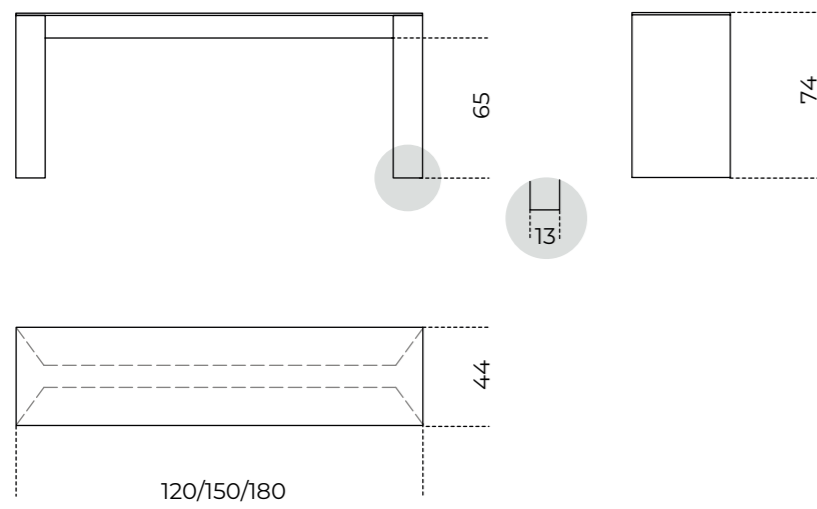

**Hanami** | Pietro Russo, 2022

Product information / p. 360

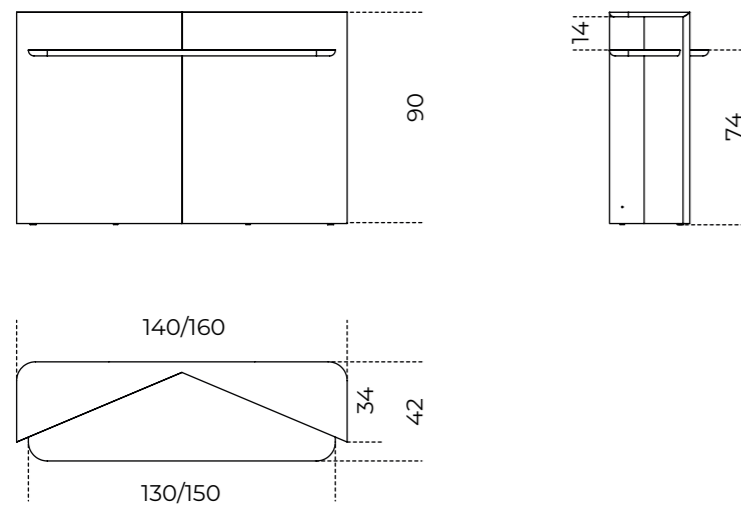

**Sensei Console** | Tollgard + Castellani, 2023

Product information / p. 362

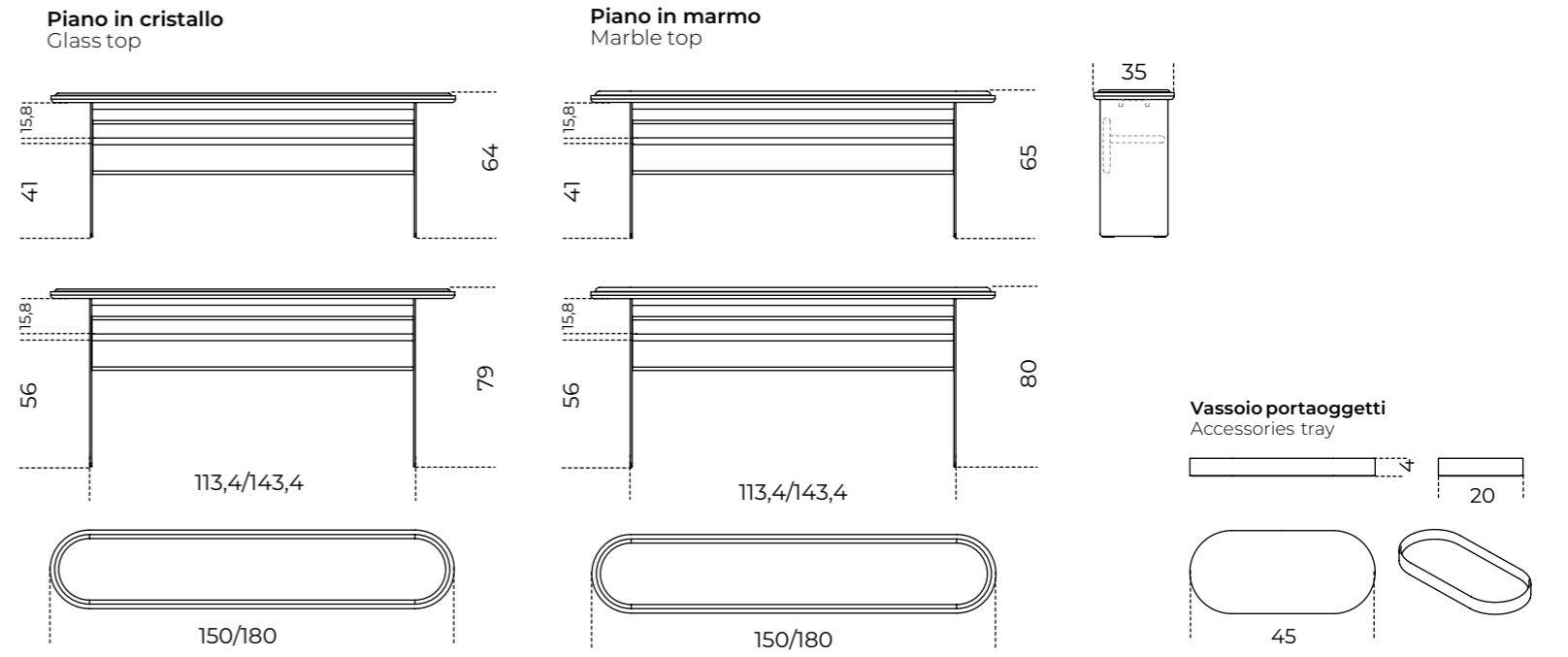

**Tama Console** | Carlo Colombo, 2016

Product information / p. 364

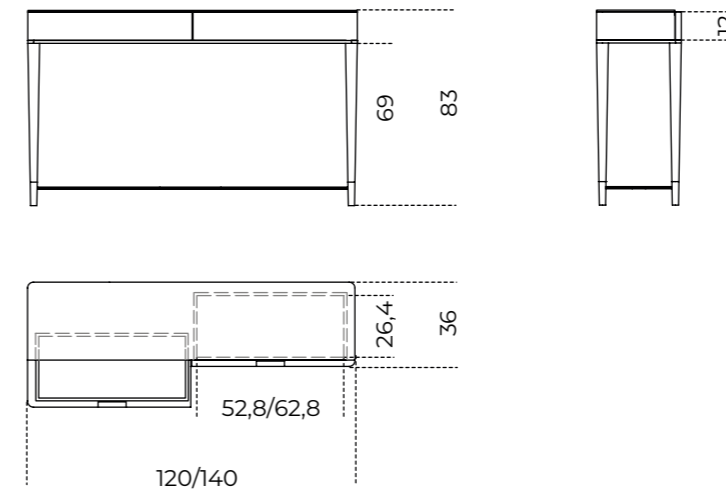

## **08** Contenitori / Storage Units

- [372](#) **5th Avenue**
- [374](#) **5th Avenue Crédence**
- [376](#) **Athus**
- [378](#) **Diedro**
- [382](#) **Gastone**
- [384](#) **Gastone Low**
- [386](#) **Hide&Seek**
- [390](#) **Hide&Seek Door**
- [392](#) **Kumi**
- [394](#) **Pandora**
- [396](#) **Pandora Cashmere**
- [398](#) **Pandora Craquelé**
- [400](#) **Pandora Light**
- [402](#) **Soda**
- [406](#) **Stami Sideboard**
- [408](#) **Tama**
- [410](#) **Tama Crédence**
- [412](#) **Tama Vitrine**
  
- [414](#) **Informazioni tecniche/  
[Technical informations](#)**



# 5th Avenue

Marcello Pozzi / 2019

Madia in legno rivestita in acciaio inox "supermirror" nella finitura cromo nero con listelli in massello tinto nero a poro aperto.  
 Base in frassino tinto nero a poro aperto e rivestita internamente in acciaio inox "supermirror" nella finitura cromo nero.  
 Top in cristallo "grigio Italia" 12 mm bisellato retroverniciato nero brillante con dettaglio in ottone satinato.  
 Dotata di ripiano interno in cristallo extralight 8mm e schienale interno in specchio 6mm.

## NOTE TECNICHE SUI MATERIALI

**CRISTALLO** | Le finiture esclusive, risultato della lavorazione manuale realizzata sul cristallo, possono presentare striature e differenze cromatiche. Queste caratteristiche non devono essere considerate difetti ma elementi distintivi del processo artigianale che esaltano la bellezza e la peculiarità del pezzo unico.

Wooden unit covered by "supermirror" stainless steel in the black chrome finish with black stained open pore solid wood strips.  
 Base in black open pore stained ash and internal part covered by "supermirror" stainless steel in the black chrome finish.  
 Top with bevel in 12mm bright black painted smoked "grigio Italia" glass with satin brass detail.  
 Supplied with 8mm extralight glass shelf and 6mm mirrored glass inside back.

## TECHNICAL INFORMATION ON THE MATERIALS

**GLASS** | Exclusive finishes, resulting from the craftsmanship on the glass, may show streaks and chromatic differences. These characteristics should not be considered imperfections but distinctive evidence of the hand-made process that enhance the beauty and peculiarity of the unique piece.



For technical drawing / p. 416

Pricelist 2023 / p. 241  
 Homescapes, sense of materials / p. 18  
 Homescapes, embracing beauty / p. 28  
 Homescapes, gentle attitude / p. 37

**Cm**  
 110 x 47 x 122

**Inches**  
 43½" x 18¾" x 48¾"

**STRUTTURA E BASE/  
 STRUCTURE AND BASE**

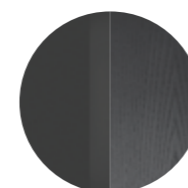

Cromo nero "supermirror"/  
 Tinto nero a poro aperto  
 Black chrome "supermirror"/  
 Black open pore stained  
 ash

**PIANO/TOP**

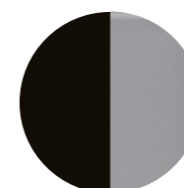

Cristallo "grigio Italia"  
 retroverniciato  
 nero brillante  
 Bright black painted  
 smoked "grigio Italia" glass

**DETTAGLI/DETAILS**



Ottone satinato  
 Satin brass

**RIPIANO INTERNO /  
 INSIDE SHELF**



Cristallo extralight  
 Extralight glass

**SCHIENALE INTERNO /  
 INSIDE BACK**



Specchio  
 Mirror



• 5TH AVENUE CRÉDENCE  
Versione con vano interno A  
Version with A compartment

# 5th Avenue Crédence

Marcello Pozzi / 2020

Madia in legno rivestita in acciaio inox "supermirror" nella finitura cromo nero con listelli in massello tinto nero a poro aperto. Base in frassino tinto nero a poro aperto e rivestita internamente in acciaio inox "supermirror" nella finitura cromo nero. Top in cristallo "grigio Italia" 12mm bisellato retroverniciato nero brillante con dettaglio in ottone satinato. Schienale interno in specchio 6mm.

Configurazione standard con vani versione A (n. 2 vani per la misura cm 190 e n. 3 vani per la misura cm 280). Disponibili vani B e C con supplemento. Possibilità di versione bifacciale con apertura delle ante fronte o retro, da specificare al momento dell'ordine.

Wooden unit covered by "supermirror" stainless steel in the black chrome finish with black stained open pore solid wood strips. Base in black open pore stained ash and internal part covered by "supermirror" stainless steel in the black chrome finish. Top with bevel in 12mm bright black painted smoked "grigio Italia" glass with satin brass detail. 6mm mirrored glass inside back.

Standard configuration with version A compartments (n. 2 compartments for the size cm 190 and n. 3 compartments for the size cm 280). Compartments B and C available with extra charge. Double-sided version possible with front or rear doors opening, to be specified when ordering.

## NOTE TECNICHE SUI MATERIALI

**CRISTALLO** | Le finiture esclusive, risultato della lavorazione manuale realizzata sul cristallo, possono presentare striature e differenze cromatiche. Queste caratteristiche non devono essere considerate difetti ma elementi distintivi del processo artigianale che esaltano la bellezza e la peculiarità del pezzo unico.

## TECHNICAL INFORMATION ON THE MATERIALS

**GLASS** | Exclusive finishes, resulting from the craftsmanship on the glass, may show streaks and chromatic differences. These characteristics should not be considered imperfections but distinctive evidence of the hand-made process that enhance the beauty and peculiarity of the unique piece.



**Cm**  
190 x 47 x 74  
280 x 47 x 74

**Inches**  
75" x 18¾" x 29¼"  
110¾" x 18¾" x 29¼"

[For technical drawing / p. 416](#)

[Pricelist 2023 / p. 242](#)  
[Homescapes, embracing beauty / p. 25](#)  
[Homescapes, gentle attitude / p. 39](#)

**STRUTTURA E BASE/  
STRUCTURE AND BASE**

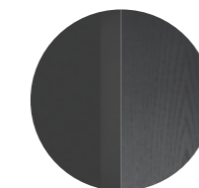

Cromo nero "supermirror"/  
Tinto nero a poro aperto  
Black chrome "supermirror"/  
Black open pore stained  
ash

**PIANO/TOP**

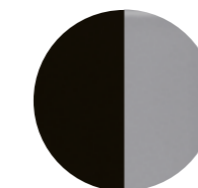

Cristallo "grigio Italia"  
retroverniciato  
nero brillante  
Bright black painted  
smoked "grigio Italia" glass

**DETTAGLI/DETAILS**



Ottone satinato  
Satin brass

**RIPIANO INTERNO /  
INSIDE SHELF**



Cristallo extralight  
Extralight glass

**SCHIENALE INTERNO /  
INSIDE BACK**



Specchio  
Mirror



▲ ATHUS  
Piano in marmo lucido naturale Stardust grey  
Natural polished Stardust grey marble top

# Athus

Oscar e Gabriele Buratti / 2017

Madia in frassino tinto nero a poro aperto. Dettagli in metallo verniciato bronzo patinato. Top in marmo lucido naturale Stardust Grey o Sahara Noir. Disponibile anche in cristallo temperato 6mm retroverniciato nero brillante. Dotata di ripiano interno in cristallo extralight 10mm biselato temperato. Schienali interni in specchio 6mm. Cassetti con fondo in pelle scamosciata e apertura push and pull solo per versioni 48h e 75,5h.

Sideboard in black open pore stained ash. Patinated bronze lacquered metal details. Natural polished Stardust Grey or Sahara Noir marble top. Also available in 6mm tempered bright black painted glass. Supplied with 10mm tempered and bevelled extralight inside glass shelf. 6mm mirror inside backs. Push-pull drawers with suede bottom just for versions 48h and 75,5h.

## NOTE TECNICHE SUI MATERIALI

**MARMO** | Il marmo è un materiale naturale di origine sedimentaria che può presentare particolarità come venature, lievi irregolarità superficiali, colorazioni differenti e cristallizzazioni. Queste peculiarità sono da attribuirsi alla naturalezza del materiale e non sono da considerarsi difetti ma caratteristiche tipiche del marmo. Ogni prodotto risulterà unico, esclusivo e non replicabile. I nostri marmi vengono trattati con un prodotto idrorepellente che permette una maggiore protezione della superficie stessa, aumentando l'impermeabilità. Questo trattamento non esclude la vulnerabilità del marmo alle sostanze acide. Il marmo Sahara Noir viene trattato con vernice al poliestere per aumentare la resistenza del piano.

## TECHNICAL INFORMATION ON THE MATERIALS

**MARBLE** | The marble is a natural material of sedimentary origin that can present particularities such as veins, slight surface irregularities, different colors and crystallizations. These peculiarities are to be attributed to the naturalness of the material and are not to be considered defects but typical characteristics of marble. Each product will be unique, exclusive and non-replicable. Our marbles are treated with water-repellent products which affords greater protection to the surface of the marble, improving its impermeability. This treatment doesn't exclude the vulnerability of the marble to acid substances. The Sahara Noir marble is treated with polyester-coated finish to increase the resistance of the top.



### Cm

125,5 x 57 x 136,5  
155 x 57 x 136,5  
250 x 58 x 75,5  
300 x 57 x 48

### Inches

49½" x 22½" x 53¾"  
61¼" x 22½" x 53¾"  
98½" x 23" x 29¾"  
118¼" x 22½" x 19"

For technical drawing / p. 417

Pricelist 2023 / p. 244

Homescapes, sense of materials / p. 54  
Homescapes, intimate portraits / p. 39, 41

## STRUTTURA/STRUCTURE

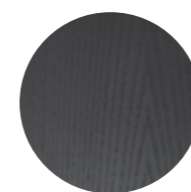

Frassino tinto  
nero a poro aperto  
Black open pore  
stained ash

## RIPIANO INTERNO / INSIDE SHELF



Cristallo extralight  
Extralight glass

## DETTAGLI/DETAILS



Metallo verniciato  
bronzo patinato  
Patinated bronze  
lacquered metal

## SCHIENALE INTERNO / INSIDE BACK



Specchio  
Mirror

## PIANO/TOP

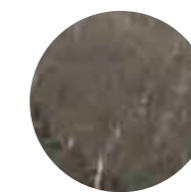

Marmo lucido naturale  
Stardust grey  
Natural polished  
Stardust grey marble



Marmo lucido naturale  
Sahara Noir  
Natural polished  
Sahara Noir marble

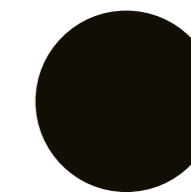

Cristallo retroverniciato  
nero brillante  
Bright black painted glass

## CASSETTI/DRAWERS VERSIONE 48 - 75,5 CM



Pelle scamosciata  
Suede

# Diedro

Pietro Russo / 2022

Contenitore pensile in frassino tinto nero a poro aperto oppure legno laccato lucido o opaco. Colori disponibili: "Bianco Camargue", "Sabbia del Nilo", "Rosa Jaipur", "Rosso Persia", "Bordeaux Etruria", "Verde Provenza", "Blu Pacifico", "Grigio Londra", "Nero Giza".

Disponibile versione freestanding con struttura in metallo nero bronzato per il contenitore in frassino tinto nero o laccata nello stesso colore del contenitore per la versione laccata.

Mobile altezza cm 120 dotato di due ripiani in cristallo extralight 8mm temperato.

Suspended unit in black open pore stained ash or glossy or opaque lacquered wood. Available colours: "Bianco Camargue", "Sabbia del Nilo", "Rosa Jaipur", "Rosso Persia", "Bordeaux Etruria", "Verde Provenza", "Blu Pacifico", "Grigio Londra", "Nero Giza".

Available freestanding version with bronzed black metal structure for the black stained ash unit or lacquered in the same colour of the unit for the lacquered version. Unit height cm 120 supplied with two 8mm tempered extralight glass shelves.



## Cm

### Versione pensile

131 x 47 x 120  
184 x 43 x 40  
305 x 43 x 40  
365.5 x 43 x 40

### Versione freestanding

131 x 47 x 153  
184 x 43 x 73  
305 x 43 x 73

## Inches

### Suspended version

51¾" x 18¾" x 47¼"  
72½" x 17" x 15¾"  
120¼" x 17" x 15¾"  
144" x 17" x 15¾"

### Freestanding version

51¾" x 18¾" x 60¼"  
72½" x 17" x 28¾"  
120¼" x 17" x 28¾"

For technical drawing / p. 417

Pricelist 2023 / p. 245  
Homescapes, gentle attitude / pp. 81, 84, 85

## VERSIONE PENSILE / SUSPENDED VERSION CONTENITORE LEGNO / WOODEN UNIT

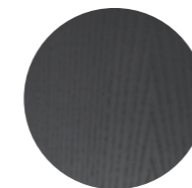

Frassino tinto  
nero a poro aperto  
Black open pore stained ash



Legno laccato lucido/opaco  
"Bianco Camargue"  
"Bianco Camargue" glossy/  
opaque lacquered wood

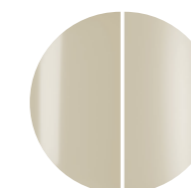

Legno laccato lucido/opaco  
"Sabbia del Nilo"  
"Sabbia del Nilo" glossy/  
opaque lacquered wood

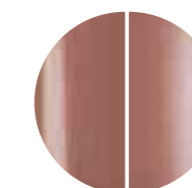

Legno laccato lucido/opaco  
"Bianco Camargue"  
"Bianco Camargue" glossy/  
opaque lacquered wood

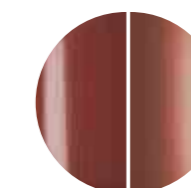

Legno laccato lucido/opaco  
"Rosso Persia"  
"Rosso Persia" glossy  
/opaque lacquered wood

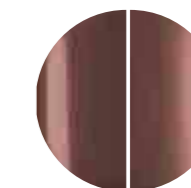

Legno laccato lucido/opaco  
"Bordeaux Etruria"  
"Bordeaux Etruria" glossy/  
opaque lacquered wood

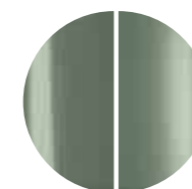

Legno laccato lucido/opaco  
"Verde Provenza"  
"Verde Provenza" glossy/  
opaque lacquered wood

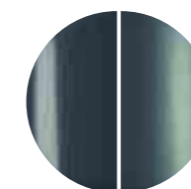

Legno laccato lucido/opaco  
"Blu Pacifico"  
"Blu Pacifico" glossy/  
opaque lacquered wood

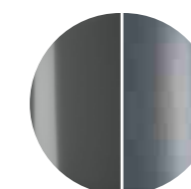

Legno laccato lucido/opaco  
"Grigio Londra"  
"Grigio Londra" glossy  
/opaque lacquered wood



Legno laccato lucido/opaco  
"Nero Giza"  
"Nero Giza" glossy/  
opaque lacquered wood



**Cm**  
**Versione freestanding**  
 131 x 47 x 153  
 184 x 43 x 73  
 305 x 43 x 73

**Inches**  
**Freestanding version**  
 51¾" x 18¾" x 60¾"  
 72½" x 17" x 28¾"  
 120¾" x 17" x 28¾"

For technical drawing / p. 417

Pricelist 2023 / p. 245  
 Homescapes, gentle attitude / pp. 81, 84, 85

VERSIONE FREESTANDING / FREESTANDING VERSION

**CONTENITORE LEGNO /  
WOODEN UNIT**

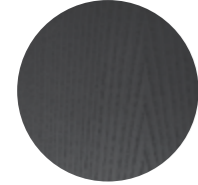

**Frassino tinto nero poro  
aperto**  
 Black open pore stained  
 ash

**STRUTTURA METALLO /  
METAL STRUCTURE**

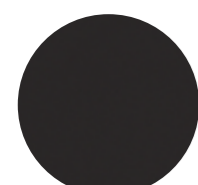

**Metallo nero bronzato**  
 Bronzed black metal

**VERSIONE LACCATO / LACQUERED VERSION**  
**STRUTTURA METALLO E CONTENITORE LEGNO NELLO STESSO COLORE / METAL STRUCTURE AND WOODEN UNIT IN THE SAME COLOUR**



**Laccato lucido/opaco**  
**"Bianco Camargue"**  
 Glossy/ opaque lacquered  
 "Bianco Camargue"



**Legno laccato lucido/opaco**  
**"Sabbia del Nilo"**  
 "Sabbia del Nilo" glossy/  
 opaque lacquered wood

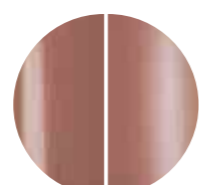

**Laccato lucido/opaco**  
**"Bianco Camargue"**  
 Glossy/ opaque lacquered  
 "Bianco Camargue"

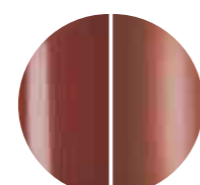

**Laccato lucido/opaco**  
**"Rosso Persia"**  
 Glossy/ opaque lacquered  
 "Rosso Persia"

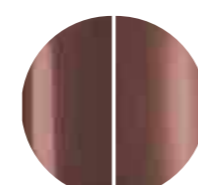

**Laccato lucido/opaco**  
**"Bordeaux Etruria"**  
 Glossy/ opaque lacquered  
 "Bordeaux Etruria"

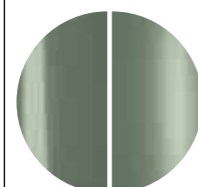

**Laccato lucido/opaco**  
**"Verde Provenza"**  
 Glossy/ opaque lacquered  
 "Verde Provenza"

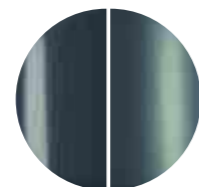

**Laccato lucido/opaco**  
**"Blu Pacifico"**  
 Glossy/ opaque lacquered  
 "Blu Pacifico"

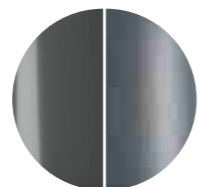

**Laccato lucido/opaco**  
**"Grigio Londra"**  
 Glossy/ opaque lacquered  
 "Grigio Londra"



**Laccato lucido/opaco**  
**"Nero Giza"**  
 Glossy/ opaque lacquered  
 "Nero Giza"



▲ **DIEDRO**  
 Versione freestanding struttura e contenitore laccato lucido "Verde Provenza"  
 Freestanding version structure and unit glossy lacquered "Verde Provenza"



# Gastone

Carlo Colombo / 2023

Madia in legno laccato lucido o opaco nei colori "Bianco Camargue", "Sabbia del Nilo", "Rosa Jaipur", "Rosso Persia", "Bordeaux Etruria", "Verde Provenza", "Blu Pacifico", "Grigio Londra", "Nero Giza". Parti interne "herringbone grey".  
Top nella stessa finitura della madia.

Su richiesta disponibile top in marmo Travertino Romano spazzolato naturale (non resinato) oppure in Ceppo di Gré® spazzolato.

Su richiesta mensola superiore sagomata in cristallo extralight 8mm temperato. Il modulo ad ante può essere fornito con ripiano interno in cristallo extralight e il modulo cassettone può essere fornito di cassetto interno. Disponibile in composizioni predefinite.

Sideboard in glossy or opaque lacquered wood. Available colours: "Bianco Camargue", "Sabbia del Nilo", "Rosa Jaipur", "Rosso Persia", "Bordeaux Etruria", "Verde Provenza", "Blu Pacifico", "Grigio Londra", "Nero Giza". Internal part in "herringbone grey" colour. Top in the same finish as the sideboard.

Available, on request, natural brushed Travertino Romano (not treated with resin) or brushed Ceppo di Gré® top.

Upon request 8mm extralight tempered shaped upper shelf. The module with doors can be supplied with an extralight glass internal shelf and the module with big drawer can be supplied with an internal drawer. Available in standard compositions.

## NOTE TECNICHE SUI MATERIALI

**CEPPO DI GRÉ® - MARMO** | Il marmo è un materiale naturale di origine sedimentaria che può presentare particolarità come venature, lievi irregolarità superficiali, colorazioni differenti e cristallizzazioni. Queste peculiarità sono da attribuirsi alla naturalezza del materiale e non sono da considerarsi difetti ma caratteristiche tipiche del marmo. Ogni prodotto risulterà unico, esclusivo e non replicabile. I nostri marmi vengono trattati con un prodotto idrorepellente che permette una maggiore protezione della superficie stessa, aumentando l'impermeabilità. Questo trattamento non esclude la vulnerabilità del marmo alle sostanze acide.

## TECHNICAL INFORMATION ON THE MATERIALS

**CEPPO DI GRÉ® - MARBLE** | The marble is a natural material of sedimentary origin that can present particularities such as veins, slight surface irregularities, different colors and crystallizations. These peculiarities are to be attributed to the naturalness of the material and are not to be considered defects but typical characteristics of marble. Each product will be unique, exclusive and non-replicable. Our marbles are treated with water-repellent products which affords greater protection to the surface of the marble, improving its impermeability. This treatment doesn't exclude the vulnerability of the marble to acid substances.



**Cm**  
205 x 55 x 73,5  
245 x 55 x 73,5

**Inches**  
80¾" x 21¾" x 29"  
96½" x 21¾" x 29"

For technical drawing / p. 418

Pricelist 2023 / p. 246

## CONTENITORE E TOP / SIDEBOARD AND TOP



Legno laccato lucido/opaco  
"Bianco Camargue"  
"Bianco Camargue" glossy/  
opaque lacquered wood



Legno laccato lucido/opaco  
"Sabbia del Nilo"  
"Sabbia del Nilo" glossy/  
opaque lacquered wood



Legno laccato lucido/opaco  
"Rosso Persia"  
"Rosso Persia" glossy/  
opaque lacquered wood

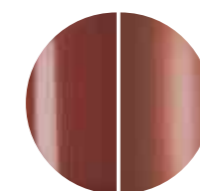

Legno laccato lucido/opaco  
"Bordeaux Etruria"  
"Bordeaux Etruria" glossy/  
opaque lacquered wood

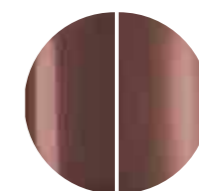

Legno laccato lucido/opaco  
"Herringbone grey"  
"Herringbone grey" glossy/  
opaque lacquered wood

## PARTI INTERNE/ INTERNAL PARTS



"Herringbone grey"  
"Herringbone grey"

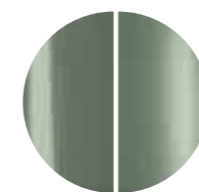

Legno laccato lucido/opaco  
"Verde Provenza"  
"Verde Provenza" glossy/  
opaque lacquered wood

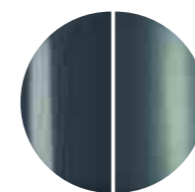

Legno laccato lucido/opaco  
"Blu Pacifico"  
"Blu Pacifico" glossy/  
opaque lacquered wood

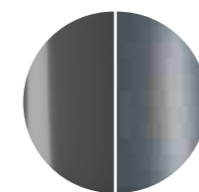

Legno laccato lucido/opaco  
"Grigio Londra"  
"Grigio Londra" glossy/  
opaque lacquered wood

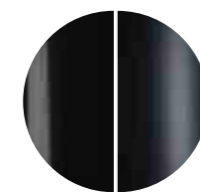

Legno laccato lucido/opaco  
"Nero Giza"  
"Nero Giza" glossy/  
opaque lacquered wood

## PIANO MARMO (OPZIONALE)/ MARBLE TOP (OPTIONAL)



Travertino Romano  
spazzolato naturale  
Natural brushed  
Travertino Romano

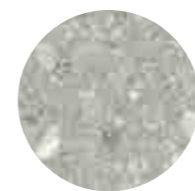

Ceppo di Gré® spazzolato  
Brushed Ceppo di Gré®



Cristallo extralight  
Extralight glass

## MENSOLA SUPERIORE SAGOMATA (OPZIONALE) SHAPED UPPER SHELF (OPTIONAL)

## RIPIANO INTERNO/INSIDE SHELF PER MODULO AD ANTE/ FOR DOORS MODULE



Cristallo extralight  
Extralight glass

▲ **GASTONE**  
Struttura in legno laccato lucido "Sabbia del Nilo", parti interne "herringbone grey"  
"Sabbia del Nilo" glossy lacquered wood structure, Internal part in "herringbone grey" colour



# Gastone Low

Carlo Colombo / 2023

Mobile contenitore in legno laccato lucido o opaco nei colori "Bianco Camargue", "Sabbia del Nilo", "Rosa Jaipur", "Rosso Persia", "Bordeaux Etruria", "Verde Provenza", "Blu Pacifico", "Grigio Londra", "Nero Giza". Appoggio a terra su base regolabile. Parti interne color "herringbone grey". Top nella stessa finitura della madia. Su richiesta disponibile top in marmo Travertino Romano spazzolato naturale (non resinato) oppure in Ceppo di Gré® spazzolato.

Su richiesta mensola superiore sagomata in cristallo extralight 8mm temperato. Il modulo ad ante può essere fornito con ripiano interno in cristallo extralight e il modulo cassettoni può essere fornito di cassetto interno. Disponibile in composizioni predefinite.

Sideboard in glossy or opaque lacquered wood. Available colours: "Bianco Camargue", "Sabbia del Nilo", "Rosa Jaipur", "Rosso Persia", "Bordeaux Etruria", "Verde Provenza", "Blu Pacifico", "Grigio Londra", "Nero Giza". Floor base support on adjustable base. Internal part in "herringbone grey" colour.

Top in the same finish as the sideboard. Available, on request, natural brushed Travertino Romano (not treated with resin) or brushed Ceppo di Gré® top.

Upon request 8mm extralight tempered shaped upper shelf.

The module with doors can be supplied with an extralight glass internal shelf and the module with big drawer can be supplied with an internal drawer. Available in standard compositions.

## NOTE TECNICHE SUI MATERIALI

**CEPPO DI GRÉ® - MARMO** | Il marmo è un materiale naturale di origine sedimentaria che può presentare particolarità come venature, lievi irregolarità superficiali, colorazioni differenti e cristallizzazioni. Queste peculiarità sono da attribuirsi alla naturalezza del materiale e non sono da considerarsi difetti ma caratteristiche tipiche del marmo. Ogni prodotto risulterà unico, esclusivo e non replicabile. I nostri marmi vengono trattati con un prodotto idrorepellente che permette una maggiore protezione della superficie stessa, aumentando l'impermeabilità. Questo trattamento non esclude la vulnerabilità del marmo alle sostanze acide.

## TECHNICAL INFORMATION ON THE MATERIALS

**CEPPO DI GRÉ® - MARBLE** | The marble is a natural material of sedimentary origin that can present particularities such as veins, slight surface irregularities, different colors and crystallizations. These peculiarities are to be attributed to the naturalness of the material and are not to be considered defects but typical characteristics of marble. Each product will be unique, exclusive and non-replicable.

Our marbles are treated with water-repellent products which affords greater protection to the surface of the marble, improving its impermeability.

This treatment doesn't exclude the vulnerability of the marble to acid substances.



### Cm

205 x 55 x 57  
245 x 55 x 57  
406 x 55 x 57  
446 x 55 x 57  
486 x 55 x 57

### Inches

80 3/4" x 21 3/4" x 22 1/2"  
96 1/2" x 21 3/4" x 22 1/2"  
160" x 21 3/4" x 22 1/2"  
175 1/4" x 21 3/4" x 22 1/2"  
191 1/2" x 21 3/4" x 22 1/2"

[For technical drawing / p. 419-422](#)

[Pricelist 2023 / p. 248](#)

## CONTENITORE E TOP / SIDEBOARD AND TOP



Legno laccato lucido/opaco  
"Bianco Camargue"  
"Bianco Camargue" glossy/  
opaque lacquered wood



Legno laccato lucido/opaco  
"Sabbia del Nilo"  
"Sabbia del Nilo" glossy/  
opaque lacquered wood

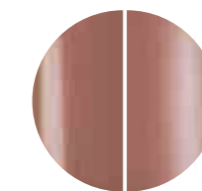

Legno laccato lucido/opaco  
"Rosso Persia"  
"Rosso Persia" glossy/  
opaque lacquered wood

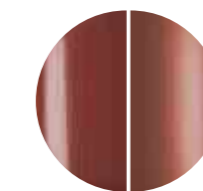

Legno laccato lucido/opaco  
"Bordeaux Etruria"  
"Bordeaux Etruria" glossy/  
opaque lacquered wood

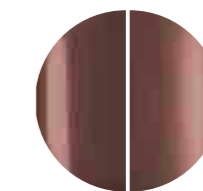

Parti interne/  
"Herringbone grey"  
"Herringbone grey"

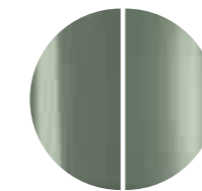

Legno laccato lucido/opaco  
"Verde Provenza"  
"Verde Provenza" glossy/  
opaque lacquered wood

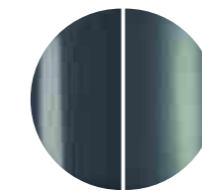

Legno laccato lucido/opaco  
"Blu Pacifico"  
"Blu Pacifico" glossy/  
opaque lacquered wood

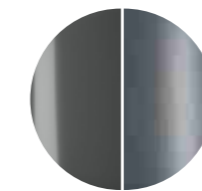

Legno laccato lucido/opaco  
"Grigio Londra"  
"Grigio Londra" glossy/  
opaque lacquered wood



Legno laccato lucido/opaco  
"Nero Giza"  
"Nero Giza" glossy/  
opaque lacquered wood

## PIANO MARMO (OPZIONALE)/ MARBLE TOP (OPTIONAL)



Travertino Romano  
spazzolato naturale  
Natural brushed  
Travertino Romano



Ceppo di Gré® spazzolato  
Brushed Ceppo di Gré®



Cristallo extralight  
Extralight glass

## MENSOLA SUPERIORE SAGOMATA (OPZIONALE) SHAPED UPPER SHELF (OPTIONAL)

## RIPIANO INTERNO/INSIDE SHELF PER MODULO AD ANTE/ FOR DOORS MODULE



Cristallo extralight  
Extralight glass



▲ HIDE&SEEK  
Struttura in legno laccato lucido "Rosso Persia"  
"Rosso Persia" glossy lacquered wood structure

# Hide&Seek

Pietro Russo / 2021

Contenitore con struttura, ripiani e mezz-cilindri in legno laccato lucido o opaco. Colori disponibili: "Bianco Camargue", "Sabbia del Nilo", "Rosa Jaipur", "Rosso Persia", "Bordeaux Etruria", "Verde Provenza", "Blu Pacifico", "Grigio Londra", "Nero Giza". Mezz-cilindri con apertura bifacciale. Disponibile versione con cilindri girevoli, in posizioni prestabilite, che permettono la chiusura dei vani. Dettagli in ottone satinato.

Sideboard with structure, shelves and half-cylinder in glossy or opaque lacquered wood. Available colours: "Bianco Camargue", "Sabbia del Nilo", "Rosa Jaipur", "Rosso Persia", "Bordeaux Etruria", "Verde Provenza", "Blu Pacifico", "Grigio Londra", "Nero Giza". Half-cylinder with front or rear opening. Available version with rotating cylinders, in pre-established positions, which allows the closing of the compartments. Satin brass details.



## Cm

150 x 50 x 85  
150 x 50 x 125  
150 x 50 x 165  
250 x 50 x 61

## Inches

59¼" x 19¾" x 33½"  
59¼" x 19¾" x 49¼"  
59¼" x 19¾" x 65"  
98½" x 19¾" x 24½"

For technical drawing / p. 423

Pricelist 2023 / p. 252  
Homescapes, intimate portraits / p. 40, 106  
Homescapes, gentle attitude / pp. 73, 75

## STRUTTURA, RIPIANI E MEZZI CILINDRI/STRUCTURE, SHELVES AND HALF-CYLINDER



Legno laccato lucido/opaco  
"Bianco Camargue"  
"Bianco Camargue" glossy/  
opaque lacquered wood



Legno laccato lucido/opaco  
"Sabbia del Nilo"  
"Sabbia del Nilo" glossy/  
opaque lacquered wood

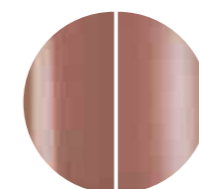

Legno laccato lucido/opaco  
"Bianco Camargue"  
"Bianco Camargue" glossy/  
opaque lacquered wood

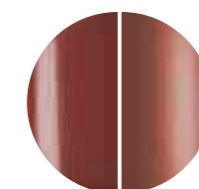

Legno laccato lucido/opaco  
"Rosso Persia"  
"Rosso Persia" glossy/  
opaque lacquered wood

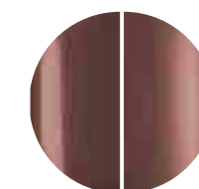

Legno laccato lucido/opaco  
"Bordeaux Etruria"  
"Bordeaux Etruria" glossy/  
opaque lacquered wood

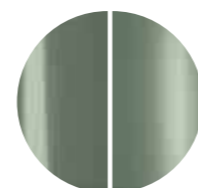

Legno laccato lucido/opaco  
"Verde Provenza"  
"Verde Provenza" glossy/  
opaque lacquered wood

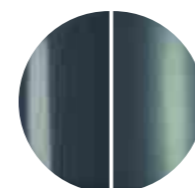

Legno laccato lucido/opaco  
"Blu Pacifico"  
"Blu Pacifico" glossy/  
opaque lacquered wood

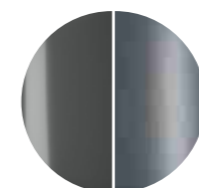

Legno laccato lucido/opaco  
"Grigio Londra"  
"Grigio Londra" glossy/  
opaque lacquered wood



Legno laccato lucido/opaco  
"Nero Giza"  
"Nero Giza" glossy/  
opaque lacquered wood

## DETTAGLI/DETAILS



Ottone satinato  
Satin brass



▲ **HIDE&SEEK**  
Struttura in legno laccato lucido "Rosso Persia"  
"Rosso Persia" glossy lacquered wood structure



▲ **HIDE&SEEK**  
Struttura in legno laccato opaco "Rosso Persia"  
"Rosso Persia" opaque lacquered wood structure



▲ **HIDE&SEEK**  
Struttura in legno laccato lucido "Grigio Londra"  
"Grigio Londra" glossy lacquered wood structure



▲ **HIDE&SEEK**  
Struttura in legno laccato opaco "Grigio Londra"  
"Grigio Londra" opaque lacquered wood structure



▲ **HIDE&SEEK**  
Struttura in legno laccato lucido "Nero Giza"  
"Nero Giza" glossy lacquered wood structure

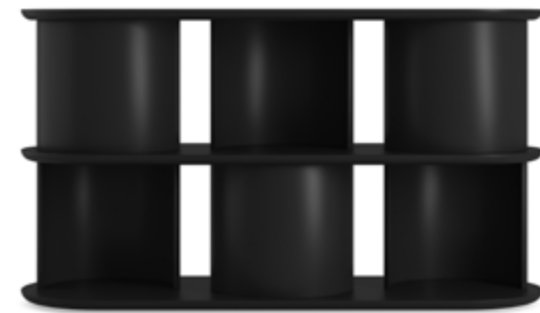

▲ **HIDE&SEEK**  
Struttura in legno laccato opaco "Nero Giza"  
"Nero Giza" opaque lacquered wood structure



▲ **HIDE&SEEK**  
Struttura in legno laccato lucido "Verde Provenza"  
"Verde Provenza" glossy lacquered wood structure



▲ **HIDE&SEEK**  
Struttura in legno laccato lucido "Grigio Londra"  
"Grigio Londra" glossy lacquered wood structure



▲ **HIDE&SEEK DOOR**  
 Struttura in legno laccato lucido "Bordeaux Etruria"/Dettagli ottone satinato  
 "Bordeaux Etruria" glossy lacquered wood structure/Satin brass details

# Hide&Seek Door

Pietro Russo / 2024

Contenitore con struttura, ripiani, ante e mezzo-cilindro girevole in legno laccato lucido o opaco.  
 Colori disponibili: "Bianco Camargue", "Sabbia del Nilo", "Rosa Jaipur", "Rosso Persia", "Bordeaux Etruria", "Verde Provenza", "Blu Pacifico", "Grigio Londra", "Nero Giza".  
 Dettagli in ottone satinato. Contenitore con anta push and pull con ripiano interno in legno laccato nella stessa finitura.  
 Su richiesta versione con apertura anta bifacciale.

Sideboard with structure, shelves, doors and rotating half-cylinder in glossy or opaque lacquered wood. Available colours: "Bianco Camargue", "Sabbia del Nilo", "Rosa Jaipur", "Rosso Persia", "Bordeaux Etruria", "Verde Provenza", "Blu Pacifico", "Grigio Londra", "Nero Giza". Satin brass details.  
 Unit with push and pull door with wooden lacquered shelf in the same finish.  
 On request version with double-sided door opening.



For technical drawing / p. 424

**Cm**  
 200 x 50 x 76  
 250 x 50 x 76

**Inches**  
 78¾" x 19¾" x 30"  
 98½" x 19¾" x 30"

## STRUTTURA, RIPIANI E MEZZI CILINDRI/STRUCTURE, SHELVES AND HALF-CYLINDER



Legno laccato lucido/opaco  
 "Bianco Camargue"  
 "Bianco Camargue" glossy/  
 opaque lacquered wood



Legno laccato lucido/opaco  
 "Sabbia del Nilo"  
 "Sabbia del Nilo" glossy/  
 opaque lacquered wood

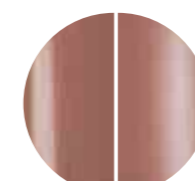

Legno laccato lucido/opaco  
 "Rosso Persia"  
 "Rosso Persia" glossy/  
 opaque lacquered wood

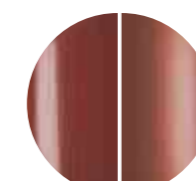

Legno laccato lucido/opaco  
 "Bordeaux Etruria"  
 "Bordeaux Etruria" glossy/  
 opaque lacquered wood

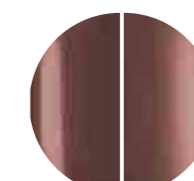

Legno laccato lucido/opaco  
 "Verde Provenza"  
 "Verde Provenza" glossy/  
 opaque lacquered wood

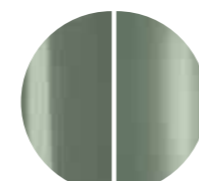

Legno laccato lucido/opaco  
 "Blu Pacifico"  
 "Blu Pacifico" glossy/  
 opaque lacquered wood

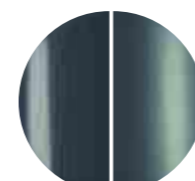

Legno laccato lucido/opaco  
 "Grigio Londra"  
 "Grigio Londra" glossy/  
 opaque lacquered wood

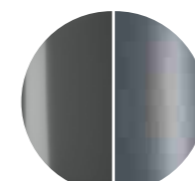

Legno laccato lucido/opaco  
 "Nero Giza"  
 "Nero Giza" glossy/  
 opaque lacquered wood



Ottone satinato  
 Satin brass

## DETTAGLI/DETAILS



Ottone satinato  
 Satin brass



▲ KUMI  
Piano in marmo lucido naturale Verde Alpi  
Natural polished Verde Alpi marble top

# Kumi

Carlo Colombo / 2020

Mobile con struttura in legno tinto nero a poro aperto, rivestita frontalmente e lateralmente con fascia zigrinata a mano.  
Maniglie e parti metalliche in metallo laccato color fango.  
Piano disponibile in marmo 20mm bisellato lucido naturale Calacatta Vagli Oro, Verde Alpi, Arabescato Orobico Rosso satinato, Dover White satinato oppure cristallo temperato 6mm retroverniciato nero brillante.  
Vani con anta dotati di ripiano in legno.

Disponibile nelle seguenti versioni:

Versione h 73,2/74,6 con ante e cassetti.  
Versione h 73,2/74,6 con ante, cassetti e vano a giorno  
Versione h 108,6/110 con ante, cassetti e vano a ribalta con schienale interno specchiato 6mm e dotato di luce interna LED attivata da un sensore all'apertura dell'anta.

#### NOTE TECNICHE SUI MATERIALI

**MARMO** | Il marmo è un materiale naturale di origine sedimentaria che può presentare particolarità come venature, lievi irregolarità superficiali, colorazioni differenti e cristallizzazioni. Queste peculiarità sono da attribuirsi alla naturalezza del materiale e non sono da considerarsi difetti ma caratteristiche tipiche del marmo. Ogni prodotto risulterà unico, esclusivo e non replicabile.  
I nostri marmi vengono trattati con un prodotto idrorepellente che permette una maggiore protezione della superficie stessa, aumentando l'impermeabilità. Questo trattamento non esclude la vulnerabilità del marmo alle sostanze acide.

Sideboard with structure in black stained open pore wood. Front and sides clad with hand knurled border.  
Handles and metal parts lacquered in the "fango" colour.  
Top available in bevelled natural polished Calacatta Vagli Oro, natural polished Verde Alpi, satin Arabescato Orobico Rosso marble, satin Dover White or 6mm thick tempered bright black painted glass.  
Modules with doors supplied with inside wooden shelf.

Available in the following versions:

Version h 73,2/74,6 with doors and drawers.  
Version h 73,2/74,6 with doors, drawers and open module.  
Version h 108,6/110 with side doors, drawers and unit with flap door with 6mm inside mirrored back and supplied with inside LED light turned on by sensor as flap door is opened.

#### TECHNICAL INFORMATION ON THE MATERIALS

**MARBLE** | The marble is a natural material of sedimentary origin that can present particularities such as veins, slight surface irregularities, different colors and crystallizations. These peculiarities are to be attributed to the naturalness of the material and are not to be considered defects but typical characteristics of marble. Each product will be unique, exclusive and non-replicable.  
Our marbles are treated with water-repellent products which affords greater protection to the surface of the marble, improving its impermeability. This treatment doesn't exclude the vulnerability of the marble to acid substances.



#### Cm

**Top cristallo**  
143 x 50 x 73,2  
194 x 50 x 73,2  
143 x 50 x 108,6

#### Top marmo

143 x 50 x 74,6  
194 x 50 x 74,6  
143 x 50 x 110

#### Inches

**Glass top**  
56½" x 19¾" x 29"  
76½" x 19¾" x 29"  
56½" x 19¾" x 43"

#### Marble top

56½" x 19¾" x 29½"  
76½" x 19¾" x 29½"  
56½" x 19¾" x 43½"

For technical drawing / p. 424

Pricelist 2023 / p. 253  
Homescapcs, embracig beauty / p. 22

#### STRUTTURA/STRUCTURE

#### VERSIONE PIANO MARMO/MARBLE TOP VERSION

#### VERSIONE PIANO CRISTALLO/ GLASS TOP VERSION



**Legno tinto nero poro aperto**  
Black open pore stained wood



**Marmo lucido naturale Calacatta Vagli Oro**  
Natural polished Calacatta Vagli Oro marble



**Marmo lucido naturale Verde Alpi**  
Natural polished Verde Alpi marble



**Marmo Arabescato Orobico Rosso satinato**  
Arabescato Orobico Rosso satin marble

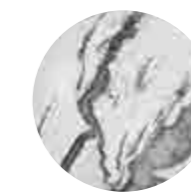

**Marmo satinato Dover white**  
Satin Dover white marble

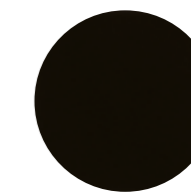

**Cristallo retroverniciato nero brillante**  
Bright black painted glass

#### VERSIONE H.110/ H.110 VERSION

#### SCHIENALE INTERNO/ INSIDE BACK



**Specchio**  
Mirror

#### LUCE INTERNA/ INSIDE LIGHT

LED 15W  
108 lm  
3000K  
Cable lenght: 1,5mt

#### PARTI METALLICHE/ METAL PARS

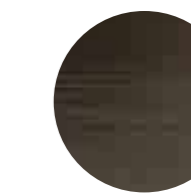

**Metallo laccato "fango"**  
Metal lacquered "fango"



▲ **PANDORA**  
 Esterno in foglia oro ossidata / Interno in foglia oro con ripiano in cristallo extralight  
 Oxidated gold leaf outside / Gold leaf inside with 8mm extralight glass shelves

# Pandora

Pinuccio Borgonovo / 2014

Madia in cristallo 8mm extralight temperato, rivestito in foglia oro applicata con lavorazione manuale ed esclusiva. Grazie a questo trattamento, il contenitore assume una colorazione disomogenea e unica all'esterno e mantiene la finitura dorata all'interno. Dotata di ripiani in cristallo 8mm extralight temperato. Struttura e maniglie in metallo verniciate bronzo patinato. Piani in legno rivestiti in foglia oro. Collezione in edizione numerata.

Sideboard in 8mm extralight tempered glass covered by gold leaf applied by hand with an exclusive treatment. Thanks to this process the unit has an irregular and unique finish outside and a gold finish inside. Supplied with 8mm extralight tempered glass shelves. Patinated bronze lacquered metal structure and handles. Wooden tops covered by gold leaf. Collection in numbered edition.

## NOTE TECNICHE SUI MATERIALI

**FINITURE ARTIGIANALI** | Le finiture manuali ed esclusive, risultato del processo di ossidazione di foglia argento, oro e rame, possono presentare macchie e striature, oltre a differenze cromatiche. Tali disomogeneità sono caratteristiche che non devono essere considerate difetti ma elementi distintivi, tipici dell'ossidazione manuale, che esaltano la bellezza e la peculiarità del pezzo unico.

## TECHNICAL INFORMATION ON THE MATERIALS

**ARTISANAL FINISHES** | Artisanal and exclusive finishes that are obtained from the oxidation of silver, gold and copper leaves may show marks and spots, as well as variations in colour. These differences are inevitable and should not be considered imperfections but evidence of the hand-crafted process. They enhance the beauty and distinctiveness of a unique piece.



### Cm

162 x 52 x 71  
 162 x 52 x 100  
 162 x 52 x 126  
 202 x 52 x 71

### Inches

64" x 20½" x 28"  
 64" x 20½" x 39½"  
 64" x 20½" x 49¾"  
 79¾" x 20½" x 28"

[For technical drawing / p. 425](#)

[Pricelist 2023 / p. 254](#)  
[Homescapes, gentle attitude / pp. 28, 29](#)

## STRUTTURA/STRUCTURE



Esterno - foglia oro ossidata  
 Interno - foglia oro  
 Outside - oxidated gold leaf  
 Inside - gold leaf

## BASE E MANIGLIE/BASE AND HANDLES



Metallo verniciato  
 bronzo patinato  
 Lacquered bronze  
 patinated

## RIPIANI/SHELVES



Cristallo extralight  
 Extralight glass



# Pandora Cashmere

Pinuccio Borgonovo / 2020

Madia in cristallo 8mm extralight temperato, verniciato nella finitura esclusiva spazzolata "Cashmere" nei colori gold grey o anthracite. Interno retroverniciato nero brillante. Dotata di ripiani in cristallo 8mm extralight temperato. Struttura e maniglie in metallo e base in legno, verniciati bronzo patinato. Collezione in edizione numerata.

Sideboard in 8mm tempered extralight glass painted with the exclusive "Cashmere" brushed finish in the colours gold grey or anthracite. Bright black painted inside. Supplied with 8mm extralight tempered glass shelves. Patinated bronze lacquered metal structure, handles and wooden base. Collection in numbered edition.

## NOTE TECNICHE SUI MATERIALI

**CRISTALLO** | Le finiture esclusive, risultato della lavorazione manuale realizzata sul cristallo, possono presentare striature e differenze cromatiche. Queste caratteristiche non devono essere considerate difetti ma elementi distintivi del processo artigianale che esaltano la bellezza e la peculiarità del pezzo unico.

## TECHNICAL INFORMATION ON THE MATERIALS

**GLASS** | Exclusive finishes, resulting from the craftsmanship on the glass, may show streaks and chromatic differences. These characteristics should not be considered imperfections but distinctive evidence of the hand-made process that enhance the beauty and peculiarity of the unique piece.



## Cm

162 x 52 x 71  
162 x 52 x 100  
162 x 52 x 126  
202 x 52 x 71

## Inches

64" x 20½" x 28"  
64" x 20½" x 39½"  
64" x 20½" x 49¾"  
79¾" x 20½" x 28"

For technical drawing / p. 425

Pricelist 2023 / p. 255  
Homescapes, intimate portraits/ p. 78, 81

## STRUTTURA/STRUCTURE

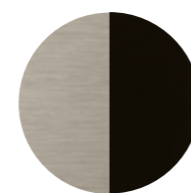

Esterno- cristallo  
"Cashmere" gold grey/  
Interno- cristallo nero  
brillante  
Outside- "Cashmere" gold  
grey glass/  
Inside-Bright black glass



Esterno- cristallo  
"Cashmere" anthracite/  
Interno- cristallo nero  
brillante  
Outside- "Cashmere"  
anthracite glass/  
Inside-Bright black glass

## BASE E MANIGLIE/ BASE AND HANDLES



Metallo verniciato  
bronzo patinato  
Patinated bronze  
lacquered

## RIPIANI/SHELVES



Cristallo extralight  
Extralight glass

# Pandora Craquelé

Pinuccio Borgonovo / 2016

Madia in cristallo 8mm extralight temperato, decorato con lavorazione manuale ed esclusiva. Dotata di ripiani in cristallo 8mm extralight temperato. Struttura e maniglie in metallo e base in legno, verniciati bronzo patinato. Collezione in edizione numerata.

Sideboard in 8mm tempered extralight glass decorated by hand with exclusive treatment. Supplied with 8mm extralight tempered glass shelves. Patinated bronze lacquered metal structure, handles and wooden base. Collection in numbered edition.

## NOTE TECNICHE SUI MATERIALI

**CRISTALLO** | Le finiture esclusive, risultato della lavorazione manuale realizzata sul cristallo, possono presentare striature e differenze cromatiche. Queste caratteristiche non devono essere considerate difetti ma elementi distintivi del processo artigianale che esaltano la bellezza e la peculiarità del pezzo unico.

## TECHNICAL INFORMATION ON THE MATERIALS

**GLASS** | Exclusive finishes, resulting from the craftsmanship on the glass, may show streaks and chromatic differences. These characteristics should not be considered imperfections but distinctive evidence of the hand-made process that enhance the beauty and peculiarity of the unique piece.



### Cm

162 x 52 x 71  
162 x 52 x 100  
162 x 52 x 126  
202 x 52 x 71

### Inches

64" x 20½" x 28"  
64" x 20½" x 39½"  
64" x 20½" x 49¾"  
79¾" x 20½" x 28"

For technical drawing / p. 425

Pricelist 2023 / p. 256

### BASE E MANIGLIE BASE AND HANDLES



Cristallo Craquelé  
Craquelé glass



Metallo verniciato  
bronzo patinato  
Patinated bronze  
lacquered

### RIPIANI/SHELVES



Cristallo extralight  
Extralight glass





▲ PANDORA LIGHT  
 Dettaglio piano inferiore in marmo spazzolato Emperador Brown  
 Brushed Emperador Brown marble bottom shelf detail

# Pandora Light

Pinuccio Borgonovo / 2016

Madia in cristallo 8mm extralight temperato con top in cristallo 8mm verniciato bronzo patinato. Dotata di ripiani in cristallo 8mm extralight temperato. Struttura e maniglie in metallo verniciate bronzo patinato. Piano inferiore in legno rivestito in foglia oro oppure in marmo Emperador Brown spazzolato. Disponibile versione con schienale in cristallo e piano inferiore in legno verniciati bronzo patinato. Collezione in edizione numerata.

Sideboard in 8mm extralight tempered glass with 8mm patinated bronze painted glass top. Supplied with 8mm extralight tempered glass shelves. Patinated bronze lacquered metal structure and handles. Wooden bottom shelf covered by gold leaf or brushed Emperador Brown marble. Also available version with patinated bronze lacquered glass back and wooden bottom shelf. Collection in numbered edition.

## NOTE TECNICHE SUI MATERIALI

**CRISTALLO** | Le finiture esclusive, risultato della lavorazione manuale realizzata sul cristallo, possono presentare striature e differenze cromatiche. Queste caratteristiche non devono essere considerate difetti ma elementi distintivi del processo artigianale che esaltano la bellezza e la peculiarità del pezzo unico.

**MARMO** | Il marmo è un materiale naturale di origine sedimentaria che può presentare particolarità come venature, lievi irregolarità superficiali, colorazioni differenti e cristallizzazioni. Queste peculiarità sono da attribuirsi alla naturalezza del materiale e non sono da considerarsi difetti ma caratteristiche tipiche del marmo. Ogni prodotto risulterà unico, esclusivo e non replicabile.

## TECHNICAL INFORMATION ON THE MATERIALS

**GLASS** | Exclusive finishes, resulting from the craftsmanship on the glass, may show streaks and chromatic differences. These characteristics should not be considered imperfections but distinctive evidence of the hand-made process that enhance the beauty and peculiarity of the unique piece.

**MARBLE** | The marble is a natural material of sedimentary origin that can present particularities such as veins, slight surface irregularities, different colors and crystallizations. These peculiarities are to be attributed to the naturalness of the material and are not to be considered defects but typical characteristics of marble. Each product will be unique, exclusive and non-replicable.



### Cm

162 x 52 x 71  
 162 x 52 x 100  
 162 x 52 x 126  
 202 x 52 x 71

### Inches

64" x 20½" x 28"  
 64" x 20½" x 39½"  
 64" x 20½" x 49¾"  
 79¾" x 20½" x 28"

For technical drawing / p. 426

Pricelist 2023 / p. 257  
 Homescapes, sense of materials / p. 32

STRUTTURA/STRUCTURE	TOP	MANIGLIE E PARTI METALLICHE/HANDLES AND METAL PARTS	RIPIANI E SCHIENALE/ SHELVES AND BACK	PIANO INFERIORE/BOTTOM SHELF	
Cristallo extralight Extralight glass	Cristallo verniciato bronzo patinato Patinated bronze painted glass	Metallo verniciato bronzo patinato Patinated bronze lacquered metal	Cristallo extralight Extralight glass	Legno rivestito foglia oro Gold leaf wood covered	Marmo spazzolato Emperador Brown Brushed Emperador Brown marble
NEW VERSION 2022 STRUTTURA/STRUCTURE	TOP E SCHIENALE/ TOP AND BACK	MANIGLIE E PARTI METALLICHE/HANDLES AND METAL PARTS	RIPIANI/SHELVES	PIANO INFERIORE/ BOTTOM SHELF	
Cristallo extralight Extralight glass	Cristallo verniciato bronzo patinato Patinated bronze painted glass	Metallo verniciato bronzo patinato Patinated bronze lacquered metal	Cristallo extralight Extralight glass	Legno verniciato bronzo patinato Patinated bronze lacquered wood	



## ▲ SODA

Struttura in legno frassino tinto nero poro aperto e anta in cristallo fuso temperato "grigio Italia".  
 Schienale e ripiani in cristallo "grigio Italia" / dettagli ottone satinato  
 Black open pore stained ash structure and molten tempered glass "grigio Italia" door/  
 Back and shelves tempered smoked "grigio Italia" glass/satin brass details.

# Soda

Draga & Aurel / 2022

Vetrina con struttura in legno laccato color "elephant grey" e anta in cristallo fuso 6mm temperato verniciato color ambra.

Disponibile versione con struttura in legno frassino tinto nero a poro aperto e anta in cristallo fuso 6mm temperato "grigio Italia". Entrambe con schienale e ripiani in cristallo "grigio Italia" 6mm temperato. Dettagli in ottone satinato.

Disponibile versione con struttura in legno laccato opaco color "Sabbia del Nilo" e anta in cristallo fuso 6mm temperato verniciato color ametista. Disponibile anche con anta in cristallo fuso 6mm temperato extralight. Schienale e ripiani in cristallo extralight 6mm temperato. A richiesta schienale in cristallo fuso 6mm temperato verniciato color ametista. Dettagli in bronzo patinato.

Sideboard with "elephant grey" lacquered wooden structure and 6mm molten tempered glass amber color lacquered door.

Also available version with black open pore stained ash structure and 6mm molten tempered glass "grigio Italia" door. Both version with back and shelves in 6mm tempered smoked "grigio Italia" glass. Details in satin brass.













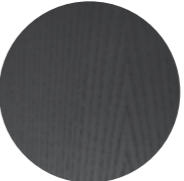



Available also new version with "Sabbia del Nilo" opaque lacquered wooden structure and 6mm molten tempered amethyst color lacquered glass door. Available also with 6mm molten tempered extralight glass door. Back and shelves in 6mm tempered extralight glass. On request 6mm molten tempered amethyst color lacquered glass back. Patinated bronze metal details.

For technical drawing / p. 426

Pricelist 2023 / p. 258  
 Homescapes, gentle attitude / pp. 48, 92, 93, 96, 97

Cm  
 120 x 46 x 165

Inches  
 47¼" x 18¼" x 65"

STRUTTURA/STRUCTURE	ANTE/DOOR	STRUTTURA/STRUCTURE	ANTE/DOOR	
				
Legno laccato "elephant grey" "Elephant grey" lacquered wood	Cristallo fuso temperato verniciato ambra Molten tempered glass lacquered amber color	Frassino tinto nero a poro aperto Black open pore stained ash	Cristallo fuso temperato "grigio Italia" Molten tempered glass "grigio Italia"	
SCHIENALE E RIPIANI BACK AND SHELVES	DETTAGLI/DETAILS	SCHIENALE E RIPIANI BACK AND SHELVES	DETTAGLI/DETAILS	
				
Cristallo "grigio Italia" "Grigio Italia" glass	Ottone satinato Satin brass	Cristallo "grigio Italia" "Grigio Italia" glass	Ottone satinato Satin brass	
STRUTTURA/STRUCTURE	ANTE/DOOR	STRUTTURA/STRUCTURE	ANTE/DOOR	
				
Laccato opaco "Sabbia del Nilo" Opaque lacquered "Sabbia del Nilo"	Cristallo fuso temperato verniciato ametista Molten tempered glass lacquered amethyst color	Cristallo fuso temperato "extralight" Molten tempered glass "extralight"	Cristallo fuso temperato verniciato ametista Molten tempered glass lacquered amethyst color	
SCHIENALE E RIPIANI BACK AND SHELVES	DETTAGLI/DETAILS	SCHIENALE/BACK	RIPIANI/SHELVES	DETTAGLI/DETAILS
				
Cristallo extralight Extralight glass	Bronzo patinato Patinated bronze	Cristallo fuso temperato verniciato ametista Molten tempered glass lacquered amethyst color	Cristallo extralight Extralight glass	Bronzo patinato Patinated bronze



▲ SODA  
Struttura in legno laccato color "elephant grey" e ante cristallo fuso temperato verniciato color ambra/Schienale e ripiani in cristallo "grigio Italia"/dettagli ottone satinato  
"Elephant grey" lacquered wooden structure and molten tempered glass amber color lacquered door/ back and shelves in smoked "grigio Italia" glass/satin brass details



▲ SODA  
Struttura in legno frassino tinto nero a poro aperto e ante in cristallo fuso temperato "grigio Italia"/Schienale e ripiani in cristallo "grigio Italia" / dettagli ottone satinato  
Black open pore stained ash structure and molten tempered glass "grigio Italia" door/ Back and shelves tempered smoked "grigio Italia" glass/satin brass details.



▲ SODA  
Struttura in legno laccato opaco color "Sabbia del Nilo" e ante cristallo fuso temperato verniciato color ametista/Schienale e ripiani in cristallo extralight/ dettagli bronzo patinato  
"Sabbia del Nilo" opaque lacquered wooden structure and molten tempered glass amethyst color lacquered door/ back and shelves in "extralight" glass/patinated bronze details



▲ SODA  
Struttura in legno laccato opaco color "Sabbia del Nilo" e ante cristallo fuso temperato verniciato color ametista/Schienale cristallo fuso temperato verniciato color ametista e ripiani in cristallo extralight/dettagli bronzo patinato  
"Sabbia del Nilo" opaque lacquered wooden structure and molten tempered glass amethyst color lacquered door/ molten tempered amethyst color lacquered glass back and shelves in "extralight" glass/patinated bronze details



▲ SODA  
Struttura in legno laccato opaco color "Sabbia del Nilo" e ante cristallo fuso temperato verniciato color ametista/Schienale e ripiani in cristallo extralight/ dettagli bronzo patinato  
"Sabbia del Nilo" opaque lacquered wooden structure and molten tempered glass amethyst color lacquered door/ back and shelves in "extralight" glass/patinated bronze details



▲ STAMI SIDEBOARD  
 Contenitore rivestito in Fard loden green 2357  
 Unit covered in Fard loden green 2357

# Stami Sideboard

Studiopepe / 2024

Madia con base in frassino curvato tinto nero a poro aperto e dettagli in ottone lucido. Contenitore in legno rivestito in pelle fard nei colori del campionario. Dotata di ripiano interno in cristallo extralight 8mm temperato.

Sideboard with curved black open pore stained ash base and bright brass details. Wooden unit covered by leather fard as per samples. Supplied with 8mm extralight inside glass shelf.



**Cm**  
 179 x 50 x 75  
 233 x 50 x 75

**Inches**  
 70½" x 19¾" x 29¾"  
 91¾" x 19¾" x 29¾"

[For technical drawing / p. 426](#)

[Pricelist 2023 / p. 256](#)

**BASE/BASE**

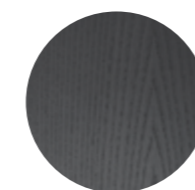

Frassino tinto nero a poro aperto  
 Black open pore stained ash

**CONTENITORE/UNIT**



Legno rivestito in pelle fard nei colori del campionario  
 Wood covered leather fard as per samples

**DETTAGLI/DETAILS**



Ottone lucido  
 Bright brass



# Tama

Carlo Colombo / 2015

Mobile bar in frassino tinto nero a poro aperto con parti metalliche laccato ottone satinato. Interno rivestito in specchio 5mm "grigio Italia" inciso. Ripiano interno in cristallo "grigio Italia" 8mm temperato. Dotata di luce interna LED attivata da un sensore all'apertura delle ante.

Black open pore stained ash wooden bar unit and satin brass lacquered metal parts. Inside covered by 5mm engraved smoked "grigio Italia" mirror. Supplied with 8mm tempered smoked "grigio Italia" glass shelf. Supplied with inside LED light turned on by sensor as doors are opened.



**Cm**  
70 x 40 x 141,5

**Inches**  
27¾" x 15¾" x 55¾"

[For technical drawing / p. 427](#)

[Pricelist 2023 / p. 259](#)

## STRUTTURA/STRUCTURE

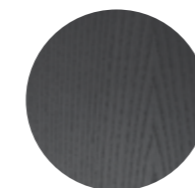

**Frassino tinto nero a poro aperto**  
Black open pore stained ash

## PARTI METALLICHE/METAL PARTS



**Ottone satinato**  
Satin brass

## INTERNO/INSIDE

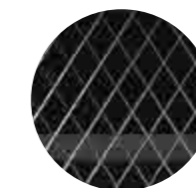

**Specchio "grigio Italia" con incisione a rombi**  
Smoked "grigio Italia" mirror with rhomboidal engraved pattern

## RIPIANO INTERNO/INSIDE SHELF



**Cristallo "grigio Italia"**  
"Grigio Italia" glass

## LUCE INTERNA/INSIDE LIGHT

LED 15W  
108 lm  
3000K  
Cable length: 1,5mt

# Tama Crédence

Carlo Colombo / 2016

Madia in frassino tinto nero a poro aperto con parti metalliche laccate ottone satinato. Top in cristallo temperato 6mm e schienale interno in cristallo 6mm entrambi retroverniciati liquirizia brillante. Sullo schienale interno incisione a rombi. Ripiani interni in cristallo "grigio Italia" 8mm temperato e vassoi portaoggetti in legno. Dotata di luce interna LED attivata da un sensore all'apertura delle ante.

Sideboard in black open pore stained ash with satin brass lacquered metal parts. 6mm tempered glass top and 6mm inside back both bright liquorice painted. Rhomboidal engraved pattern on the inside glass back. Supplied with 8mm tempered smoked "grigio Italia" glass shelf and wooden trays. Supplied with inside LED light turned on by sensor as doors are opened.



**Cm**  
240 x 48 x 72

**Inches**  
94½" x 19" x 28½"

[For technical drawing / p. 427](#)

[Pricelist 2023 / p. 260](#)  
[Homescapes, gentle attitude / pp. 86, 87](#)

**STRUTTURA/STRUCTURE**

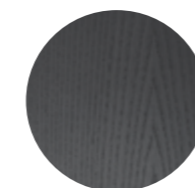

Frassino tinto  
nero a poro aperto  
Black open pore  
stained ash

**PARTI METALLICHE/  
METAL PARTS**



Ottone satinato  
Satin brass

**PIANO/TOP**

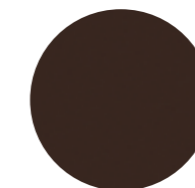

Cristallo retroverniciato  
liquirizia brillante  
Bright liquorice  
painted glass

**SCHIENALE INTERNO/  
INSIDE BACK**



Cristallo retroverniciato  
liquirizia brillante con  
incisione a rombi  
Bright liquorice painted  
glass with rhomboidal  
engraved pattern

**RIPIANO INTERNO/  
INSIDE SHELF**



Cristallo "grigio Italia"  
"Grigio Italia" glass

**LUCE INTERNA/  
INSIDE LIGHT**

LED 15W  
108 lm  
3000K  
Cable length: 1,5mt



# Tama Vitrine

Carlo Colombo / 2020

Madia in frassino tinto nero a poro aperto. Parti metalliche laccate ottone satinato. Top in cristallo temperato 6mm e schienale interno in cristallo 6mm entrambi retroverniciati liquirizia brillante. Sullo schienale interno incisione a rombi. Dotata di ripiani in cristallo "grigio Italia" 8mm. Anta centrale in cristallo 4mm e alluminio color bronzo. Dotata di luce interna LED attivata da un sensore all'apertura delle ante.

## NOTE TECNICHE SUI MATERIALI

**CRISTALLO** | Le finiture esclusive, risultato della lavorazione manuale realizzata sul cristallo, possono presentare striature e differenze cromatiche. Queste caratteristiche non devono essere considerate difetti ma elementi distintivi del processo artigianale che esaltano la bellezza e la peculiarità del pezzo unico.

Sideboard in black open pore stained ash. Satin brass lacquered metal parts. 6mm tempered glass top and 6mm inside back both bright liquorice painted. Rhomboidal engraved pattern on the inside glass back. Supplied with 8mm tempered smoked "grigio Italia" glass shelves. Central door in 4mm glass and aluminium in the colour bronze. Supplied with inside LED light turned on by sensor as doors are opened.

## TECHNICAL INFORMATION ON THE MATERIALS

**GLASS** | Exclusive finishes, resulting from the craftsmanship on the glass, may show streaks and chromatic differences. These characteristics should not be considered imperfections but distinctive evidence of the hand-made process that enhance the beauty and peculiarity of the unique piece.



**Cm**  
125 x 49 x 131

**Inches**  
49¼" x 19½" x 51¾"

For technical drawing / p. 427

Pricelist 2023 / p. 261

## STRUTTURA/STRUCTURE

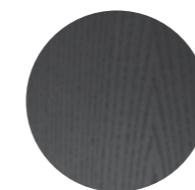

Frassino tinto  
nero a poro aperto  
Black open pore  
stained ash

## LUCE INTERNA/ INSIDE LIGHT

LED 15W  
108 lm  
3000K  
Cable length: 1,5mt

## PARTI METALLICHE/ METAL PARTS



Ottone satinato  
Satin brass

## ANTA CENTRALE/ CENTRAL DOOR

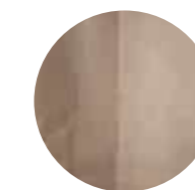

Cristallo/Alluminio  
color bronzo  
Glass/Aluminium  
colour bronze

## PIANO/TOP

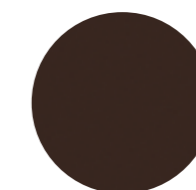

Cristallo retroverniciato  
liquirizia brillante  
Bright liquorice  
painted glass

## SCHIENALE INTERNO/ INSIDE BACK



Cristallo retroverniciato  
liquirizia brillante con  
incisione a rombi  
Bright liquorice painted  
glass with rhomboidal  
engraved pattern

## RIPIANO INTERNO/ INSIDE SHELF



Cristallo "grigio Italia"  
"Grigio Italia" glass

**08**

**Contenitori / Storage Units**  
**TECHNICAL MODULE**



**5th Avenue** | Marcello Pozzi, 2019

Product information / p. 372

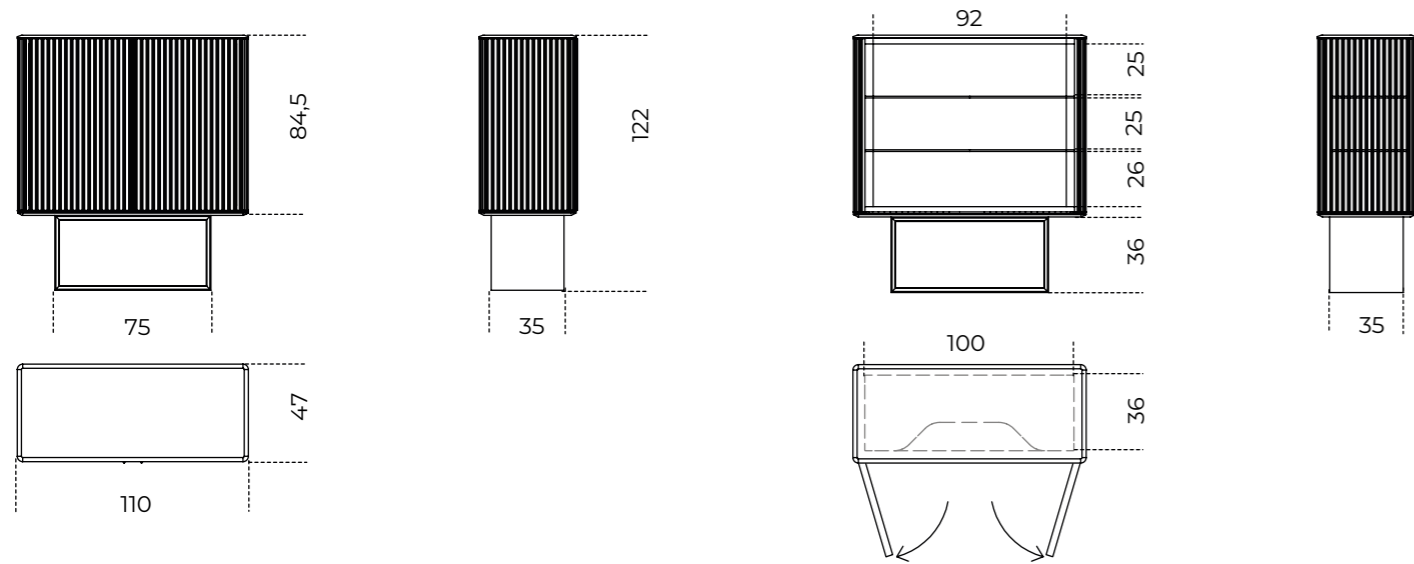

**Athus** | Oscar e Gabriele Buratti, 2017

Product information / p. 376

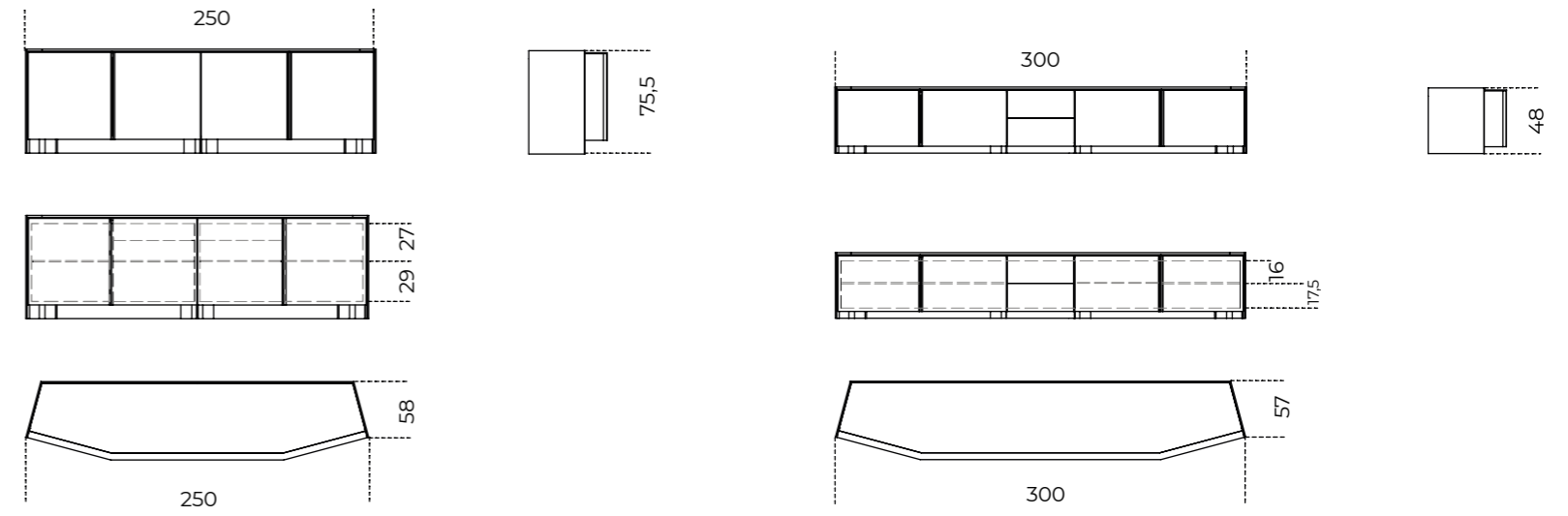

**5th Avenue Crédence** | Marcello Pozzi, 2020

Product information / p. 374

**Versione 2 moduli A**  
Version with 2 modules A

**Versione 3 moduli A**  
Version with 3 modules A

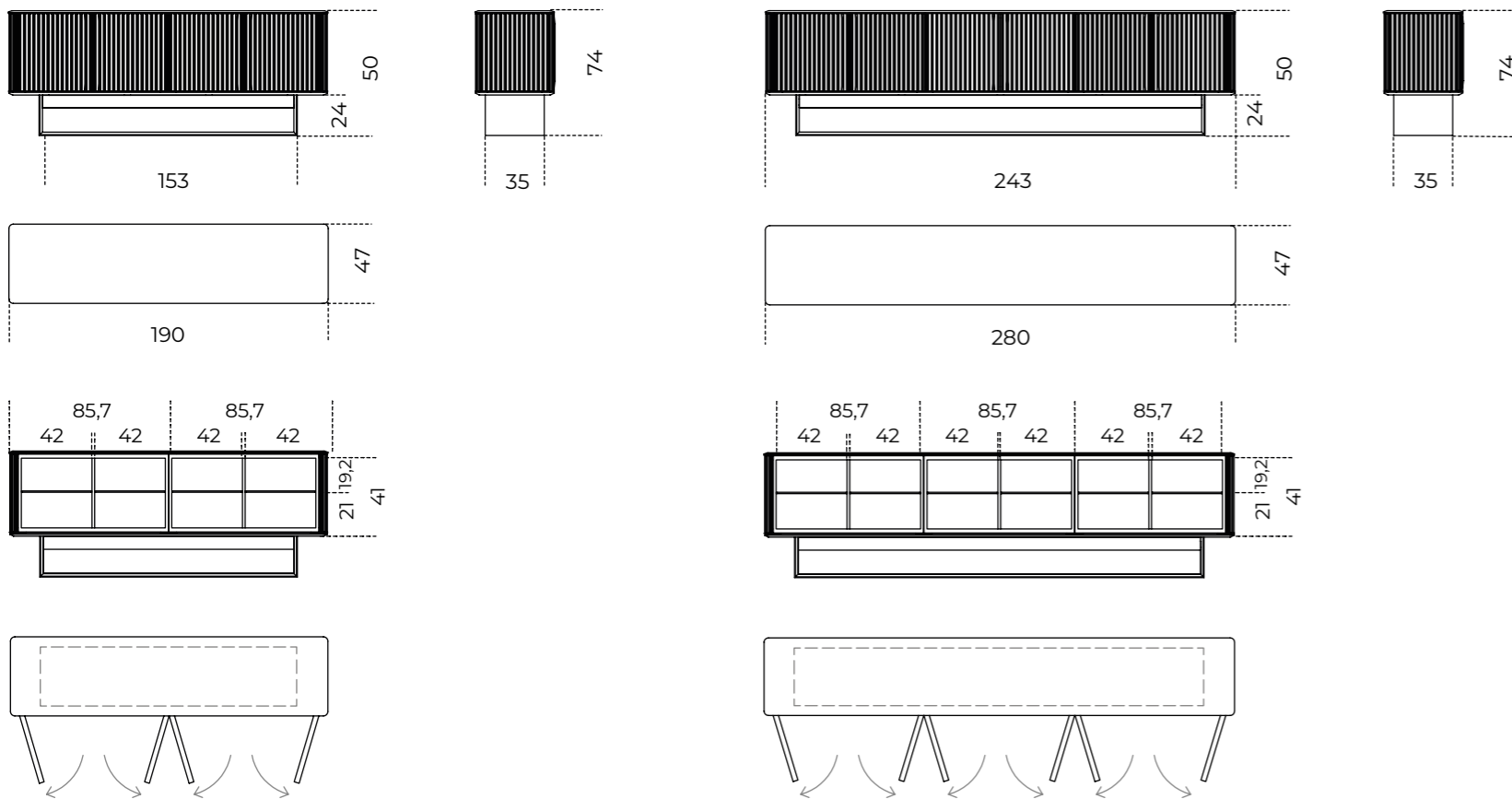

**Vano versione A / Version A**

n.2 ripiani in cristallo extralight  
n. 2 extralight glass shelves

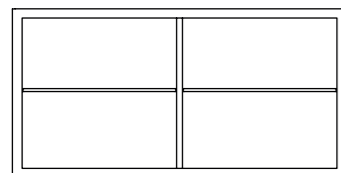

**Vano versione B / Version B**

n.2 ripiani in cristallo extralight +  
n.1 vano centrale  
n. 2 extralight glass shelves +  
n. 1 central compartment

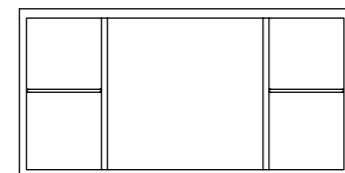

**Vano versione C / Version C**

n.4 ripiani in cristallo extralight +  
n.4 vassoi in frassino tinto nero poro aperto  
n. 4 extralight glass shelves +  
n. 4 black open pore stained ash wooden tray

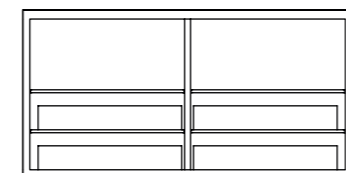

**Diedro** | Pietro Russo, 2022

Product information / p. 378

**Versione freestanding / Freestanding version**

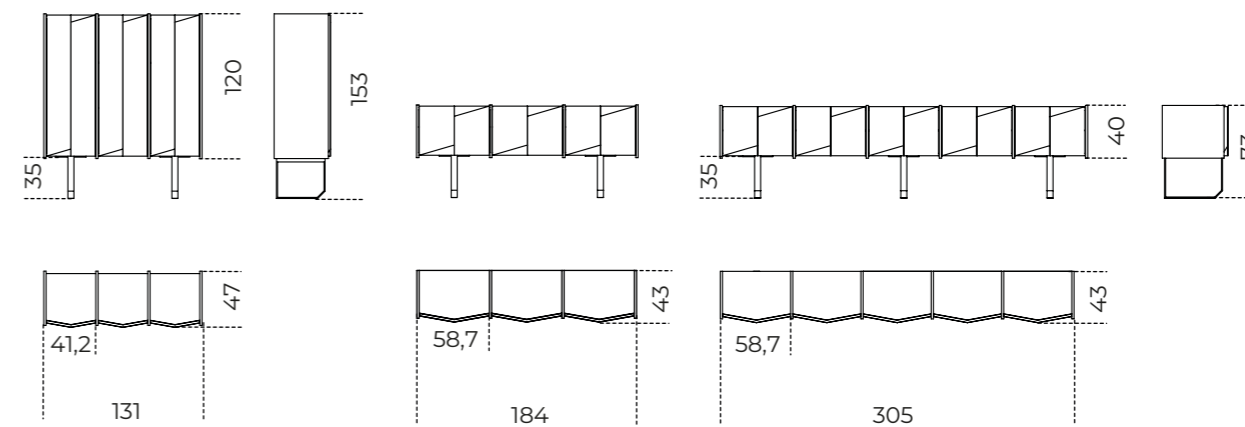

**Versione pensile / Suspended version**

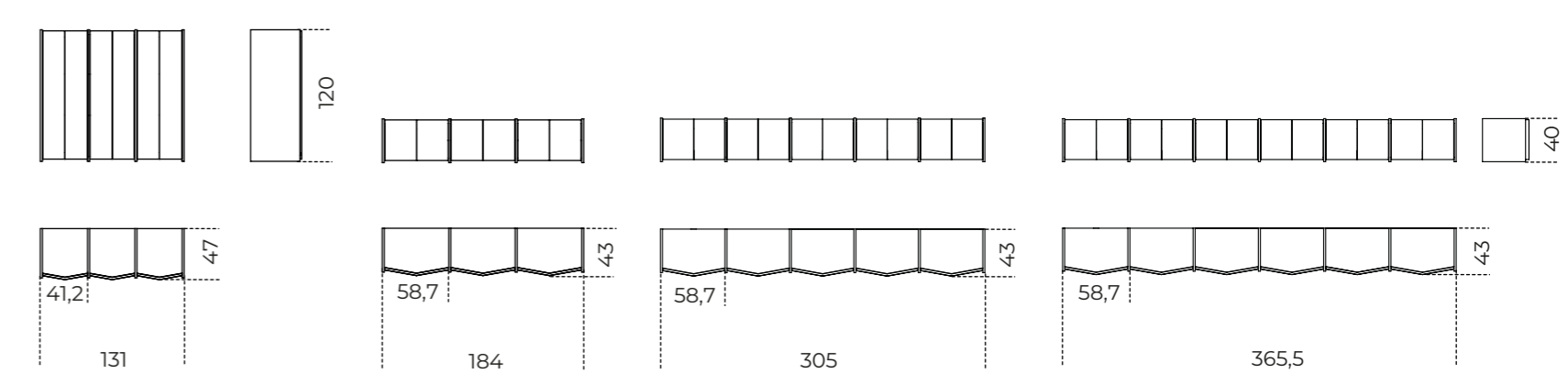

**Gastone** | Carlo Colombo, 2023

Product information / p. 382

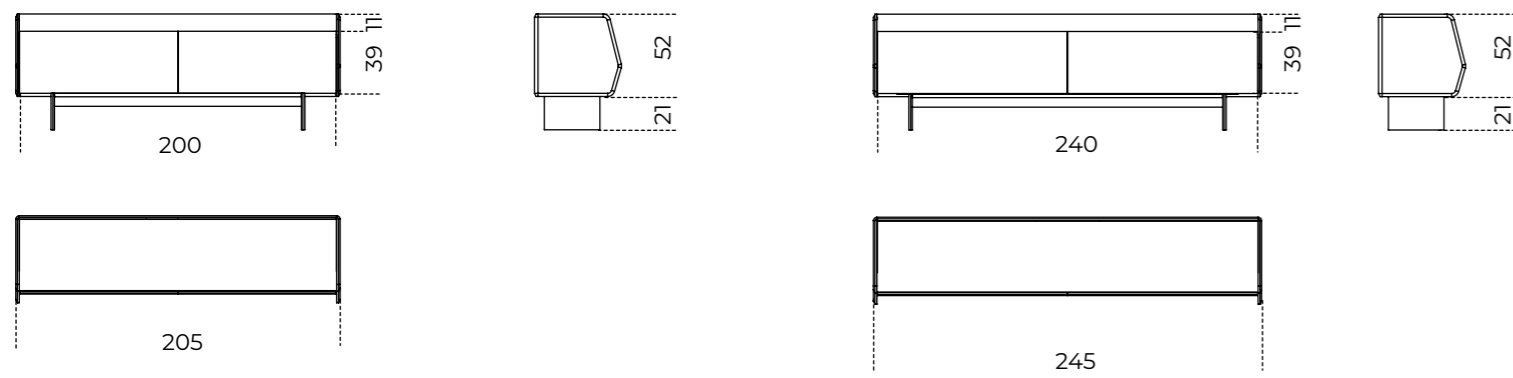

**Versione AA (ante)**  
Version AA (doors)

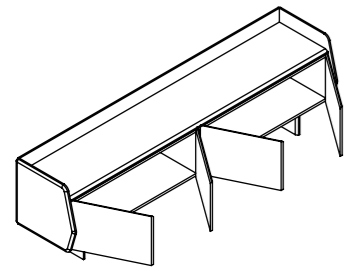

**Cm**  
205 x 55 x 73,5h  
245 x 55 x 73,5h

**Inches**  
80 3/4" x 21 3/4" x 29"  
96 1/2" x 21 3/4" x 29"

**Ripiano interno in cristallo extralight**  
Inside extralight glass shelf

**Cm**  
100  
120

**Inches**  
39 1/2"  
47 1/4"

**Versione CC (cassettoni)**  
Version CC (large drawers)

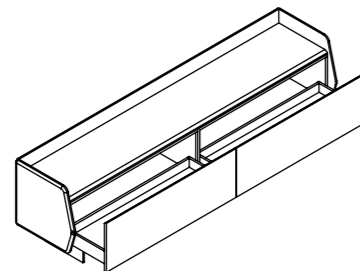

**Cm**  
205 x 55 x 73,5h  
245 x 55 x 73,5h

**Inches**  
80 3/4" x 21 3/4" x 29"  
96 1/2" x 21 3/4" x 29"

**Cassetto interno**  
Inside drawer

**Cm**  
100  
120

**Inches**  
39 1/2"  
47 1/4"

**Versione RR (ribalte)**  
Version RR (flap doors)

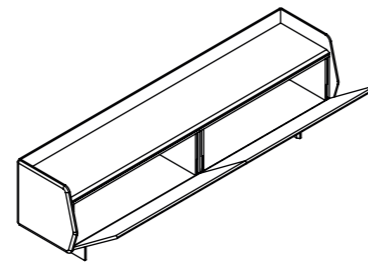

**Cm**  
205 x 55 x 73,5h  
245 x 55 x 73,5h

**Inches**  
80 3/4" x 21 3/4" x 29"  
96 1/2" x 21 3/4" x 29"

**Versione AC (ante/cassettone)**  
Version AC (doors/large drawer)

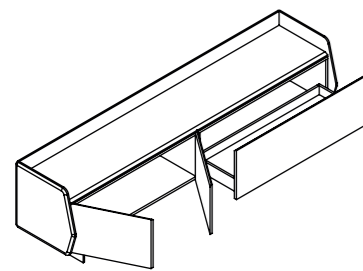

**Cm**  
205 x 55 x 73,5h  
245 x 55 x 73,5h

**Inches**  
80 3/4" x 21 3/4" x 29"  
96 1/2" x 21 3/4" x 29"

**Ripiano interno in cristallo extralight**  
Inside extralight glass shelf

**Cassetto interno**  
Inside drawer

**Cm**  
100  
120

**Inches**  
39 1/2"  
47 1/4"

**Versione AR (ante/ribalta)**  
Version AR (doors/flap door)

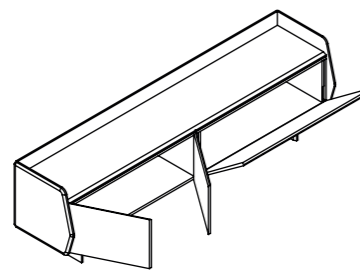

**Cm**  
205 x 55 x 73,5h  
245 x 55 x 73,5h

**Inches**  
80 3/4" x 21 3/4" x 29"  
96 1/2" x 21 3/4" x 29"

**Ripiano interno in cristallo extralight**  
Inside extralight glass shelf

**Cm**  
100  
120

**Inches**  
39 1/2"  
47 1/4"

**Versione RC (ribalta/cassettone)**  
Version RC (flap door/large drawer)

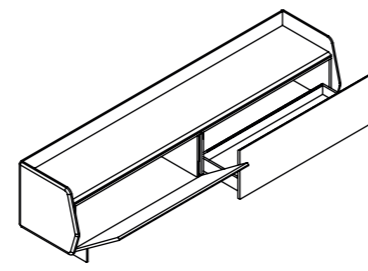

**Cm**  
205 x 55 x 73,5h  
245 x 55 x 73,5h

**Inches**  
80 3/4" x 21 3/4" x 29"  
96 1/2" x 21 3/4" x 29"

**Cassetto interno**  
Inside drawer

**Cm**  
100  
120

**Inches**  
39 1/2"  
47 1/4"

**Top in marmo (opzionale)**  
Marble top (optional)

**Cm**  
200  
240

**Inches**  
78 3/4"  
94 1/2"

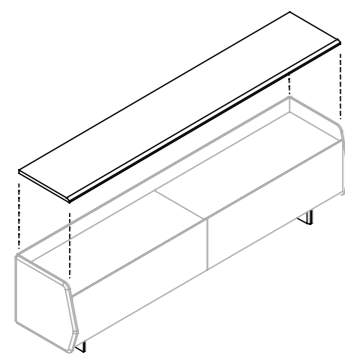

**Mensola superiore sagomata in cristallo (opzionale)**  
Shaped upper glass shelf (optional)

**Cm**  
200  
240

**Inches**  
78 3/4"  
94 1/2"

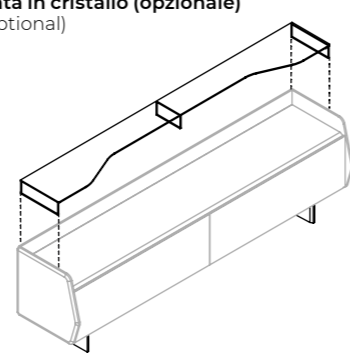

**Gastone Low** | Carlo Colombo, 2023

Product information / p. 384

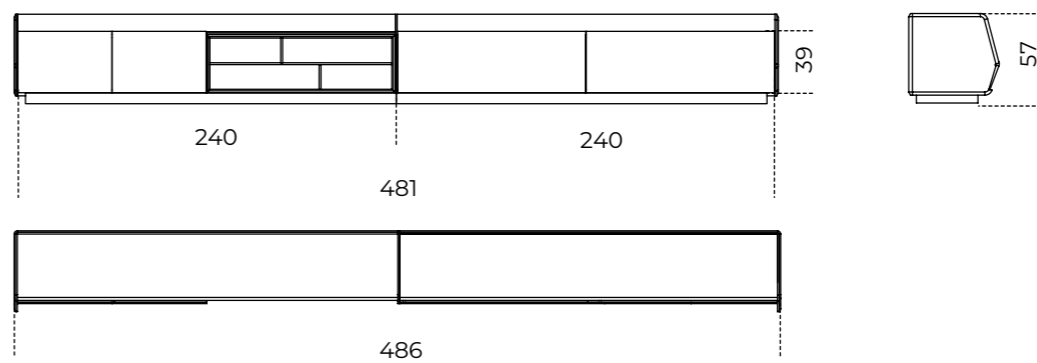
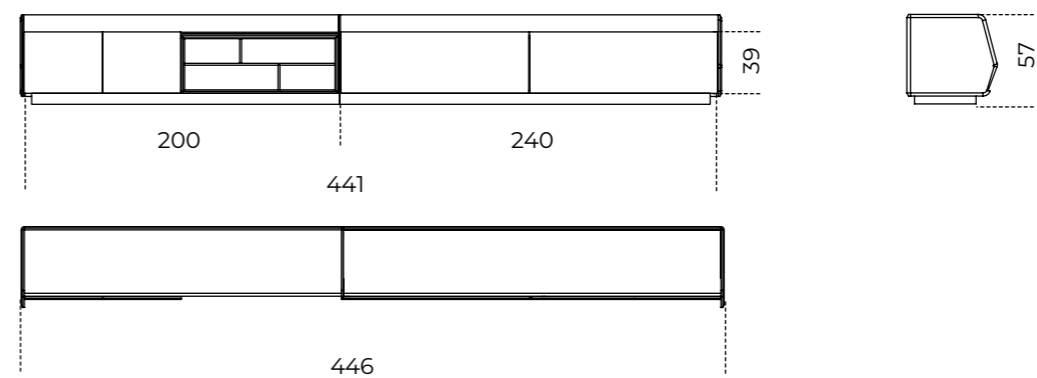
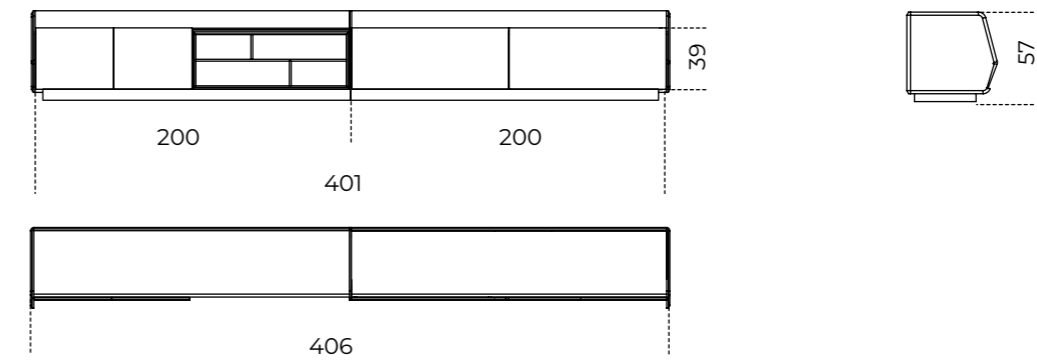
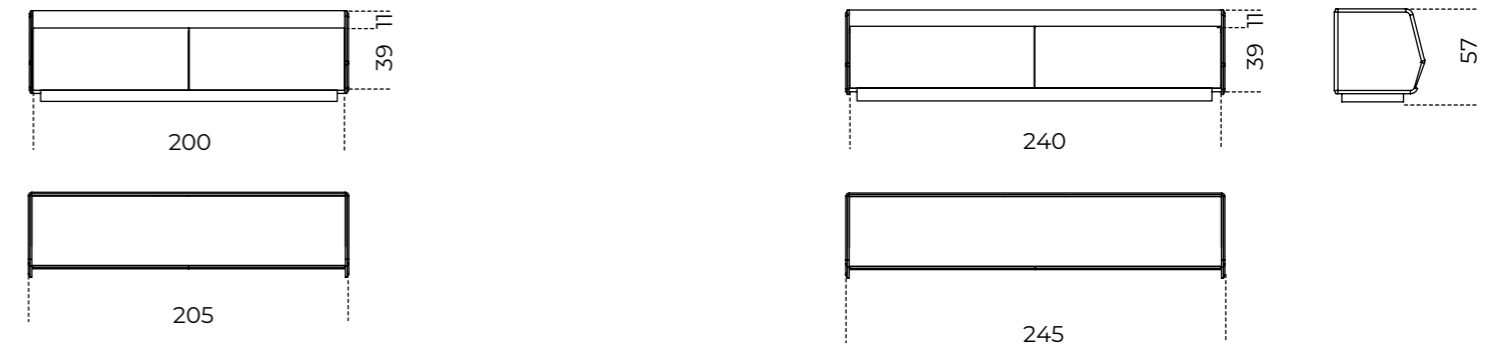

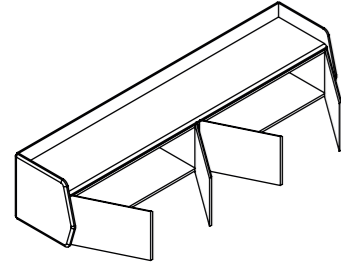
**Versione AA (ante)**  
Version AA (doors)

**Cm**  
205 x 55 x 57h  
245 x 55 x 57h

**Inches**  
80¾" x 21¾" x 22½"  
96½" x 21¾" x 22½"

**Ripiano interno in cristallo extralight**  
Inside extralight glass shelf

**Cm**  
100  
120

**Inches**  
39½"  
47¼"

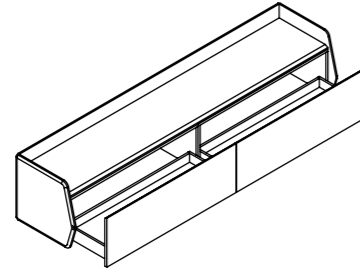
**Versione CC (cassettoni)**  
Version CC (large drawers)

**Cm**  
205 x 55 x 57h  
245 x 55 x 57h

**Inches**  
80¾" x 21¾" x 22½"  
96½" x 21¾" x 22½"

**Cassetto interno**  
Inside drawer

**Cm**  
100  
120

**Inches**  
39½"  
47¼"

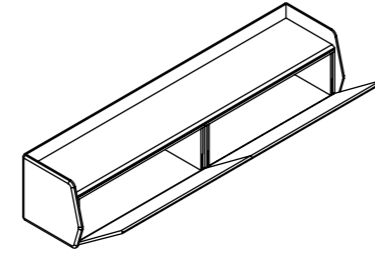
**Versione RR (ribalte)**  
Version RR (flap doors)

**Cm**  
205 x 55 x 57h  
245 x 55 x 57h

**Inches**  
80¾" x 21¾" x 22½"  
96½" x 21¾" x 22½"

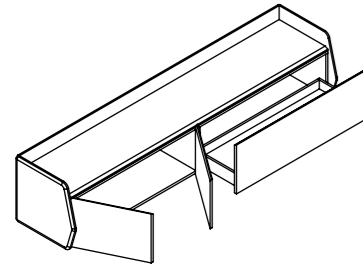
**Versione AC (ante/cassettone)**  
Version AC (doors/large drawer)

**Cm**  
205 x 55 x 57h  
245 x 55 x 57h

**Inches**  
80¾" x 21¾" x 22½"  
96½" x 21¾" x 22½"

**Ripiano interno in cristallo extralight**  
Inside extralight glass shelf**Cassetto interno**  
Inside drawer

**Cm**  
100  
120

**Inches**  
39½"  
47¼"

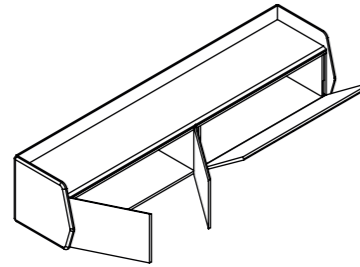
**Versione AR (ante/ribalta)**  
Version AR (doors/flap door)

**Cm**  
205 x 55 x 57h  
245 x 55 x 57h

**Inches**  
80¾" x 21¾" x 22½"  
96½" x 21¾" x 22½"

**Ripiano interno in cristallo extralight**  
Inside extralight glass shelf

**Cm**  
100  
120

**Inches**  
39½"  
47¼"

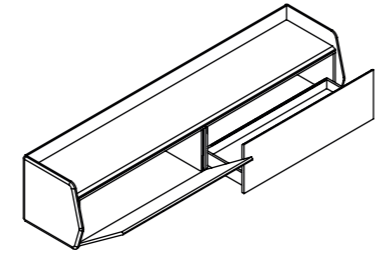
**Versione RC (ribalta/cassettone)**  
Version RC (flap door/large drawer)

**Cm**  
205 x 55 x 57h  
245 x 55 x 57h

**Inches**  
80¾" x 21¾" x 29"  
96½" x 21¾" x 29"

**Cassetto interno**  
Inside drawer

**Cm**  
100  
120

**Inches**  
39½"  
47¼"

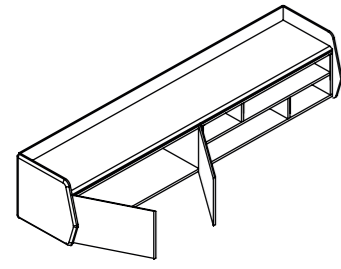
**Versione AG (ante/giorno)**  
Version AG (doors/open)

**Cm**  
205 x 55 x 57h  
245 x 55 x 57h

**Inches**  
80¾" x 21¾" x 22½"  
96½" x 21¾" x 22½"

**Ripiano interno in cristallo extralight**  
Inside extralight glass shelf

**Cm**  
100  
120

**Inches**  
39½"  
47¼"

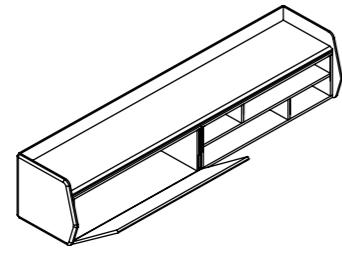
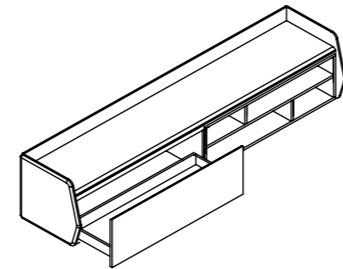
**Versione RG (ribalta/giorno)**  
Version RG (flap door/open)**Versione CG (cassettone/giorno)**  
Version CG (large drawer/open)

**Cm**  
205 x 55 x 57h  
245 x 55 x 57h

**Inches**  
80¾" x 21¾" x 29"  
96½" x 21¾" x 29"

**Cassetto interno**  
Inside drawer

**Cm**  
100  
120

**Inches**  
39½"  
47¼"

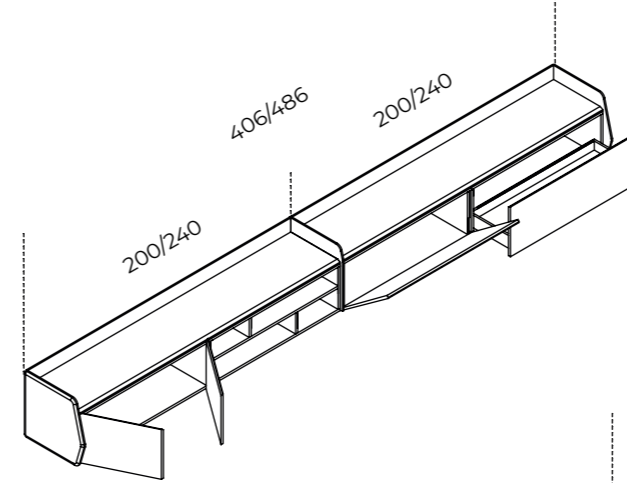
**Versione AGRC (ante/giorno/ribalta/cassettone)**  
Version AGRC (doors/open/flap door/large drawer)

**Cm**  
406 x 55 x 57  
446 x 55 x 57  
486 x 55 x 57

**Inches**  
160" x 21¾" x 22½"  
175¼" x 21¾" x 22½"  
191½" x 21¾" x 22½"

**Ripiano interno in cristallo extralight**  
Inside extralight glass shelf

**Cm**  
100  
120

**Inches**  
39½"  
47¼"

**Cassetto interno**  
Inside drawer

**Cm**  
100  
120

**Inches**  
39½"  
47¼"

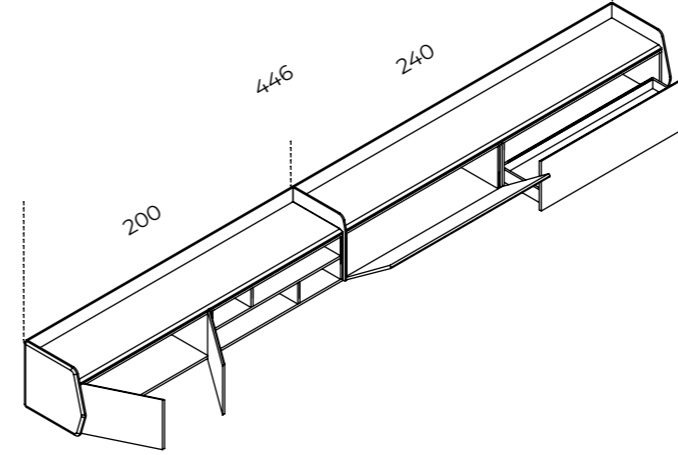
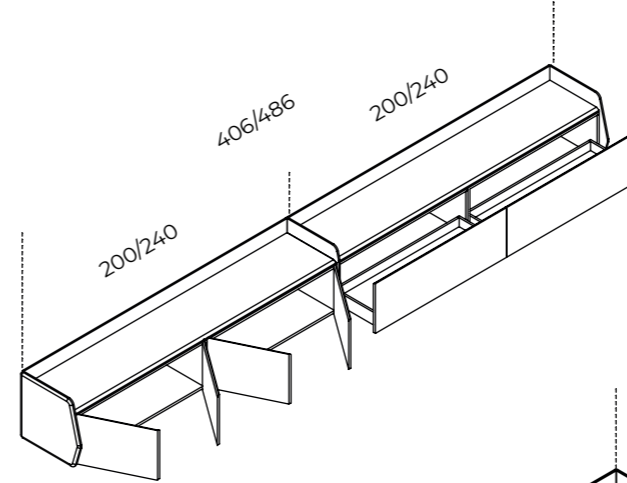
**Versione AACC (ante/cassettoni)**  
Version AACC (doors/large drawers)

**Cm**  
406 x 55 x 57  
446 x 55 x 57  
486 x 55 x 57

**Inches**  
160" x 21¾" x 22½"  
175¼" x 21¾" x 22½"  
191½" x 21¾" x 22½"

**Ripiano interno in cristallo extralight**  
Inside extralight glass shelf

**Cm**  
100  
120

**Inches**  
39½"  
47¼"

**Cassetto interno**  
Inside drawer

**Cm**  
100  
120

**Inches**  
39½"  
47¼"

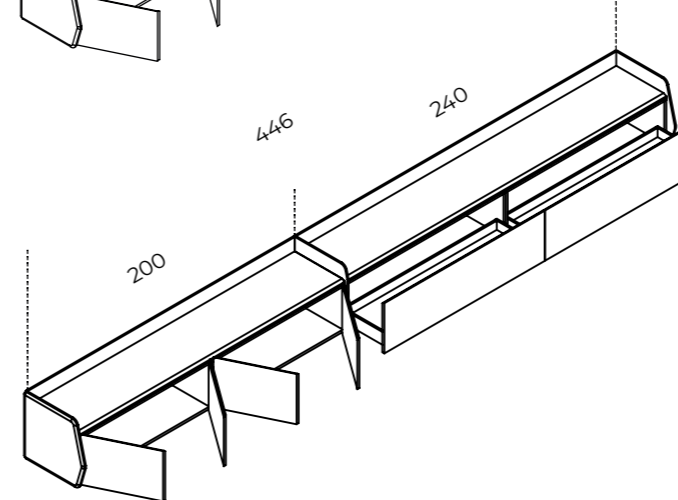

**Versione RGCC (ribalta/giorno/cassettoni)**  
Version RGCC (flap door/open/large drawers)

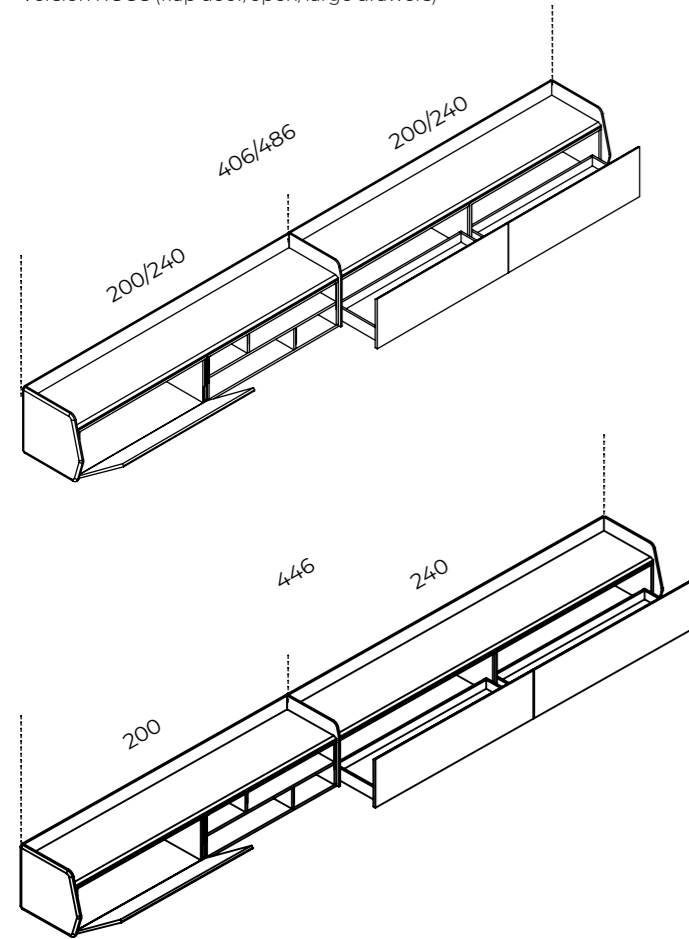

**Cm**  
406 x 55 x 57  
446 x 55 x 57  
486 x 55 x 57

**Inches**  
160" x 21¾" x 22½"  
175¼" x 21¾" x 22½"  
191½" x 21¾" x 22½"

**Ripiano interno in cristallo extralight**  
Inside extralight glass shelf

**Cm**  
100  
120

**Inches**  
39½"  
47¼"

**Cassetto interno**  
Inside drawer

**Cm**  
100  
120

**Inches**  
39½"  
47¼"

**Versione CGAA (cassettone/giorno/ante)**  
Version CGAA (large drawer/open/doors)

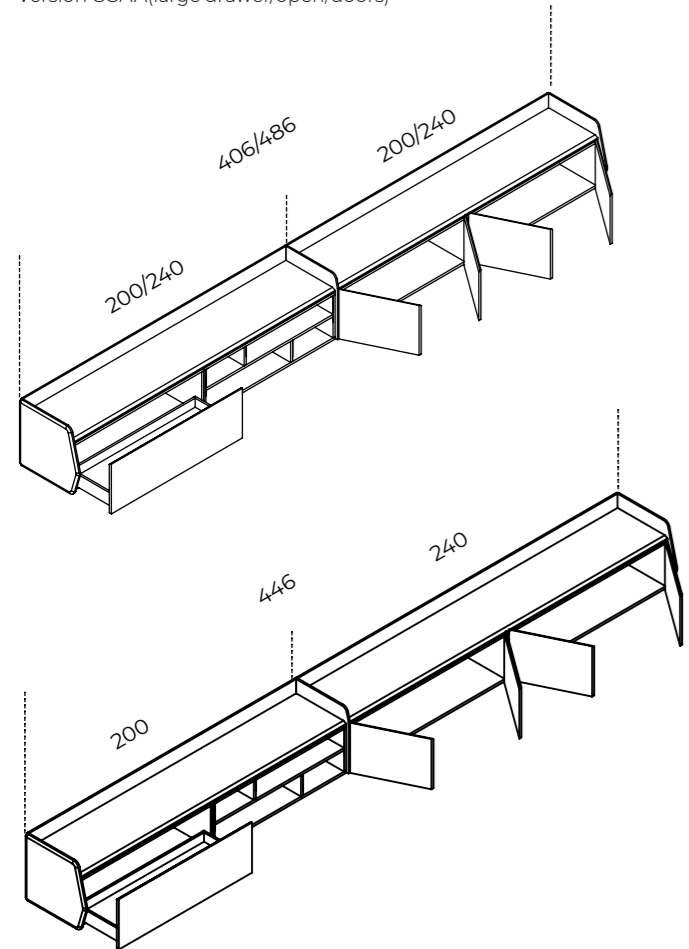

**Cm**  
406 x 55 x 57  
446 x 55 x 57  
486 x 55 x 57

**Inches**  
160" x 21¾" x 22½"  
175¼" x 21¾" x 22½"  
191½" x 21¾" x 22½"

**Ripiano interno in cristallo extralight**  
Inside extralight glass shelf

**Cm**  
100  
120

**Inches**  
39½"  
47¼"

**Cassetto interno**  
Inside drawer

**Cm**  
100  
120

**Inches**  
39½"  
47¼"

**Top in marmo (opzionale)**  
Marble top (optional)

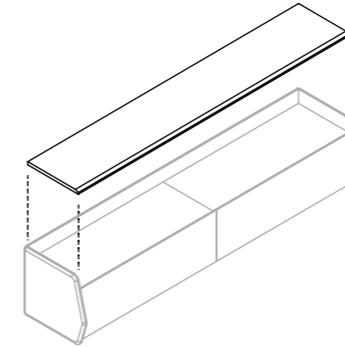

**Cm**  
200  
240

**Inches**  
78¾"  
94½"

**Mensola superiore sagomata in cristallo (opzionale)**  
Shaped upper glass shelf (optional)

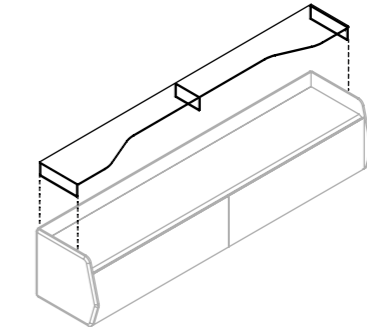

**Cm**  
200  
240

**Inches**  
78¾"  
94½"

**Hide&Seek | Pietro Russo, 2021**

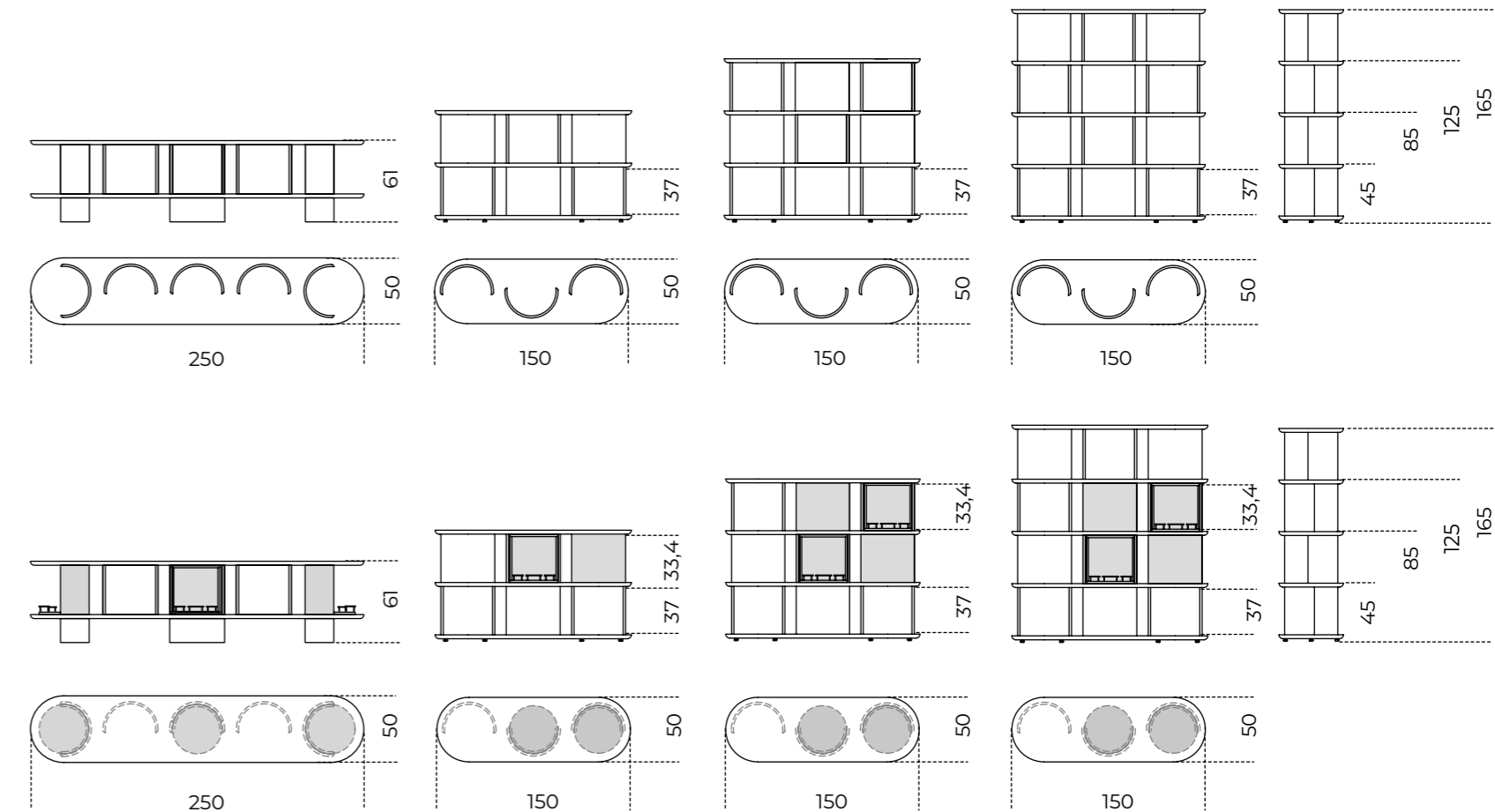

■ **Vassoi girevoli / Swivel trays**

**Hide&Seek Door** | Pietro Russo, 2024

Product information / p. 390

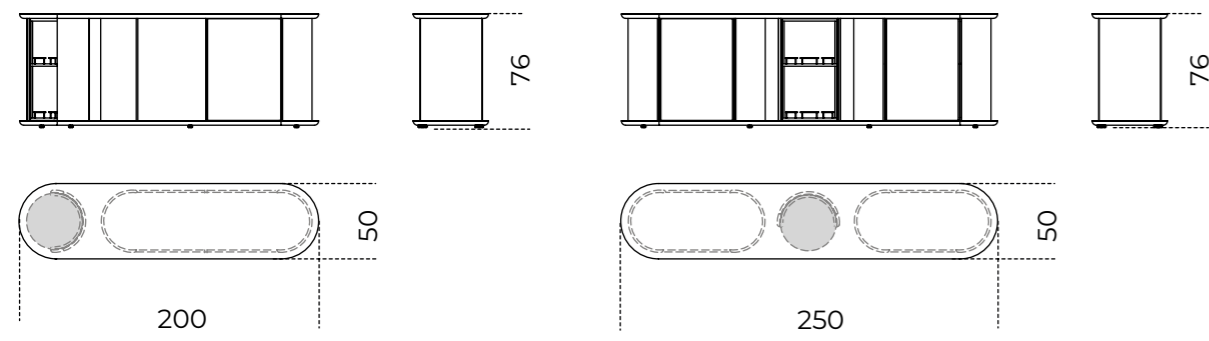

**Kumi** | Carlo Colombo, 2020

Product information / p. 392

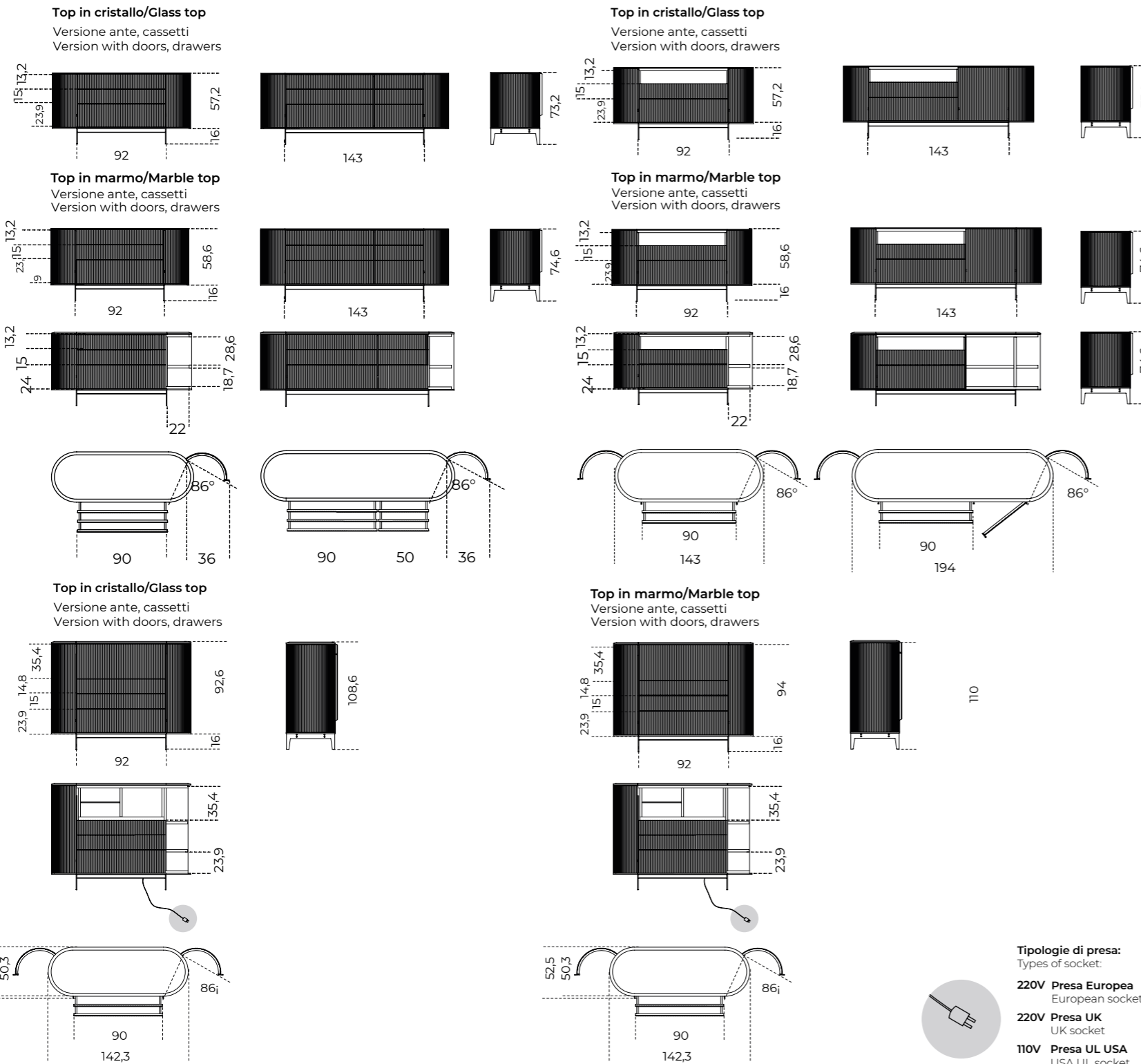

**Pandora** | Pinuccio Borgonovo, 2014

Product information / p. 394

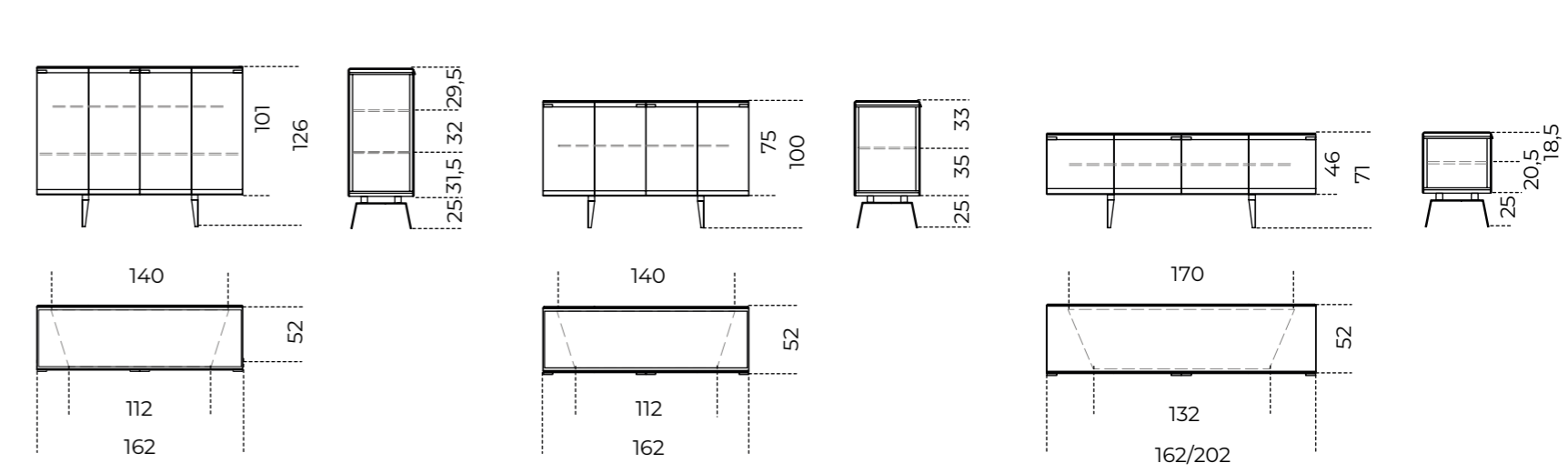

**Pandora Cashmere** | Pinuccio Borgonovo, 2020

Product information / p. 396

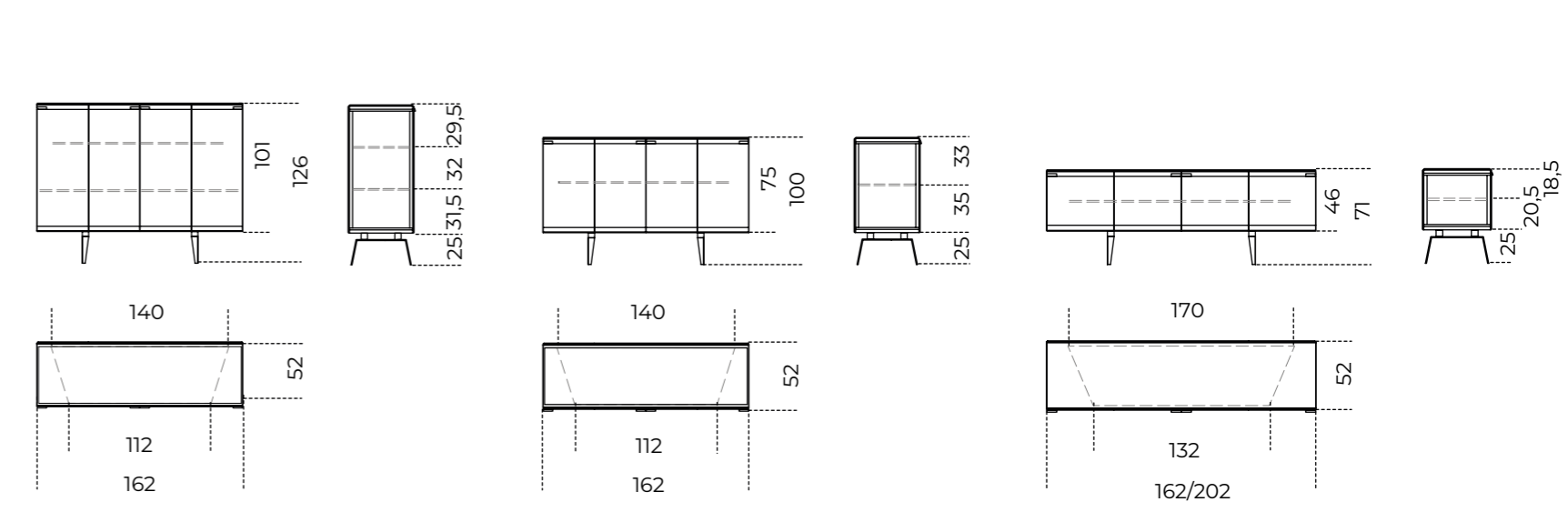

**Pandora Craquelé** | Pinuccio Borgonovo, 2016

Product information / p. 398

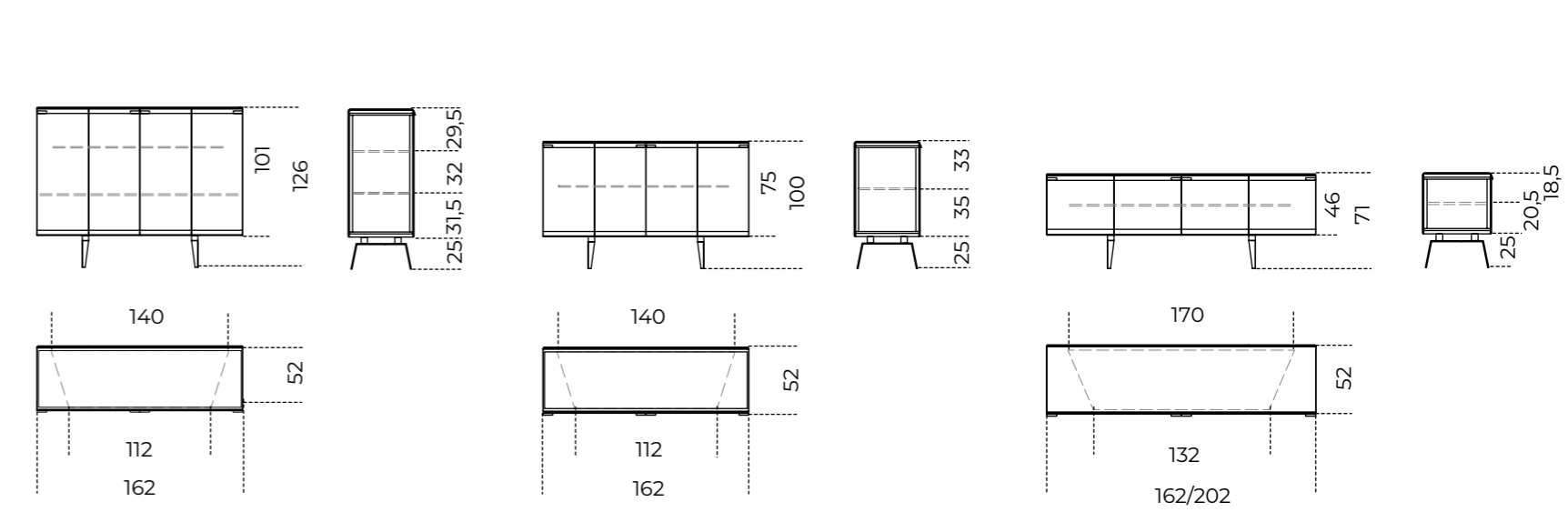

**Pandora Light** | Pinuccio Borgonovo, 2016

Product information / p. 400

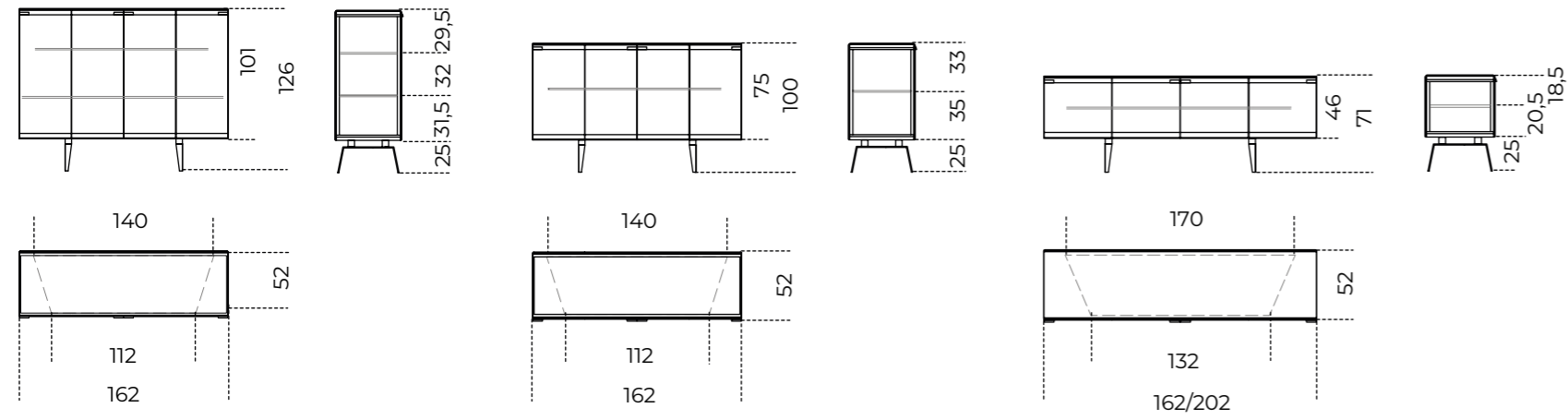

**Tama** | Carlo Colombo, 2015

Product information / p. 408

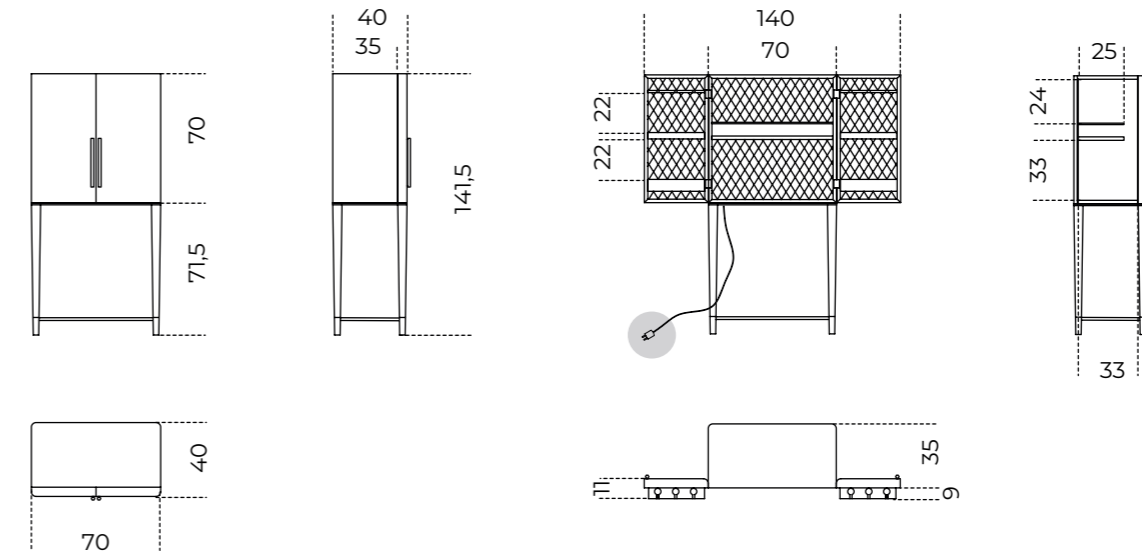

- Tipologie di presa:**  
Types of socket:
- 220V Presa Europea  
European socket
  - 220V Presa UK  
UK socket
  - 110V Presa UL USA  
USA UL socket

**Soda** | Draga & Aurel, 2022

Product information / p. 402

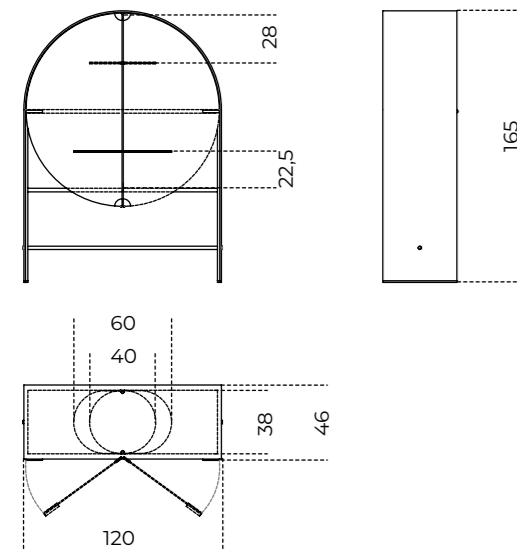

**Tama Crédence** | Carlo Colombo, 2016

Product information / p. 410

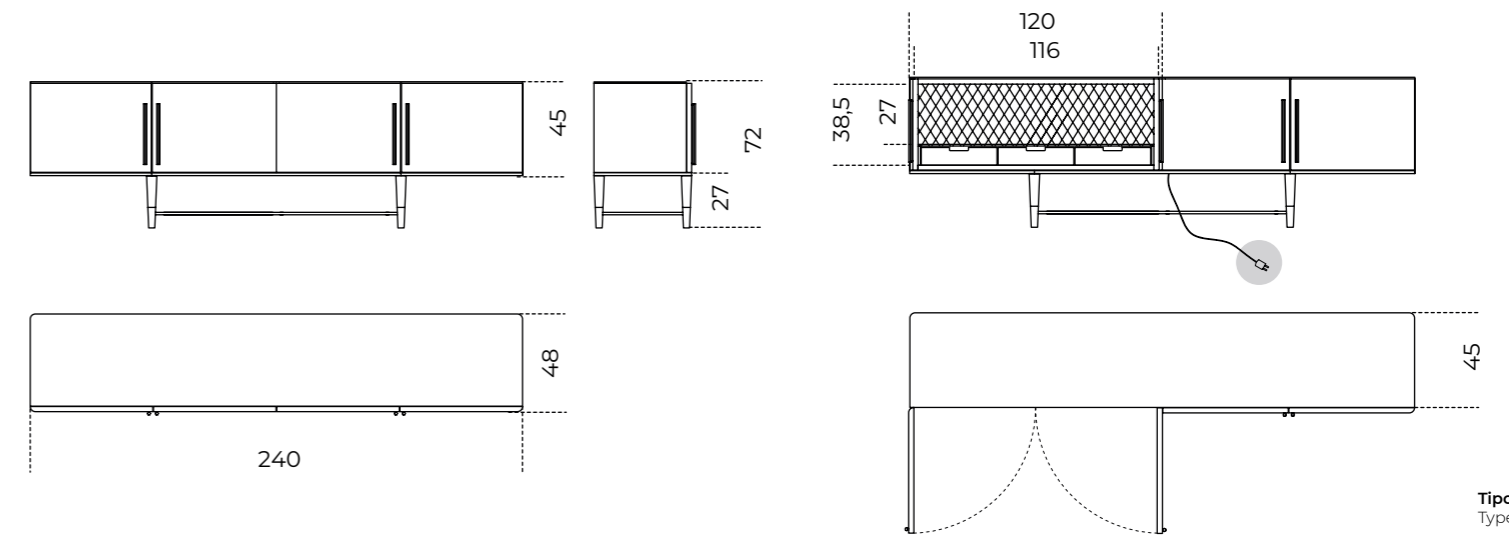

- Tipologie di presa:**  
Types of socket:
- 220V Presa Europea  
European socket
  - 220V Presa UK  
UK socket
  - 110V Presa UL USA  
USA UL socket

**Stami Sideboard** | Studiopepe, 2024

Product information / p. 406

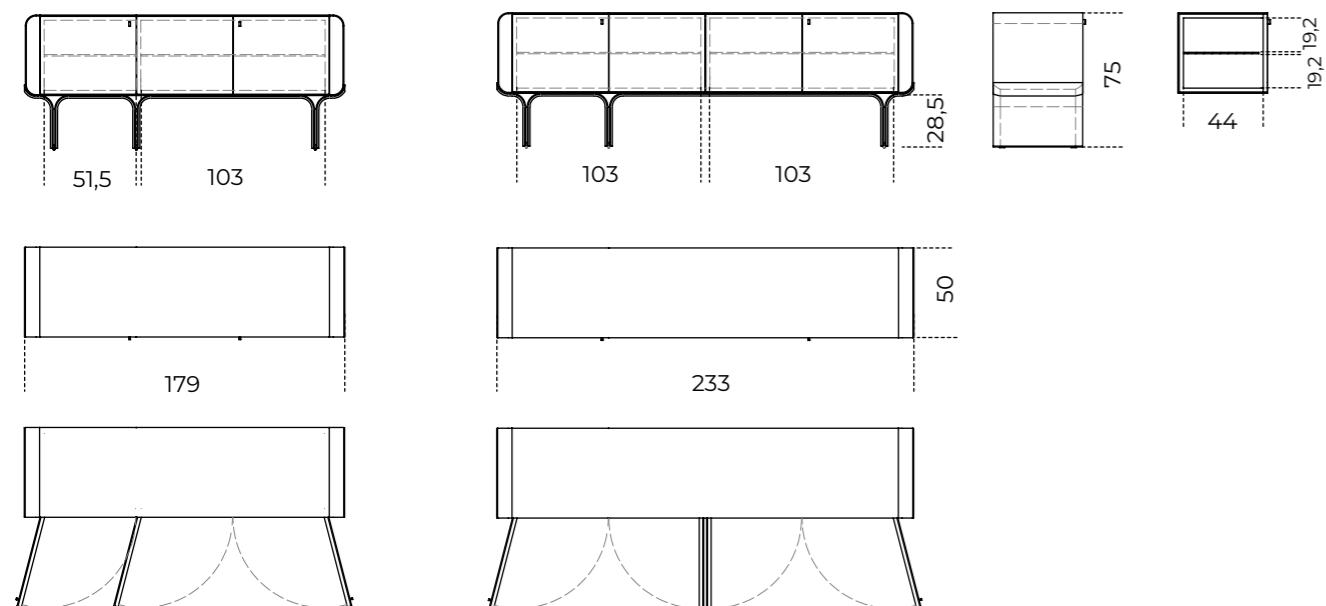

**Tama Vitrine** | Carlo Colombo, 2020

Product information / p. 412

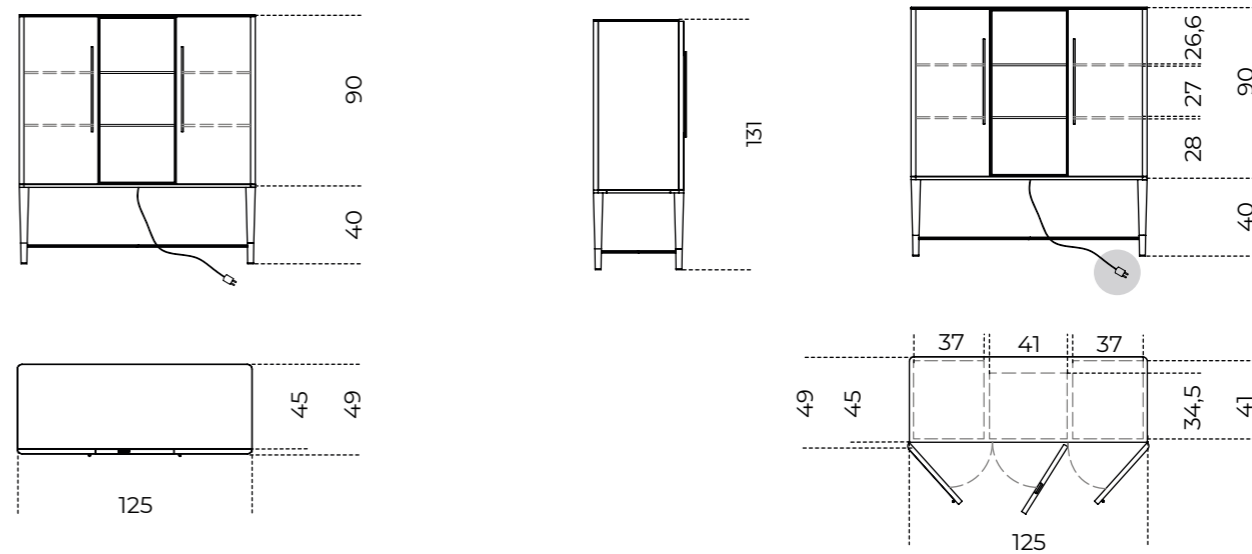

## **09** Librerie e boiserie / Shelving systems and boiserie

- [430](#) **Brera**
- [432](#) **Brera 23**
- [434](#) **Drizzle**
- [436](#) **Isola**
- [440](#) **Navigli**
- [442](#) **Pleiadi**
- [444](#) **Prism Divider**
- [448](#) **Roundcut**
- [450](#) **Syil**
- [452](#) **Tortona**
  
- [454](#) **Informazioni tecniche/**  
Technical informations



#### • BRERA

Montanti verticali in ottone nichelato satinato / Ripiani in frassino tinto nero poro aperto / Contenitore ad anta con frontale in cristallo Craquelé  
Satin nickel-plated brass vertical supports / Black open pore stained ash shelves / Door units with glass fronts in Craquelé

# Brera

Massimo Castagna / 2016

Libreria con montanti verticali in ottone nichelato satinato. Ripiani in frassino tinto nero a poro aperto. Contenitori ad anta o ribalta, con frontali in cristallo temperato decorato a mano nella finitura Craquelé. Disponibile anche con frontali in cristallo temperato retroverniciato nei colori del campionario, nella versione brillante o satinata. Su richiesta con pannello in frassino tinto nero poro aperto per posizionamento tv. Il pannello è retro illuminato a LED (30 Watt) con accensione a telecomando.

Disponibile versione con montanti verticali laccati neri e parti in legno in Noce "Colore" Frisé. Contenitori ad anta o ribalta, con frontali in cristallo 6mm temperato verniciato nella finitura metallo liquido color Lava.

! Disponibile fino ad esaurimento scorte.

\* Portata massima della mensola: 10 kg con muro pieno, uniformemente distribuiti.

#### NOTE TECNICHE SUI MATERIALI

**CRISTALLO** | Le finiture esclusive, risultato della lavorazione manuale realizzata sul cristallo, possono presentare striature e differenze cromatiche. Queste caratteristiche non devono essere considerate difetti ma elementi distintivi del processo artigianale che esaltano la bellezza e la peculiarità del pezzo unico.

**METALLO LIQUIDO** | La componente metallica della vernice fa sì che durante l'applicazione il naturale procedimento di ossidazione crei disomogeneità di sfumature che conferiscono carattere ed unicità alla superficie. Il procedimento naturale viene accentuato attraverso l'utilizzo di acidi e la spazzolatura permette di ottenere i due diversi colori.

Wall shelving system with satin nickel-plated brass vertical supports. Black open pore stained ash shelves. Door or flap door units with hand decorated tempered glass fronts Craquelé finish. Also available with painted tempered glass fronts as per samples in the bright or satin version. With black open pore stained ash TV Panel, on request. LED TV Panel (30 Watt) to be switched on with remote control.

Available version with black lacquered vertical supports and "Colore" Frisé Walnut wooden parts. Door or flap door units with 6mm tempered liquid metal lacquered glass fronts in the colour Lava.

! Available while stocks last.

\* Max capacity of the shelf: 10 kg on solid wall, evenly distributed

#### TECHNICAL INFORMATION ON THE MATERIALS

**GLASS** | Exclusive finishes, resulting from the craftsmanship on the glass, may show streaks and chromatic differences. These characteristics should not be considered imperfections but distinctive evidence of the hand-made process that enhance the beauty and peculiarity of the unique piece.

**LIQUID METAL** | The metallic component of the paint during the natural oxidation process creates uneven shades, that give uniqueness to the surface. The natural oxidation process is then enhanced by the use of acids and manual brushing to achieve the two different colours.

	Cm	Inches		Cm	Inches
60M164	60 x 25 x 164	23 3/4" x 10" x 64 3/4"	80R164	80 x 25 x 164	31 1/2" x 10" x 64 3/4"
80M164	80 x 25 x 164	31 1/2" x 10" x 64 3/4"	120R164	120 x 25 x 164	47 1/4" x 10" x 64 3/4"
120M164	120 x 25 x 164	47 1/4" x 10" x 64 3/4"	80R240	80 x 25 x 240	31 1/2" x 10" x 94 1/2"
60M240	60 x 25 x 240	23 3/4" x 10" x 94 1/2"	120R240	120 x 25 x 240	47 1/4" x 10" x 94 1/2"
80M240	80 x 25 x 240	31 1/2" x 10" x 94 1/2"			
120M240	120 x 25 x 240	47 1/4" x 10" x 94 1/2"			
160M164	160 x 25 x 164	63" x 10" x 64 3/4"	160R164	160 x 25 x 164	63" x 10" x 64 3/4"
160M240	160 x 25 x 240	63" x 10" x 94 1/2"	160R240	160 x 25 x 240	63" x 10" x 94 1/2"
60A164	60 x 25 x 164	23 3/4" x 10" x 64 3/4"	160TV164	160 x 35 x 164	63" x 14" x 64 3/4"
60A240	60 x 25 x 240	23 3/4" x 10" x 94 1/2"	160TV240	160 x 35 x 240	63" x 14" x 94 1/2"

For technical drawing / p.456

Pricelist 2023 / p. 264

Homescapes, sense of materials / pp. 32, 88, 96  
Homescapes, gentle attitude / pp. 38, 39

#### MONTANTI/ VERTICAL SUPPORTS



Ottone nichelato satinato  
Satin nickel-plated brass

#### MONTANTI/ VERTICAL SUPPORTS

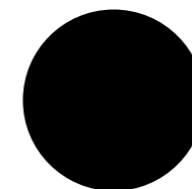

Laccato nero  
Black lacquered

#### RIPIANI E CONTENITORI/ SHELVES AND UNITS

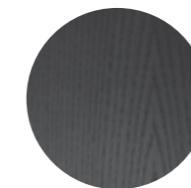

Frassino tinto  
nero poro aperto  
Black open pore stained ash

#### RIPIANI E CONTENITORI/ SHELVES AND UNITS

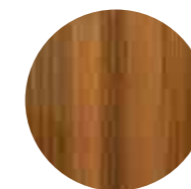

Legno Noce "Colore" Frisé  
"Colore" Frisé Walnut wood

#### ANTA O RIBALTA/ DOOR OR FLAP DOOR



Cristallo Craquelé  
Craquelé glass

#### ANTA O RIBALTA/ DOOR OR FLAP DOOR



Cristallo verniciato  
metallo liquido Lava  
Liquid metal lacquered  
Lava glass

#### PANNELLO TV/ TV PANEL

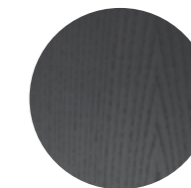

Frassino tinto  
nero poro aperto  
Black open pore stained ash

#### PANNELLO TV/ TV PANEL

LED  
30WATT

Sample box

Cristallo brillante/satinato  
nei colori del campionario  
Glass bright/satin version  
as per sample





#### • BRERA23

Montanti verticali in metallo laccato nero rivestiti in frassino laccato nero / Ripiani in legno Noce "Colore" Frisé / Contenitore ad anta con frontale in cristallo Cristallo verniciato metallo liquido Lava  
Black lacquered metal covered by black lacquered solid ash vertical supports / "Colore" Frisé Walnut wood shelves / Door units with Liquid metal lacquered Lava glass front

# Brera 23

Massimo Castagna / 2016

Libreria con montanti verticali in metallo laccato nero rivestiti in massello di frassino laccato nero. Ripiani in frassino tinto nero a poro aperto oppure Noce "Colore" Frisé. Contenitori ad anta o ribalta, con frontali in cristallo 6mm temperato decorato a mano nella finitura Craquelé o verniciato nella finitura metallo liquido color Lava. Disponibile anche con frontali in cristallo temperato retroverniciato nei colori del campionario, nella versione brillante o satinata. Disponibile con supplemento modulo vano a giorno.

Wall shelving system with black lacquered metal vertical supports covered by black lacquered solid ash. Black open pore stained ash or "Colore" Frisé Walnut shelves. Door or flap door units with 6mm hand decorated tempered glass fronts in Craquelé finish or with 6mm tempered liquid metal lacquered glass fronts in the colour Lava. Also available with 6mm painted tempered glass fronts as per samples in the bright or satin version. Available with extra charge open module.

! Portata massima della mensola: 10 kg con muro pieno, uniformemente distribuiti

! Max capacity of the shelf: 10 kg on solid wall, evenly distributed

#### NOTE TECNICHE SUI MATERIALI

**CRISTALLO** | Le finiture esclusive, risultato della lavorazione manuale realizzata sul cristallo, possono presentare striature e differenze cromatiche. Queste caratteristiche non devono essere considerate difetti ma elementi distintivi del processo artigianale che esaltano la bellezza e la peculiarità del pezzo unico.

#### TECHNICAL INFORMATION ON THE MATERIALS

**GLASS** | Exclusive finishes, resulting from the craftsmanship on the glass, may show streaks and chromatic differences. These characteristics should not be considered imperfections but distinctive evidence of the hand-made process that enhance the beauty and peculiarity of the unique piece.

**METALLO LIQUIDO** | La componente metallica della vernice fa sì che durante l'applicazione il naturale procedimento di ossidazione crei disomogeneità di sfumature che conferiscono carattere ed unicità alla superficie. Il procedimento naturale viene accentuato attraverso l'utilizzo di acidi e la spazzolatura permette di ottenere i due diversi colori.

**LIQUID METAL** | The metallic component of the paint during the natural oxidation process creates uneven shades, that give uniqueness to the surface. The natural oxidation process is then enhanced by the use of acids and manual brushing to achieve the two different colours.

	Cm	Inches
N 60M164	60 x 25 x 164	23¾" x 10" x 64¾"
N 80M164	80 x 25 x 164	31½" x 10" x 64¾"
N 120M164	120 x 25 x 164	47¼" x 10" x 64¾"
N 60M240	60 x 25 x 240	23¾" x 10" x 94½"
N 80M240	80 x 25 x 240	31½" x 10" x 94½"
N 120M240	120 x 25 x 240	47¼" x 10" x 94½"
N 160M164	160 x 25 x 164	63" x 10" x 64¾"
N 240M164	240 x 25 x 164	94½" x 10" x 64¾"
N 160M240	160 x 25 x 240	63" x 10" x 94½"
N 240M240	240 x 25 x 240	94½" x 10" x 94½"
N 60A164	60 x 35 x 164	23¾" x 14" x 64¾"
N 60A240 N	60 x 35 x 240	23¾" x 14" x 94½"
N 80R164	80 x 35 x 164	31½" x 14" x 64¾"
N 120R164	120 x 35 x 164	47¼" x 14" x 64¾"
N 80R240	80 x 35 x 240	31½" x 14" x 94½"
N 120R240	120 x 35 x 240	47¼" x 14" x 94½"
N 160R240	160 x 35 x 164	63" x 14" x 64¾"
N 240R164	240 x 35 x 164	94½" x 14" x 64¾"
N 160R240	160 x 35 x 240	63" x 14" x 94½"
N 240R240	240 x 35 x 240	94½" x 14" x 94½"

For technical drawing / p. 457

Pricelist 2023 / p. 266  
Homescapes, sense of materials / pp. 32, 88, 96  
Homescapes, gentle attitude / pp. 38, 39

#### MONTANTI/ VERTICAL SUPPORTS

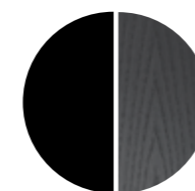

Metallo laccato nero rivestiti in massello di frassino laccato nero  
Black lacquered metal covered by black lacquered solid ash

#### RIPIANI E CONTENITORI/ SHELVES AND UNITS

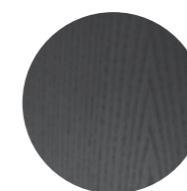

Frassino tinto nero poro aperto  
Black open pore stained ash

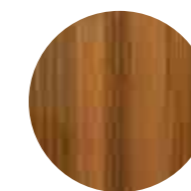

Legno Noce "Colore" Frisé  
"Colore" Frisé Walnut wood

#### ANTA O RIBALTA/ DOOR OR FLAP DOOR



Cristallo Craquelé  
Craquelé glass



Cristallo verniciato metallo liquido Lava  
Liquid metal lacquered Lava glass



Cristallo brillante/satinato nei colori del campionario  
Glass bright/satin version as per sample



▲ **DRIZZLE**  
Struttura in alluminio anodizzato nero /  
Reggipiani in ottone satinato / Piani in cristallo extralight  
Black anodised aluminium structure /  
Satin brass supports / Extralight glass shelves

# Drizzle

Luca Nichetto / 2012

Libreria modulare con struttura in alluminio anodizzato nero e reggipiani in ottone satinato. Piani in cristallo extralight temperato 8mm. Disponibile anche in cristallo "grigio Italia" 8mm.

Modular shelving system with black anodised aluminium structure and satin brass shelf supports. 8mm extralight tempered glass shelves. Also available in 8mm smoked "grigio Italia" glass.

! Portata massima del ripiano: 10 kg uniformemente distribuito

! Max capacity of the shelf: 10 kg evenly distributed



#### Cm

80 x 37,5 x 67,5\*  
80 x 37,5 x 114,5\*  
80 x 37,5 x 147\*  
80 x 37,5 x 194\*  
100 x 37,5 x 67,5\*\*  
100 x 37,5 x 114,5\*\*  
100 x 37,5 x 147\*\*  
100 x 37,5 x 194\*\*

#### Misura dei ripiani

\*80 x 34  
\*\*100 x 34

#### Inches

31½" x 15" x 26¾"  
31½" x 15" x 45¼"  
31½" x 15" x 58"  
31½" x 15" x 76½"  
39½" x 15" x 26¾"  
39½" x 15" x 45¼"  
39½" x 15" x 58"  
39½" x 15" x 76½"

#### Sizes of the shelves

\*31½" x 13½"  
\*\*39½" x 13½"

For technical drawing / p.458

Pricelist 2023 / p.268

#### STRUTTURA/STRUCTURE



Alluminio anodizzato nero  
Black anodised aluminium

#### REGGIPIANI/ SUPPORTS



Ottone satinato  
Satin brass

#### PIANI/SHELVES



Cristallo extralight  
Extralight glass



Cristallo "grigio Italia"  
"Grigio Italia" glass



▲ ISOLA  
Struttura in cristallo extralight / Ripiani in ottone satinato  
Extralight glass structure / Satin brass shelves

# Isola

Massimo Castagna / 2016

Libreria a spalla portante in cristallo extralight 12mm temperato.  
Disponibile anche in cristallo "grigio Italia" 12mm temperato.  
Ripiani in ottone satinato oppure in ottone satinato argentato.  
Borchie tornite e godronate in ottone lucido.

! Non realizzabile su misura.  
Portata massima del ripiano: 2kg

Freestanding shelving system in 12mm extralight tempered glass.  
Also available in 12mm smoked "grigio Italia" tempered glass.  
Satin or satin silver-plated brass shelves.  
Bright brass turned and knurling knobs.

! Not available in custom size.  
Max capacity of the shelf: 2kg



**Cm**  
61 x 25 x 183  
120 x 25 x 183

**Inches**  
24¼" x 10" x 72¼"  
47¼" x 10" x 72¼"

[For technical drawing / p.458](#)

[Pricelist 2023 / p.269](#)

## STRUTTURA/STRUCTURE



Cristallo extralight  
Extralight glass



Cristallo "grigio Italia"  
"Grigio Italia" glass

## RIPIANI/SHELVES



Ottone satinato  
Satin brass



Ottone satinato argentato  
Satin silver-plated brass

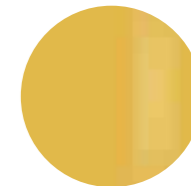

Ottone lucido  
Bright brass

## BORCHIE/KNOBS

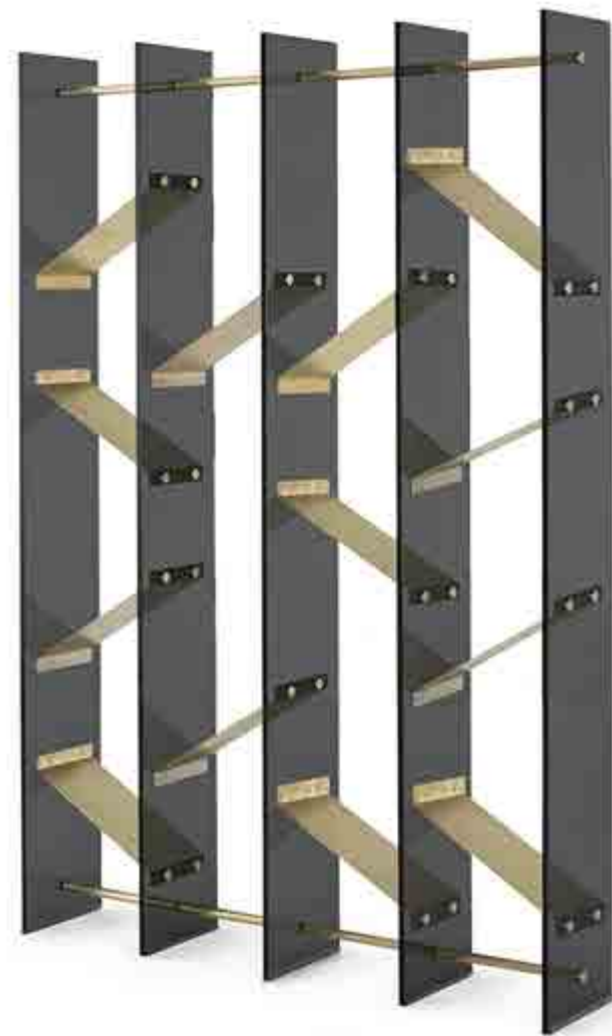

• ISOLA  
Struttura in cristallo "grigioitalia" / Ripiani in ottone satinato  
"Grigio Italia" glass structure / Satin brass shelves

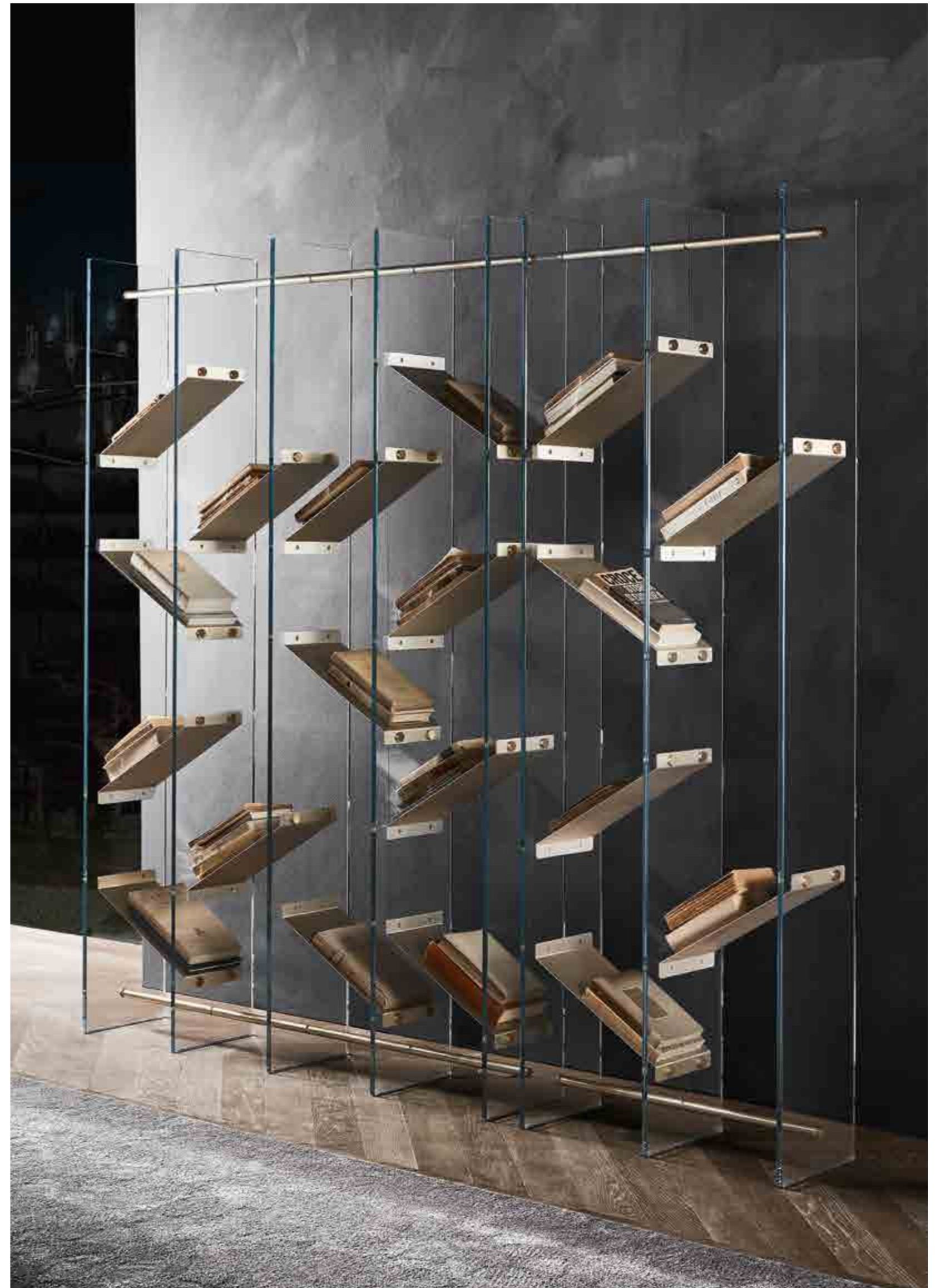

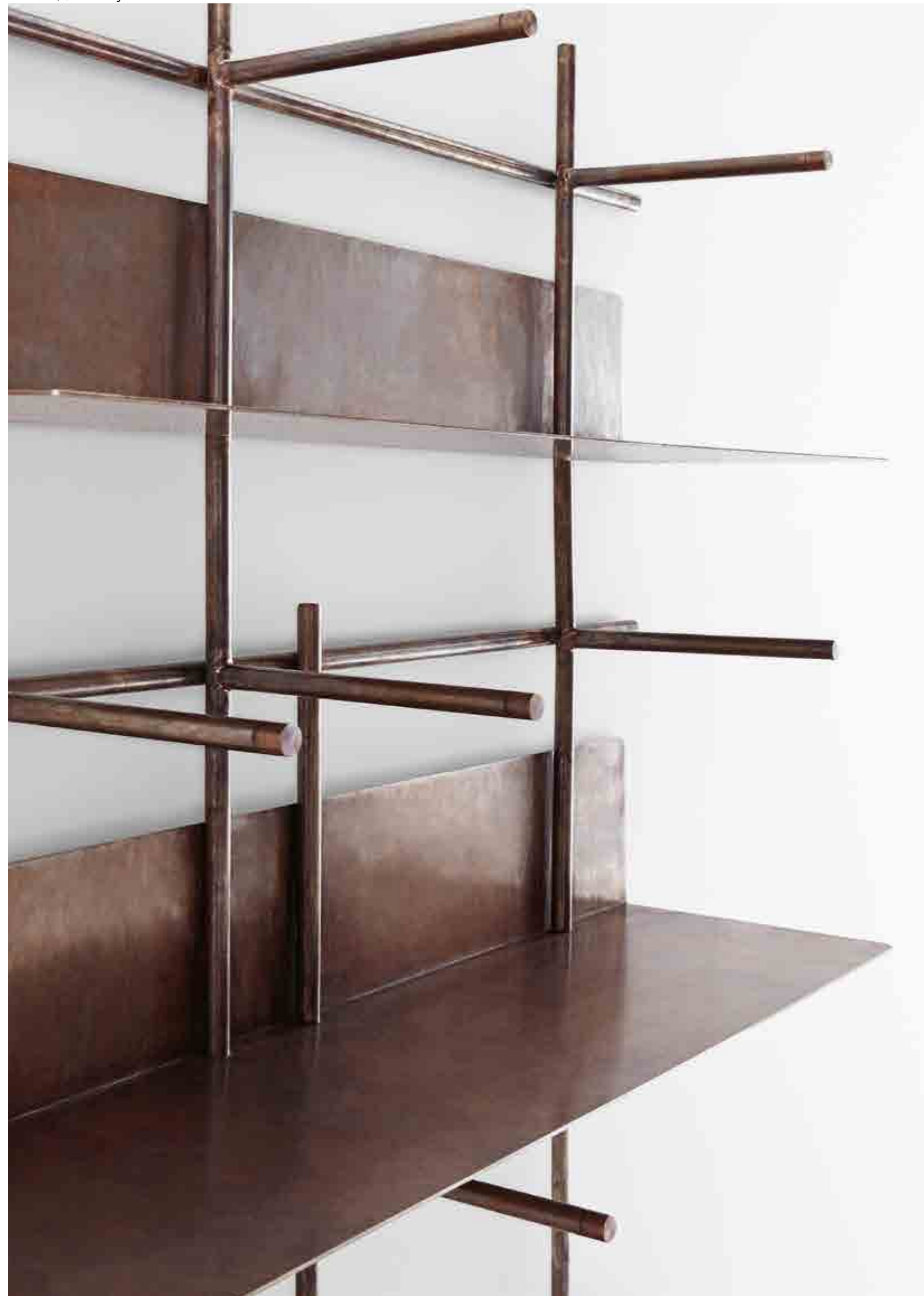

# Navigli

Massimo Castagna / 2015

Libreria a muro con struttura e mensole in rame brunito a mano. Il rame risulta naturalmente macchiato e disomogeneo. Questa lavorazione artigianale conferisce ad ogni pezzo una particolare unicità, rendendolo esclusivo. Disponibile in due versioni A e B.

! Portata massima della mensola: 5 kg con muro pieno, uniformemente distribuiti

## NOTE TECNICHE SUI MATERIALI

**RAME BRUNITO A MANO** | Il rame brunito a mano è ottenuto da un processo di ossidazione naturale eseguito manualmente. Il risultato di questa lavorazione è un prodotto che può presentare macchie e variazioni di colore che non sono da considerarsi imperfezioni ma caratteristiche che conferiscono ad ogni pezzo una particolare unicità, rendendolo esclusivo.

Wall shelving system with hand burnished copper structure and shelves. The hand burnished copper finish looks naturally spotted and irregular. Due to this craftmade processing, each product is unique and exclusive. Available in two versions A and B.

! Max capacity of the shelf: 5 kg on solid wall evenly distributed

## TECHNICAL INFORMATION ON THE MATERIALS

**HAND BURNISHED COPPER** | The hand burnished copper is the consequence of handmade process of natural oxidation. The result of this processing is a product that may show marks and colour variations. These differences are inevitable and should not be considered imperfections but evidence of the hand-crafted process. They enhance the beauty and distinctiveness of a unique piece.



A



B

	Cm	Inches
A	70 x 24 x 120	27 3/4" x 9 1/2" x 47 1/4"
B	70 x 24 x 120	27 3/4" x 9 1/2" x 47 1/4"

For technical drawing / p.458

Pricelist 2023 / p.270  
Homescapes, sense of materials / p.111  
Homescapes, embracing beauty / p.105

## STRUTTURA E MENSOLE/STRUCTURE AND SHELVES

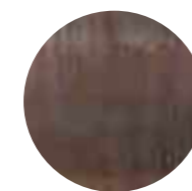

Rame brunito a mano  
Hand burnished copper



# Pleiadi

Sutdiopepe/2023

Rivestimento decorativo realizzato in linters di cotone e argille e ottenuto tramite un processo di lavorazione artigianale a freddo. I linters sono la peluria corta che avvolge il seme del cotone dopo la prima sgranatura. Staccati, con una seconda e più energica sgranatura, forniscono fibre di cellulosa molto pura, solitamente utilizzate nell'industria cartaria o per la produzione di ovatte, stoppini, feltri e filati di viscosa.

La mattonella decorativa Pleiadi è ecologica e sostenibile, offrendo una nuova vita e una nuova funzionalità a quello che viene generalmente considerato uno scarto della produzione del cotone.

Disponibile nel colore "nature", una finitura ispirata al mondo naturale, ottenuta anch'essa in modo artigianale con la miscelazione di terre naturali e senza l'aggiunta di coloranti artificiali né di mordenti. Ciascuna mattonella misura 20x20 cm e può essere posizionata sia orizzontalmente che verticalmente per creare diverse composizioni ed effetti grafici. Trattandosi di un prodotto realizzato artigianalmente e manualmente, la dimensioni potrebbero variare leggermente.

La composizione in cellulosa di Pleiadi garantisce elevate performance di assorbimento sonoro a fronte di spessori estremamente ridotti.

! Trattandosi di un prodotto realizzato artigianalmente e manualmente, la dimensioni potrebbero variare leggermente.

## NOTE TECNICHE SUI MATERIALI

FINITURE ARTIGIANALI | Le finiture manuali ed esclusive risultato del processo di ossidazione di foglia argento, oro e rame possono presentare macchie e striature, oltre a differenze cromatiche. Tali disomogeneità sono caratteristiche che non devono essere considerate difetti ma elementi distintivi, tipici dell'ossidazione manuale, che esaltano la bellezza e la peculiarità del pezzo unico.

Decorative wallcovering made of cotton linters and clays and obtained through a cold craft process. Linters are the short downy hairs or fuzz adhering to the cotton seeds. After removal from the seeds, the linters receive a second, more energetic ginning to produce very pure cellulose fibres, mostly used for paper, wadding, wicks, felt and viscose yarns.

The decorative tile Pleiadi is ecological and sustainable, giving a new life and new use to what is generally considered a by-product of the cotton industry.

Available in 'nature' colour, a natural finish obtained in a low-tech process by mixing earth without artificial dyes or mordant. Each tile measures 20x20 cm and can be placed both horizontally and vertically to create different compositions and graphic effects.

As this is a handcrafted and manually made product, the dimensions may vary slightly. The cellulose composition of Pleiadi guarantees high sound absorption performance against extremely low thicknesses

! As this is a handcrafted and manually made product, the dimensions may vary slightly.

## TECHNICAL INFORMATION ON THE MATERIALS

ARTISANAL FINISHES | Artisanal and exclusive finishes that are obtained from the oxidation of silver, gold and copper leaves may show marks and spots, as well as variations in colour. These differences are inevitable and should not be considered imperfections but evidence of the hand-crafted process. They enhance the beauty and distinctiveness of a unique piece.

**AL MOMENTO NON DISPONIBILI  
CURRENTLY NOT AVAILABLE**



Cm  
20 x 3 x 20

Inches  
8" x 1¼" x 8"

[For technical drawing / p. 459](#)

[Pricelist 2023 / p. 271](#)

## LINTERS DI COTONE E ARGILLE / COTTON LINTERS AND CLAYS



"Nature"

# Prism Divider

David/Nicolas / 2021

Libreria a colonna modulare in legno Noce Colore Frisé o frassino tinto nero a poro aperto. Parti metalliche in ottone satinato. Disponibile versione a due e a tre ripiani. Affiancando due o più colonne si possono creare composizioni di diverse dimensioni.

! Eventuali composizioni sono da comunicare al momento dell'ordine.

Il legno è un materiale vivo che subisce un naturale processo di ossidazione che può causare cambiamenti cromatici. Venature e tonalità di colore differenti delle lastre non sono da considerarsi come difetti, ma caratteristiche che esaltano l'unicità del materiale.

## NOTE TECNICHE SUI MATERIALI

**INTARSIO** | L'intarsio è una tecnica di lavorazione artigianale utilizzata per ottenere un particolare disegno e si realizza accostando elementi di materiali differenti (come legno e alluminio) oppure dello stesso materiale. Questa lavorazione rende il prodotto unico ed esclusivo. Le eventuali variazioni cromatiche e di venatura del legno sono da considerarsi caratteristiche del materiale stesso e non possono essere controllate.

Modular column bookcase in "Colore" Frisé Walnut or black open pore stained ash. Satin brass metal parts. Available with two or three shelves. Placing together two or more modules allow to create various compositions.

! Compositions are to be specified when ordering.

Wood is a living material and the natural oxidation process can cause chromatic changes. Different grain and colour shades of the wooden slabs are not to be considered as defects, but characteristics that enhance the uniqueness of the material.

## TECHNICAL INFORMATION ON THE MATERIALS

**INLAY** | Inlay is an artisanal technique used to obtain a particular design and is made by combining elements of different materials (such as wood and aluminium) or of the same material. This process makes the product unique and exclusive. Any colour and grain variations of the wood are to be considered as characteristics of the material itself and cannot be controlled.



	Cm	Inches
<b>A53</b>	53 x 40 x 183	21" x 15¾" x 72¼"
<b>A83</b>	83 x 40 x 183	32¾" x 15¾" x 72¼"
<b>B53</b>	53 x 40 x 183	21" x 15¾" x 72¼"
<b>B83</b>	83 x 40 x 183	32¾" x 15¾" x 72¼"

For technical drawing / p. 459

Pricelist 2023 / p. 272  
Homescapes, intimate portraits / p. 65, 102  
Homescapes, gentle attitude / p. 45

▲ PRISM DIVIDER  
Legno Noce "Colore" Frisé/Dettagli ottone satinato  
"Colore" Frisé Walnut wood/Satin brass details

## STRUTTURA / STRUCTURE



Legno Noce "Colore" Frisé  
"Colore" Frisé Walnut wood

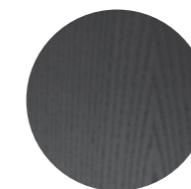

Frassino tinto nero poro aperto  
Black open pore stained ash

## DETTAGLI / DETAILS



Ottone satinato  
Satin brass



A53



A83



B53



B83





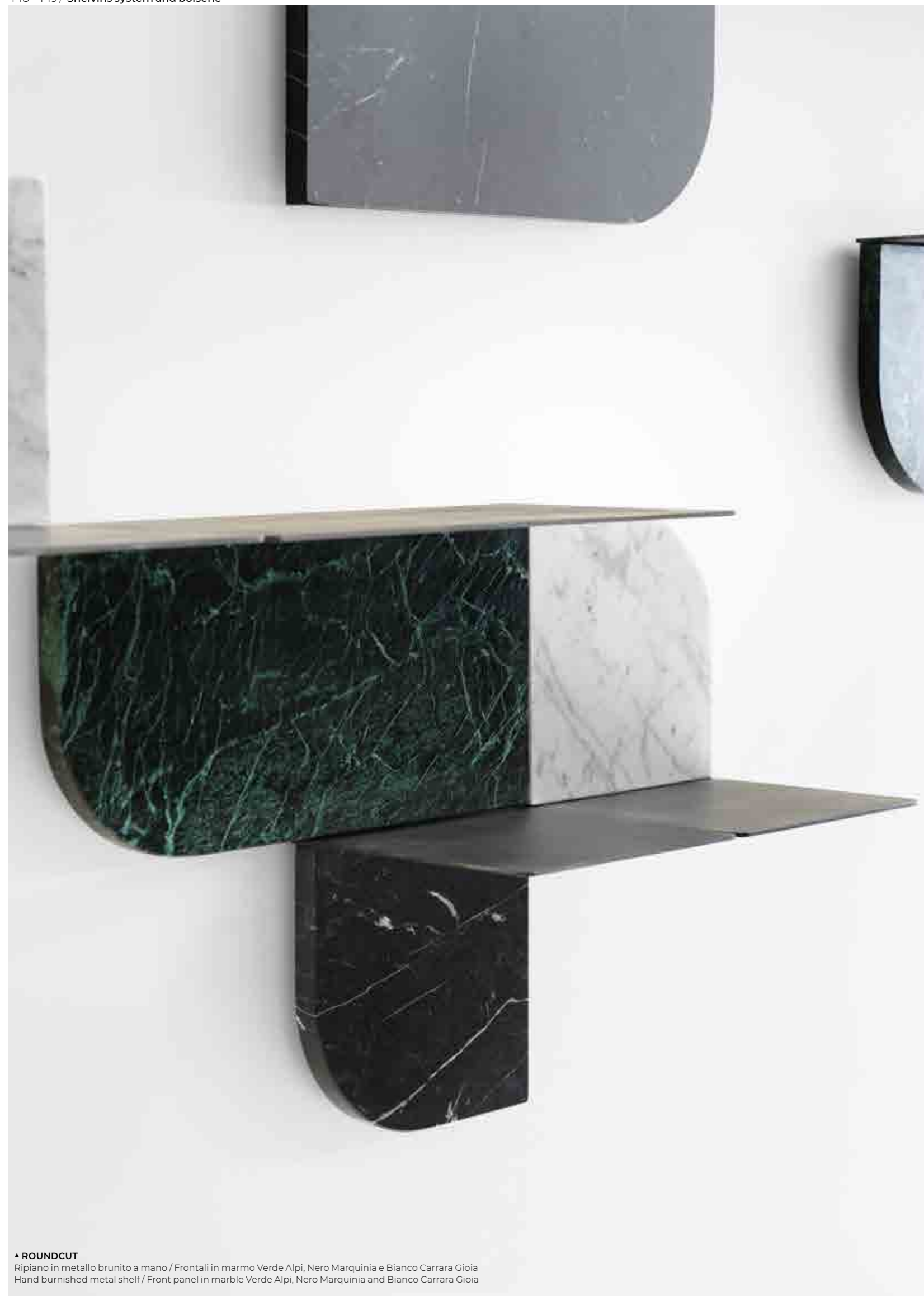

▲ **ROUND CUT**  
Ripiano in metallo brunito a mano / Frontali in marmo Verde Alpi, Nero Marquinia e Bianco Carrara Gioia  
Hand burnished metal shelf / Front panel in marble Verde Alpi, Nero Marquinia and Bianco Carrara Gioia

# Roundcut

Studiopepe/2020

Sistema modulare di mensole con ripiano in metallo brunito a mano. Frontale in marmo a scelta tra Bianco Carrara Gioia lucido naturale, Calacatta Vagli Oro lucido naturale, Stardust Grey lucido naturale, Verde Alpi lucido naturale, Nero Marquinia lucido naturale, Fior di Pesco spazzolato, Travertino Romano spazzolato, "Ceppo dei Volpi" lucido naturale, "Ceppo Antico" lucido naturale oppure disponibile in specchio extralight 6mm. Versione sinistra (L) e destra (R) per ciascuna misura. Le mensole possono essere installate in due diverse posizioni (con mensola sopra o sotto), ruotandole di 180°.

! Portata massima della mensola:  
Small=5 kg  
Medium=8 kg  
Large=10 kg

## NOTE TECNICHE SUI MATERIALI

**MARMO/TRAVERTINO** | Il marmo è un materiale naturale di origine sedimentaria che può presentare particolarità come venature, lievi irregolarità superficiali, colorazioni differenti e cristallizzazioni. Queste peculiarità sono da attribuirsi alla naturalezza del materiale e non sono da considerarsi difetti ma caratteristiche tipiche del marmo. Ogni prodotto risulterà unico, esclusivo e non replicabile.

Modular shelving system with shelf in hand burnished metal. Front panel in marble available in natural polished Bianco Carrara Gioia, natural polished Calacatta Vagli Oro, natural polished Stardust Grey, natural polished Verde Alpi, natural polished Nero Marquinia, brushed Fior di Pesco, brushed Travertino Romano, natural polished "Ceppo dei Volpi", natural polished "Ceppo Antico" or in 6mm extralight mirror. Each size available in the left (L) and right (R) versions. Shelves may be fitted in two locations (with shelf above or below) rotating them by 180°.

! Max capacity of the shelf:  
Small=5 kg  
Medium=8 kg  
Large=10 kg

## TECHNICAL INFORMATION ON THE MATERIALS

**MARBLE/TRAVERTINO** | The marble is a natural material of sedimentary origin that can present particularities such as veins, slight surface irregularities, different colors and crystallizations. These peculiarities are to be attributed to the naturalness of the material and are not to be considered defects but typical characteristics of marble. Each product will be unique, exclusive and non-replicable.



	Cm	Inches
Small L/R	20 x 20 x 20	8" x 8" x 8"
Medium L/R	40 x 20 x 20	15¾" x 8" x 8"
Large L/R	80 x 20 x 20	31½" x 8" x 8"

For technical drawing / p.461

Pricelist 2023 / p.274

Homescapes, embracing beauty / p.18  
Homescapes, gentle attitude / p.51

## RIPIANO/SHELF



Metallo brunito a mano "dark"  
"Dark" hand burnished metal

## FRONTALE/FRONT PANEL

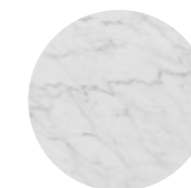

Marmo lucido naturale Bianco Carrara Gioia  
Natural polished Bianco Carrara Gioia marble



Marmo lucido naturale Calacatta Vagli Oro  
Natural polished Calacatta Vagli Oro marble



Marmo lucido naturale Stardust Grey  
Natural polished Stardust Grey marble



Marmo lucido naturale Verde Alpi  
Natural polished Verde Alpi marble



Marmo lucido naturale Nero Marquinia  
Natural polished Nero Marquinia marble



Marmo spazzolato Fior di Pesco  
Brushed Fior di Pesco marble



Travertino Romano spazzolato  
Natural brushed Travertino Romano



Marmo lucido naturale "Ceppo dei Volpi"  
Natural polished "Ceppo dei Volpi" marble



Marmo lucido naturale "Ceppo Antico"  
Natural polished "Ceppo Antico" marble



Specchio extralight  
Extralight mirror



# Syil

Oscar e Gabriele Buratti / 2019

Sistema con montanti in alluminio anodizzato nero con dettagli in ottone lucido. Ripiani sagomati in cristallo grigio Italia 8mm temperato retroverniciato nero brillante. Contenitori ad anta, ribalta o cassetto in legno laccato lucido nei colori blu grigio, liquirizia e nero. Interno in frassino tinto nero poro aperto. Contenitore ad anta con ripiano interno in cristallo extralight temperato 8mm. Disponibile anche modulo con pannello porta tv con contenitore a ribalta. Su richiesta può essere dotato di passacavi.

Shelving system with black anodised aluminium supports with bright brass details. 8mm tempered shaped bright black painted smoked "grigio Italia" glass shelves. Wooden glossy lacquered door unit, flap door or drawer units in the colours blue-grey, liquorice and black. Black open pore stained ash interior. Door unit with 8mm tempered inside extralight glass. Also available module with Tv panel and flap door unit, supplied with cable management, on request.

! Consigliato fissaggio a parete con ferramenta inclusa.

! Recommended wall fixing with included hardware.



## Cm

123 x 47 x 70  
123 x 47 x 132  
123 x 47 x 158  
183 x 47 x 158  
123 x 47 x 194  
183 x 47 x 194  
123 x 47 x 256  
183 x 47 x 256

## Inches

48½" x 18¾" x 23¾"  
48½" x 18¾" x 52"  
48½" x 18¾" x 62¼"  
72¼" x 18¾" x 62¼"  
48½" x 18¾" x 76½"  
72¼" x 18¾" x 76½"  
48½" x 18¾" x 101"  
72¼" x 18¾" x 101"

For technical drawing / pp.462-468

Pricelist 2023 / p. 277  
Homescapes, sense of materials / p. 8  
Homescapes, embracing beauty / pp. 39,41  
Homescapes, gentle attitude / p. 90

## MONTANTI/SUPPORTS



Alluminio anodizzato nero  
Black anodised aluminium

## DETTAGLI/DETAILS



Ottone lucido  
Bright brass

## RIPIANI/SHELVES

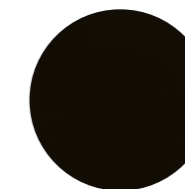

Cristallo "grigio Italia"  
retroverniciato nero  
brillante  
Bright black painted  
smoked "grigio Italia" glass

## RIPIANO INTERNO/ INSIDE SHELVES



Cristallo extralight  
Extralight mirror

## CONTENITORI/UNITS

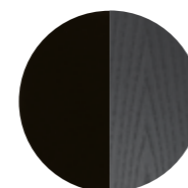

Esterno- legno laccato  
lucido nero /  
Interno- frassino tinto  
nero a poro aperto  
Outside- glossy lacquered  
black wood /  
Inside- black open pore  
lacquered ash

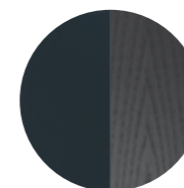

Esterno- legno laccato  
lucido blu-grigio /  
Interno- frassino tinto  
nero a poro aperto  
Outside- glossy lacquered  
blue-grey wood /  
Inside- black open pore  
lacquered ash

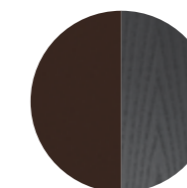

Esterno- legno laccato  
lucido liquirizia /  
Interno- frassino tinto  
nero a poro aperto  
Outside- glossy lacquered  
liquorice wood /  
Inside- black open pore  
lacquered ash



▲ **TORTONA**  
Struttura in metallo verniciato bronzo patinato / Piani cristallo stopsol bronzo  
Patinated bronze lacquered metal structure / Stopsol bronze glass

# Tortona

Massimo Castagna / 2014

Libreria in metallo verniciato bronzo patinato. Piani in cristallo 8mm stopsol bronzo o extralight temperato.  
Su richiesta disponibile top con marmo lucido naturale Calacatta Vagli Oro incassato (solo per le versioni cm 65h e cm 92h).

## NOTE TECNICHE SUI MATERIALI

**MARMO** | Il marmo è un materiale naturale di origine sedimentaria che può presentare particolarità come venature, lievi irregolarità superficiali, colorazioni differenti e cristallizzazioni. Queste peculiarità sono da attribuirsi alla naturalezza del materiale e non sono da considerarsi difetti ma caratteristiche tipiche del marmo. Ogni prodotto risulterà unico, esclusivo e non replicabile. I nostri marmi vengono trattati con un prodotto idrorepellente che permette una maggiore protezione della superficie stessa, aumentando l'impermeabilità. Questo trattamento non esclude la vulnerabilità del marmo alle sostanze acide.

**METALLO E LEGNO - BRONZO PATINATO** | Le finiture esclusive, risultato della lavorazione manuale realizzata sul metallo e sul legno, possono presentare striature e differenze cromatiche. Queste caratteristiche non devono essere considerate difetti ma elementi distintivi del processo artigianale che esaltano la bellezza e la peculiarità del pezzo unico.

Shelving system in patinated bronze lacquered metal. 8mm bronze stopsol or extralight tempered glass shelves.  
Top also available with recessed natural polished Calacatta Vagli Oro marble (only for the versions 65h cm and 92h cm, on request).

## TECHNICAL INFORMATION ON THE MATERIALS

**MARBLE** | The marble is a natural material of sedimentary origin that can present particularities such as veins, slight surface irregularities, different colors and crystallizations. These peculiarities are to be attributed to the naturalness of the material and are not to be considered defects but typical characteristics of marble. Each product will be unique, exclusive and non-replicable. Our marbles are treated with water-repellent products which affords greater protection to the surface of the marble, improving its impermeability. This treatment doesn't exclude the vulnerability of the marble to acid substances.

**METAL AND WOOD - PATINATED BRONZE** | Exclusive finishes, resulting from the craftsmanship on the metal and wood, may show streaks and chromatic differences. These characteristics should not be considered imperfections but distinctive evidence of the hand-made process that enhance the beauty and peculiarity of the unique piece.



## Cm

166 x 37 x 65  
239 x 37 x 65  
166 x 37 x 92  
239 x 37 x 92  
166 x 37 x 175  
239 x 37 x 175  
166 x 37 x 258  
239 x 37 x 258

## Inches

65½" x 14¾" x 25¾"  
94¼" x 14¾" x 25¾"  
65½" x 14¾" x 36¼"  
94¼" x 14¾" x 36¼"  
65½" x 14¾" x 69"  
94¼" x 14¾" x 69"  
65½" x 14¾" x 101¾"  
94¼" x 14¾" x 101¾"

[For technical drawing / p.469](#)

[Pricelist 2023 / p.292](#)  
[Homescapes, sense of materials / p.51](#)

## STRUTTURA/STRUCTURE



**Metallo verniciato bronzo patinato**  
Patinated bronze lacquered metal

## PIANI/SHELVES



**Cristallo stopsol bronzo**  
Stopsol bronze glass



**Cristallo extralight**  
Extralight glass

## TOP VERSIONE 65H -92H CM



**Marmo lucido naturale Calacatta Vagli Oro**  
Natural polished Calacatta Vagli Oro marble

# 09

**Librerie e boiserie /  
Shelvins system and boiserie**

**TECHNICAL MODULE**

**Brera** | Massimo Castagna, 2016

Product information / p. 430

**Versione a ripiani**  
Version with shelves

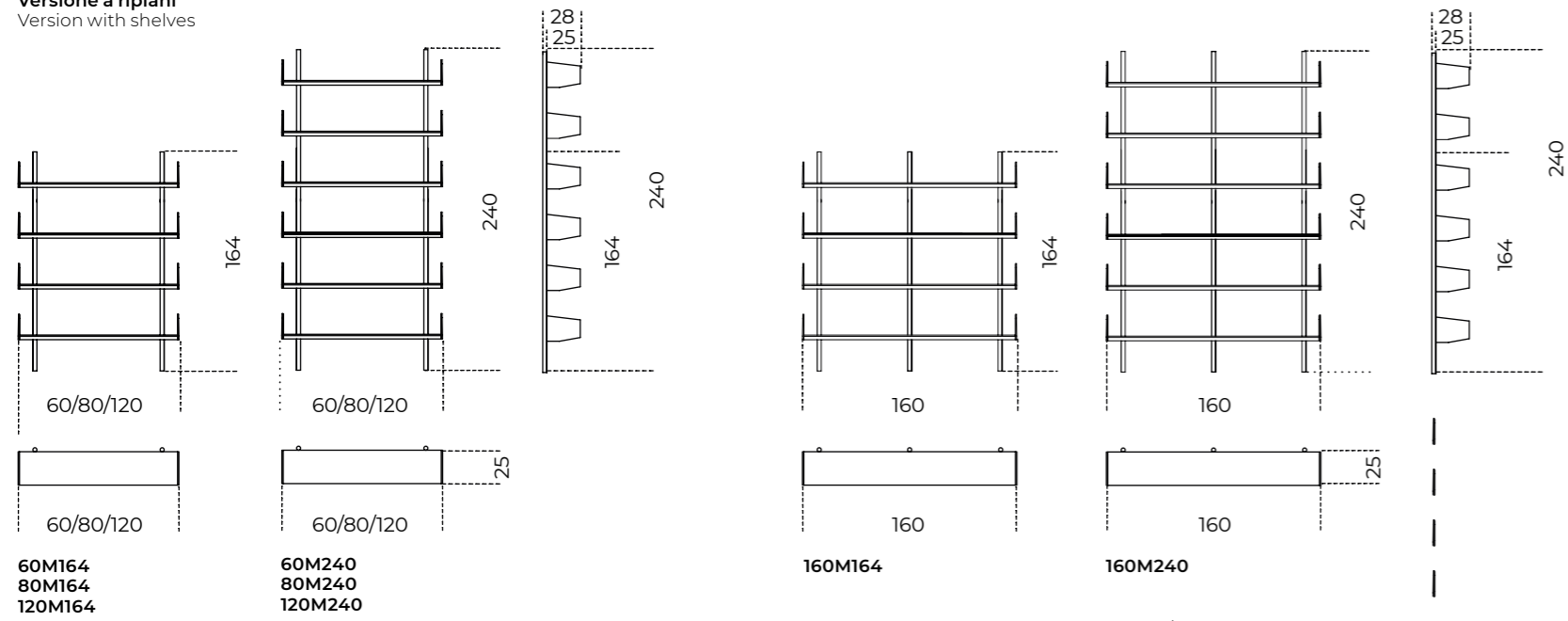

**Brera23** | Massimo Castagna, 2016

Product information / p. 432

**Versione a ripiani**  
Version with shelves

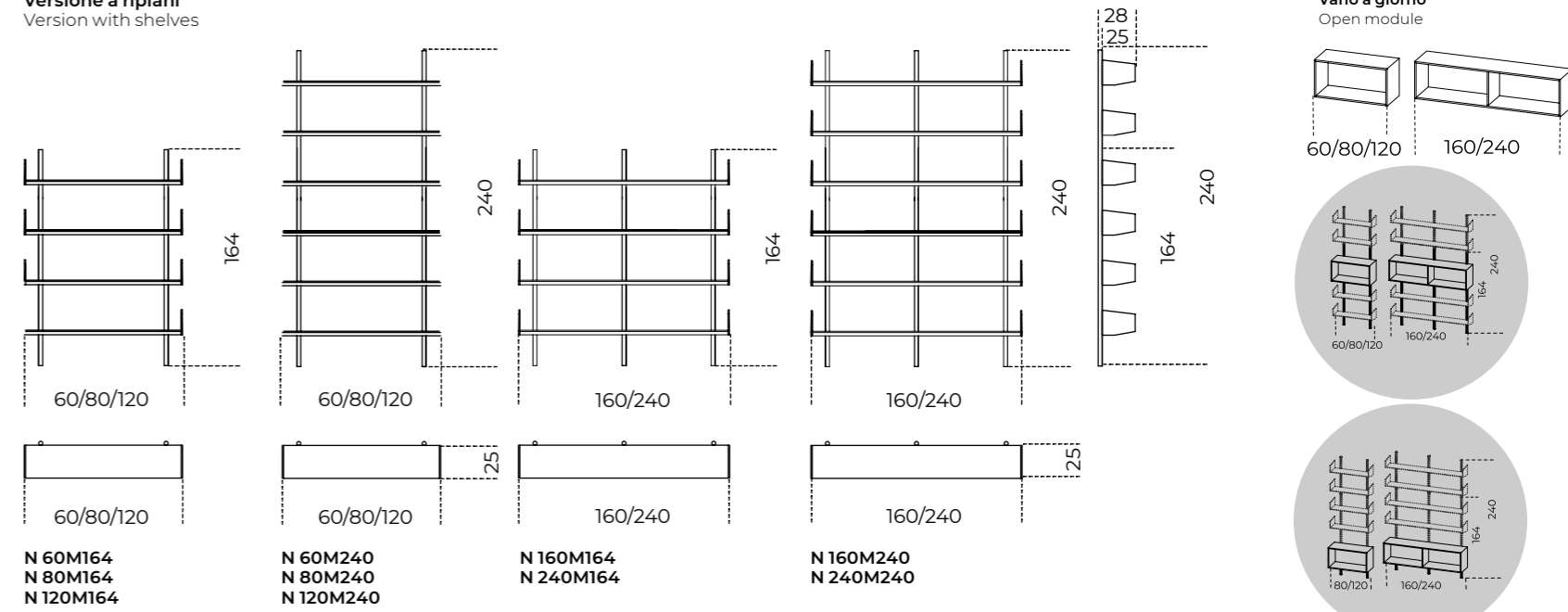

**Versione a ripiani e contenitore a ribalta**  
Version with shelves and flap door unit

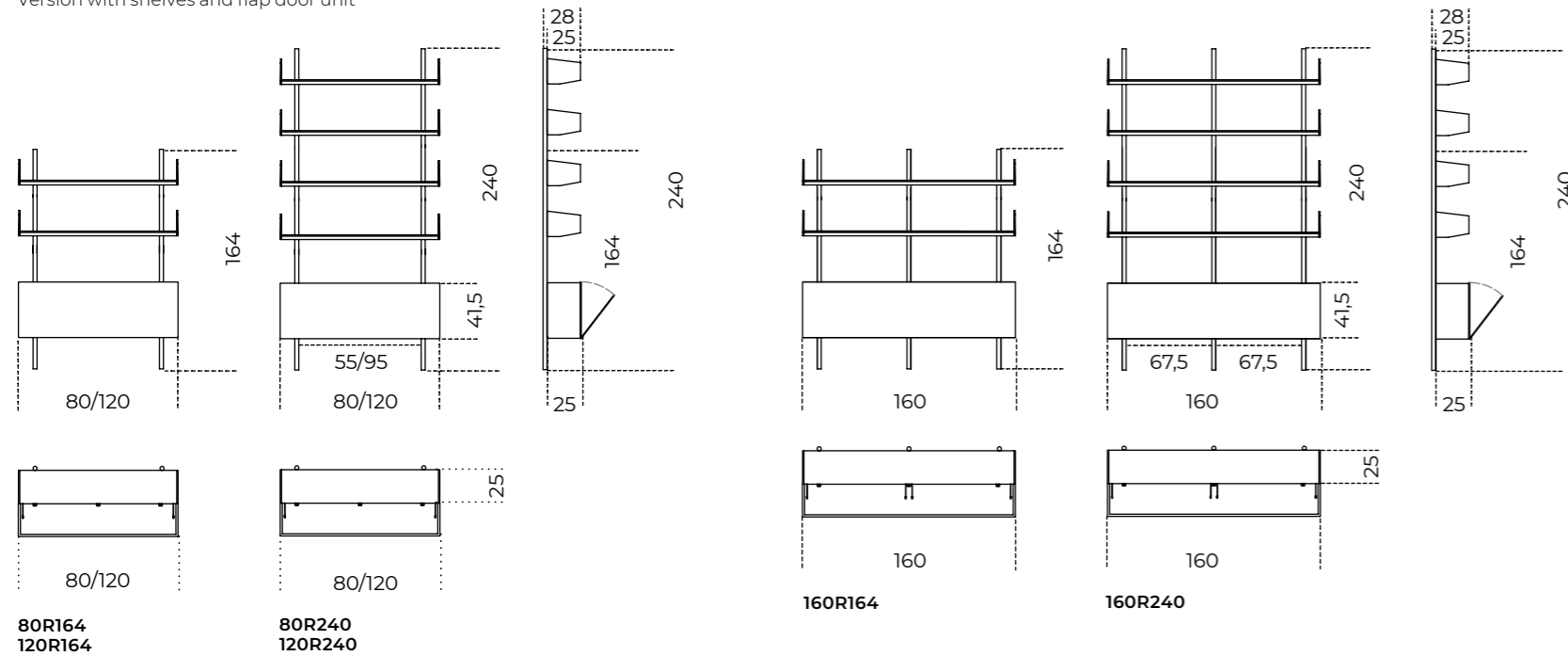

**Versione a ripiani e contenitore a ribalta**  
Version with shelves and flap door unit

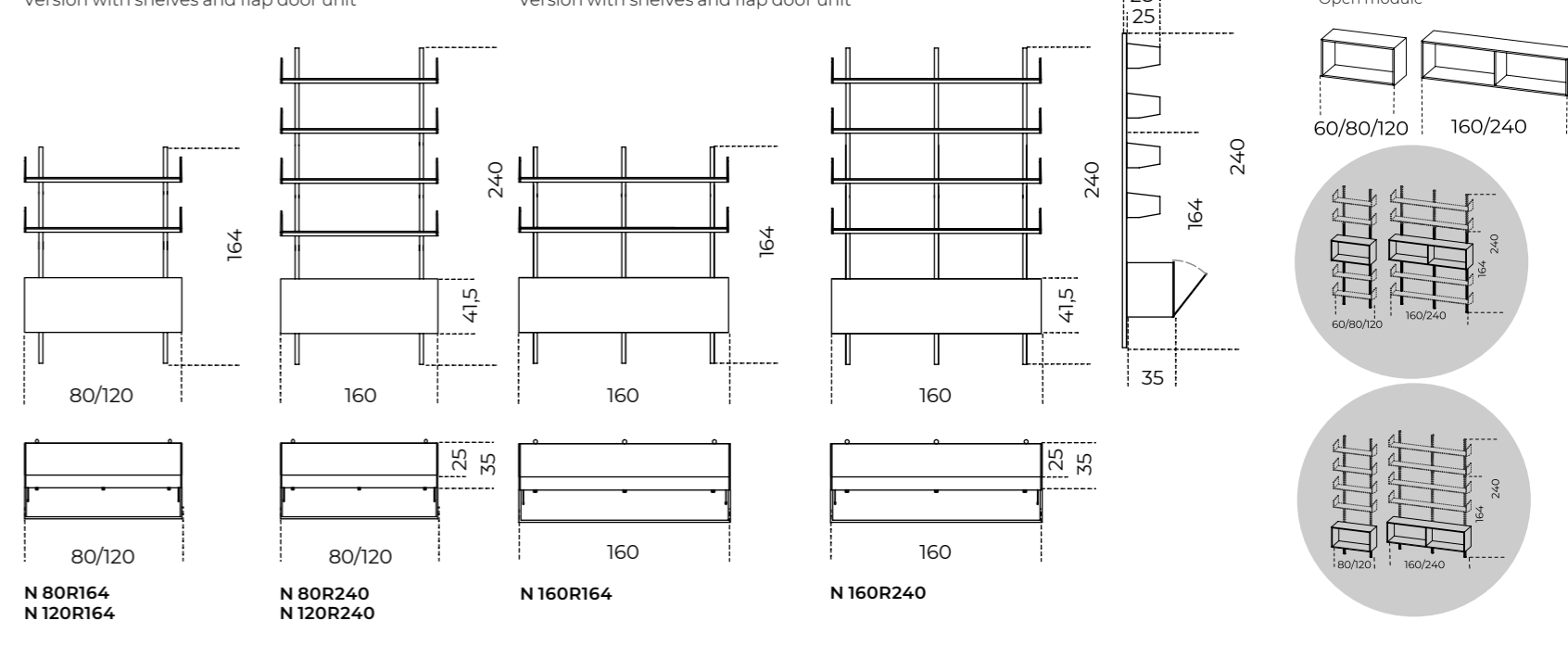

**Versione a ripiani e contenitore ad anta**  
Version with shelves and door unit

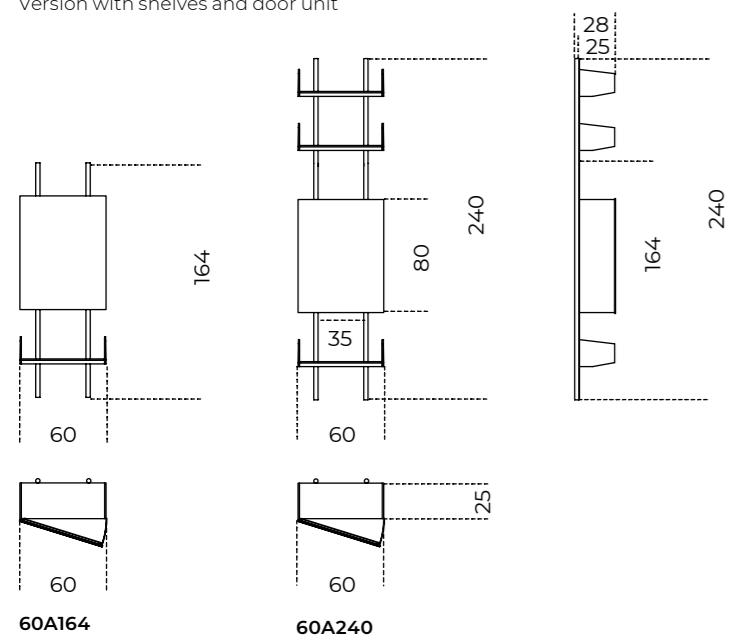

**Versione a ripiani, contenitori a ribalta e pannello tv**  
Version with shelves, flap door units and tv panel

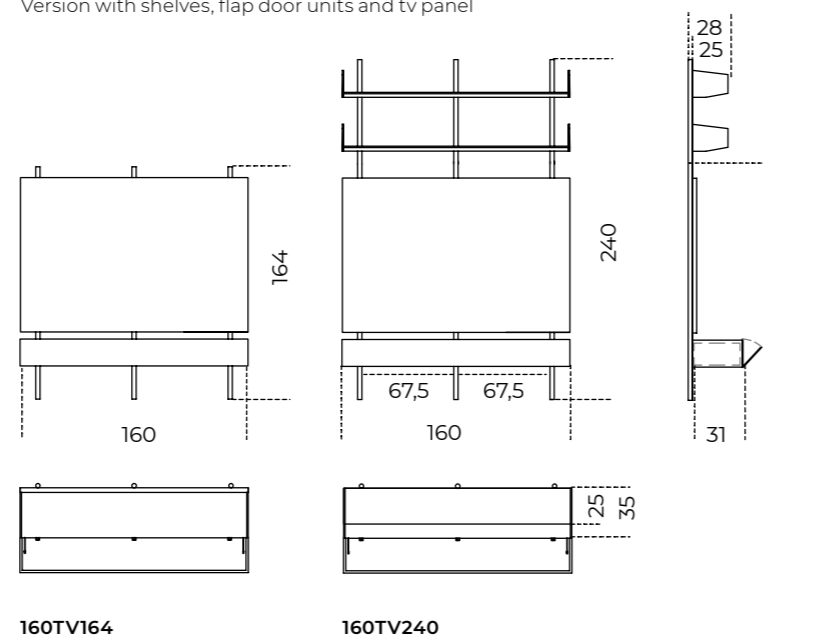

**Versione a ripiani e contenitore a ribalta**  
Version with shelves and flap door unit

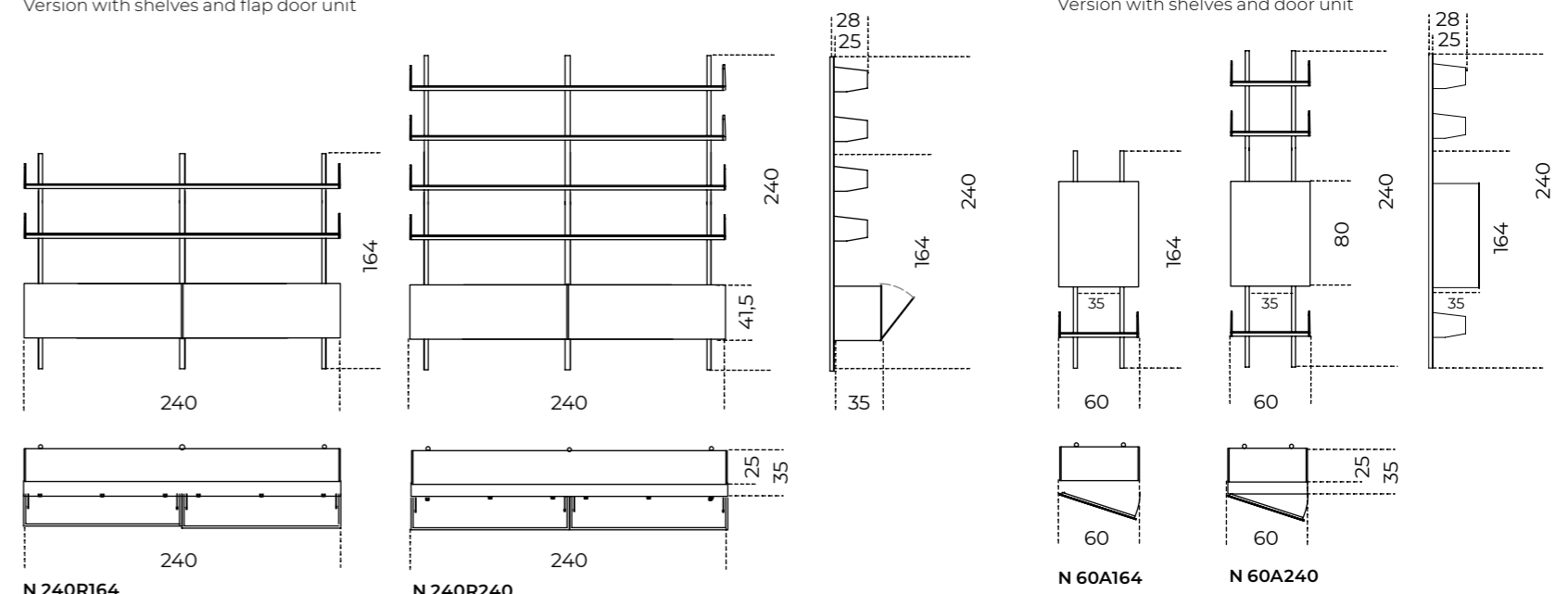

**Drizzle** | Luca Nichetto, 2012

Product information / p. 434

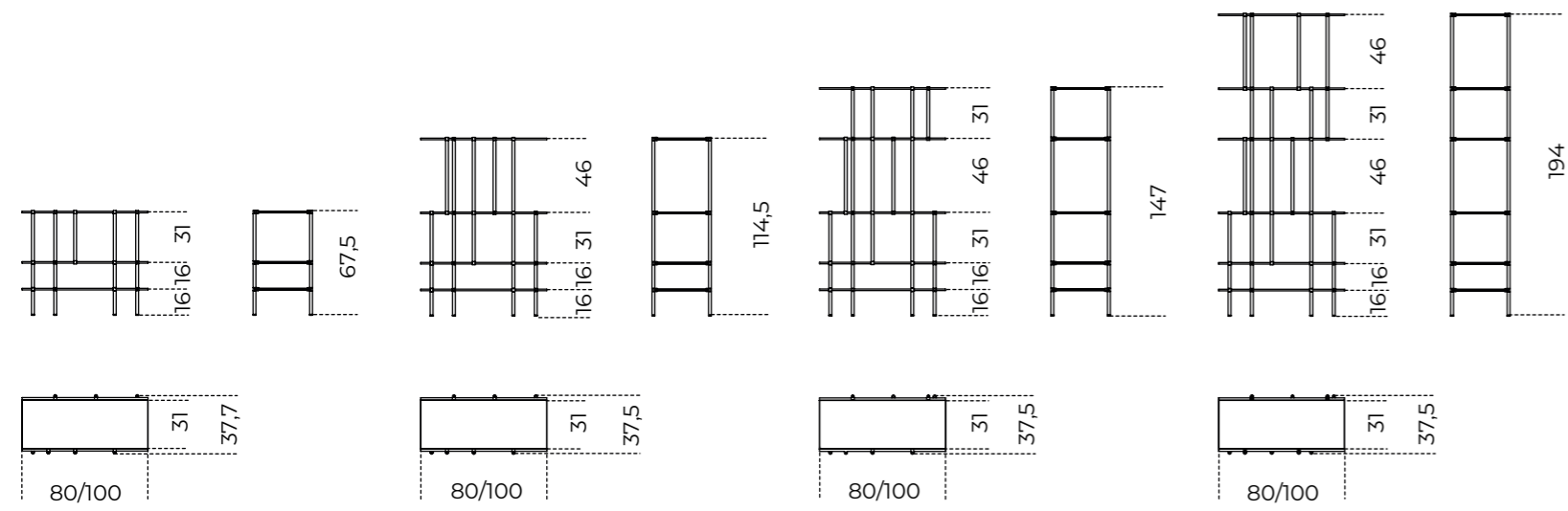

**Isola** | Massimo Castagna, 2016

Product information / p. 436

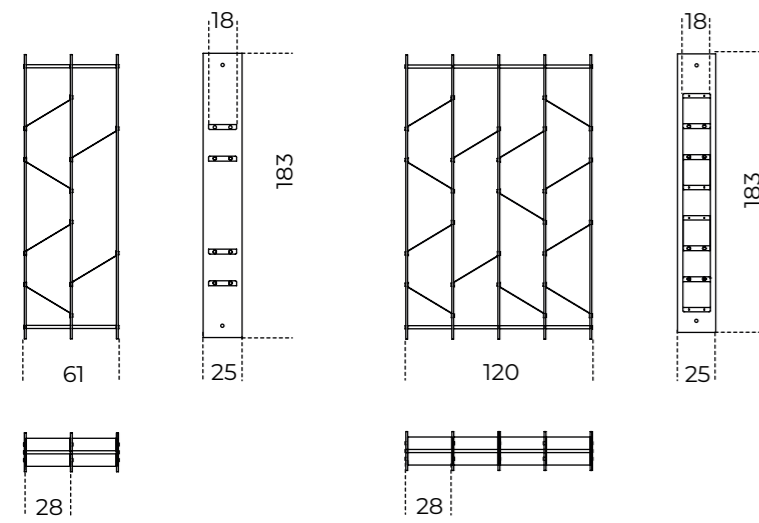

**Navigli** | Massimo Castagna, 2015

Product information / p. 440

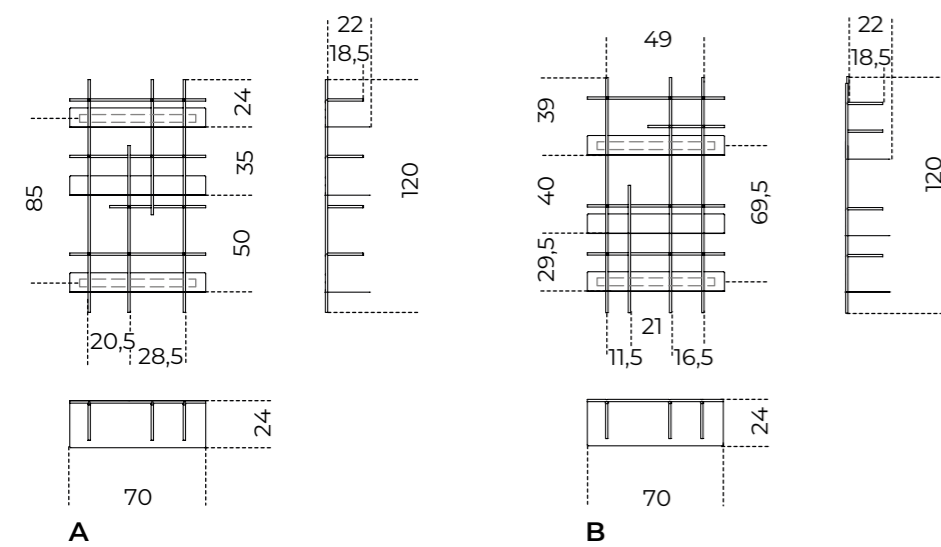

**Plejadi** | Studiopepe, 2023

Product information / p. 442

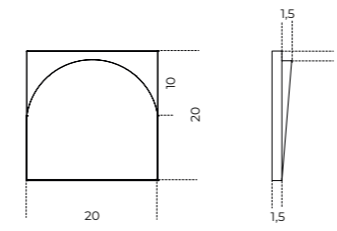

**Esempi di configurazioni**  
Configurations examples

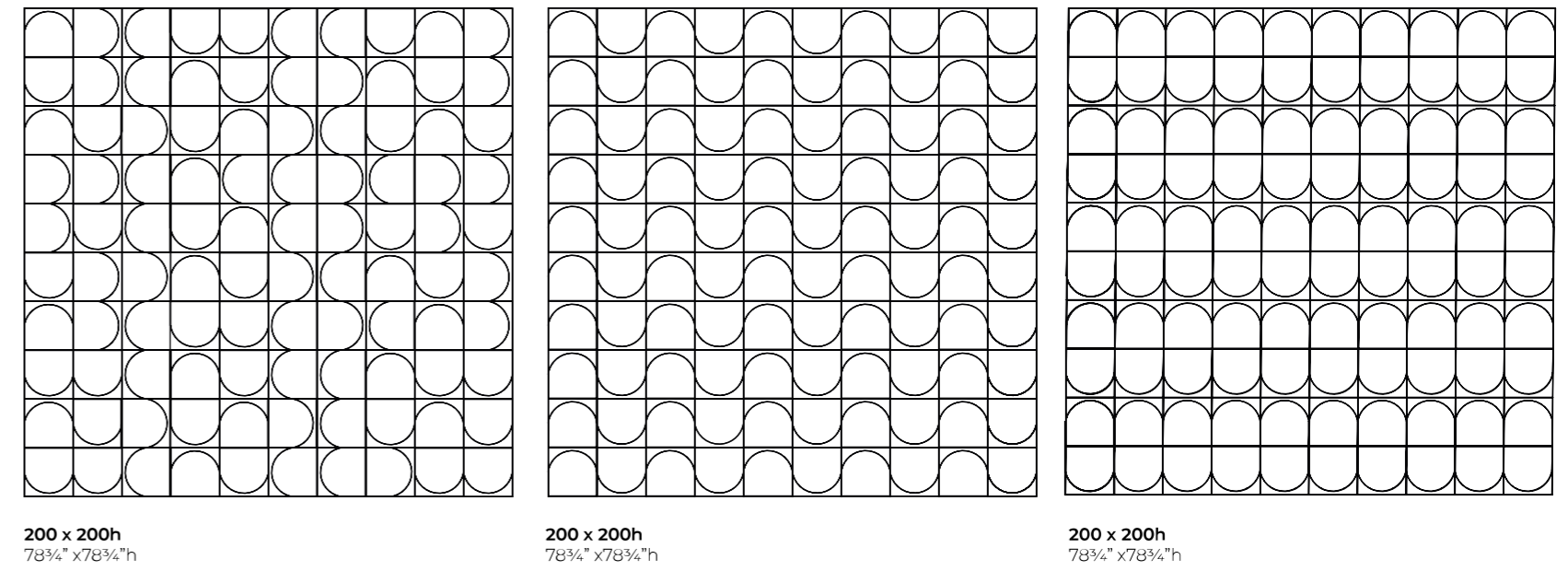

**Prism Divider** | David / Nicolas, 2021

Product information / p. 444

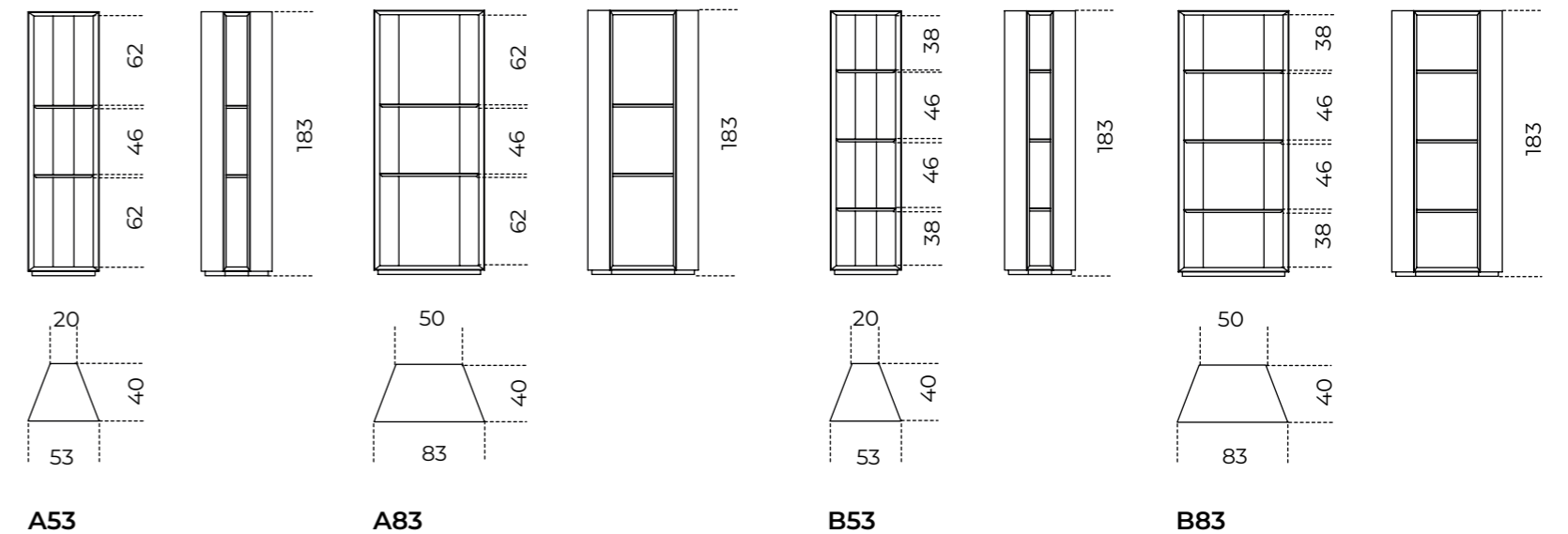

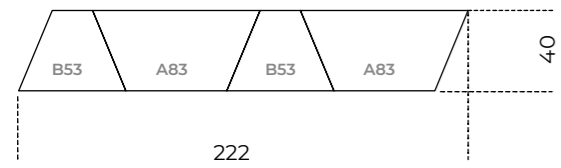
**Esempi di composizioni**  
 Composition examples

**COMPOSIZIONE 1 / COMBINAZIONE 1**  
 Composition 1 / Combination 1

 222 x 40 x 183h  
 87½" x 15¾" x 72¼"h

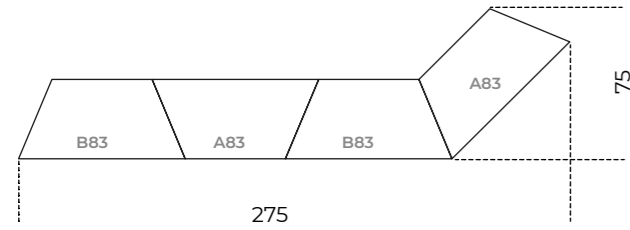
 Composta da  
 Composed by

 n. 2 A83  
 n. 2 B53

**COMPOSIZIONE 2 / COMBINAZIONE 2**  
 Composition 2 / Combination 2

 275 x 75 x 183h  
 108½" x 29¾" x 72¼"h

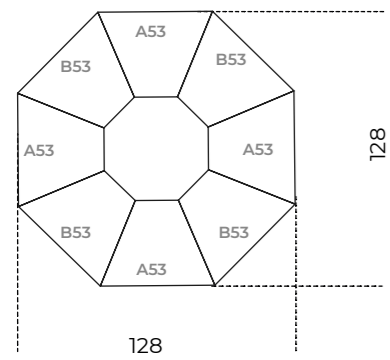
 Composta da  
 Composed by

 n. 2 A83  
 n. 2 B83

**COMPOSIZIONE 3 / COMBINAZIONE 3**  
 Composition 3 / Combination 3

 128 x 128 x 183h  
 50½" x 50½" x 72¼"h

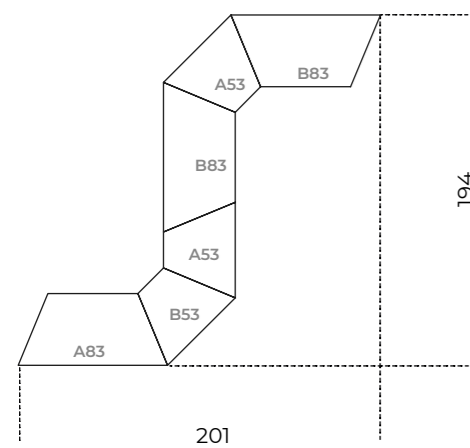
 Composta da  
 Composed by

 n. 4 A53  
 n. 4 B53

**COMPOSIZIONE 4 / COMBINAZIONE 4**  
 Composition 4 / Combination 4

 201 x 194 x 183h  
 79¾" x 76¾" x 72¼"h

 Composta da  
 Composed by

 n. 1 A83  
 n. 2 A53  
 n. 1 B53  
 n. 2 B83

Product information / p. 444

**Roundcut | Studiopepe, 2020**

Product information / p. 448

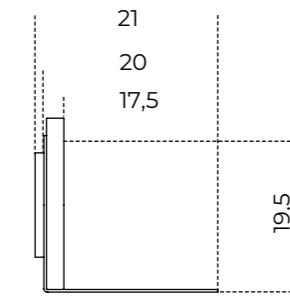
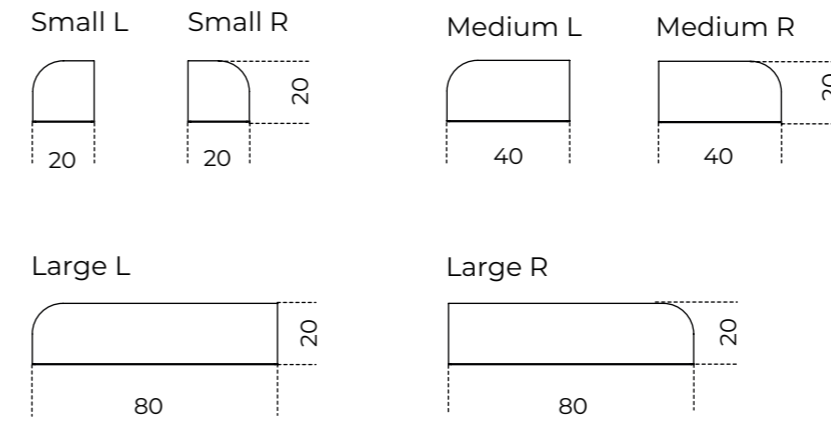
**Dettaglio vista laterale**  
 Detail side view

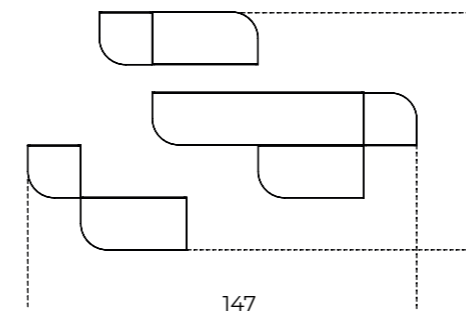
**Esempi di composizioni**  
 Composition examples

**COMPOSIZIONE 1 / COMBINAZIONE A**  
 Composition 1 / Combination A

 Composta da  
 Composed by

 n.2 Small R | Bianco Carrara Gioia  
 n.1 Small R | Verde Alpi  
 n.2 Medium R | Bianco Carrara Gioia  
 n.1 Medium R | Verde Alpi  
 n.1 Large R | Verde Alpi

**COMPOSIZIONE 1 / COMBINAZIONE B**  
 Composition 1 / Combination B

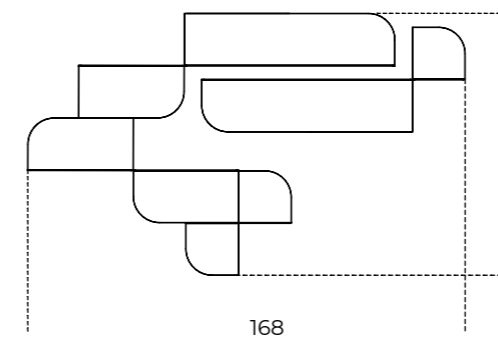
 Composta da  
 Composed by

 n.2 Small R | Travertino  
 n.1 Small R | Calacatta Vagli Oro  
 n.2 Medium R | Travertino  
 n.1 Medium R | Calacatta Vagli Oro  
 n.1 Large R | Calacatta Vagli Oro

**COMPOSIZIONE 2 / COMBINAZIONE A**  
 Composition 2 / Combination A

 Composta da  
 Composed by

 n.2 Small R | Travertino  
 n.1 Small R | Calacatta Vagli Oro  
 n.1 Medium R | Stardust grey  
 n.1 Medium L | Travertino  
 n.1 Medium L | Calacatta Vagli Oro  
 n.2 Large R | Stardust grey

**COMPOSIZIONE 2 / COMBINAZIONE B**  
 Composition 2 / Combination B

 Composta da  
 Composed by

 n.2 Small R | Bianco Carrara Gioia  
 n.1 Small R | Nero Marquinia  
 n.1 Medium R | Fior di pesco  
 n.1 Medium L | Nero Marquinia  
 n.1 Medium L | Bianco Carrara Gioia  
 n.2 Large R | Fior di pesco

**COMPOSIZIONE 2 / COMBINAZIONE C**  
 Composition 3 / Combination C

 Composta da  
 Composed by

 n.2 Small R | Bianco Carrara Gioia  
 n.1 Small R | Nero Marquinia  
 n.1 Medium R | Verde Alpi  
 n.1 Medium L | Nero Marquinia  
 n.1 Medium L | Bianco Carrara Gioia  
 n.2 Large R | Verde Alpi

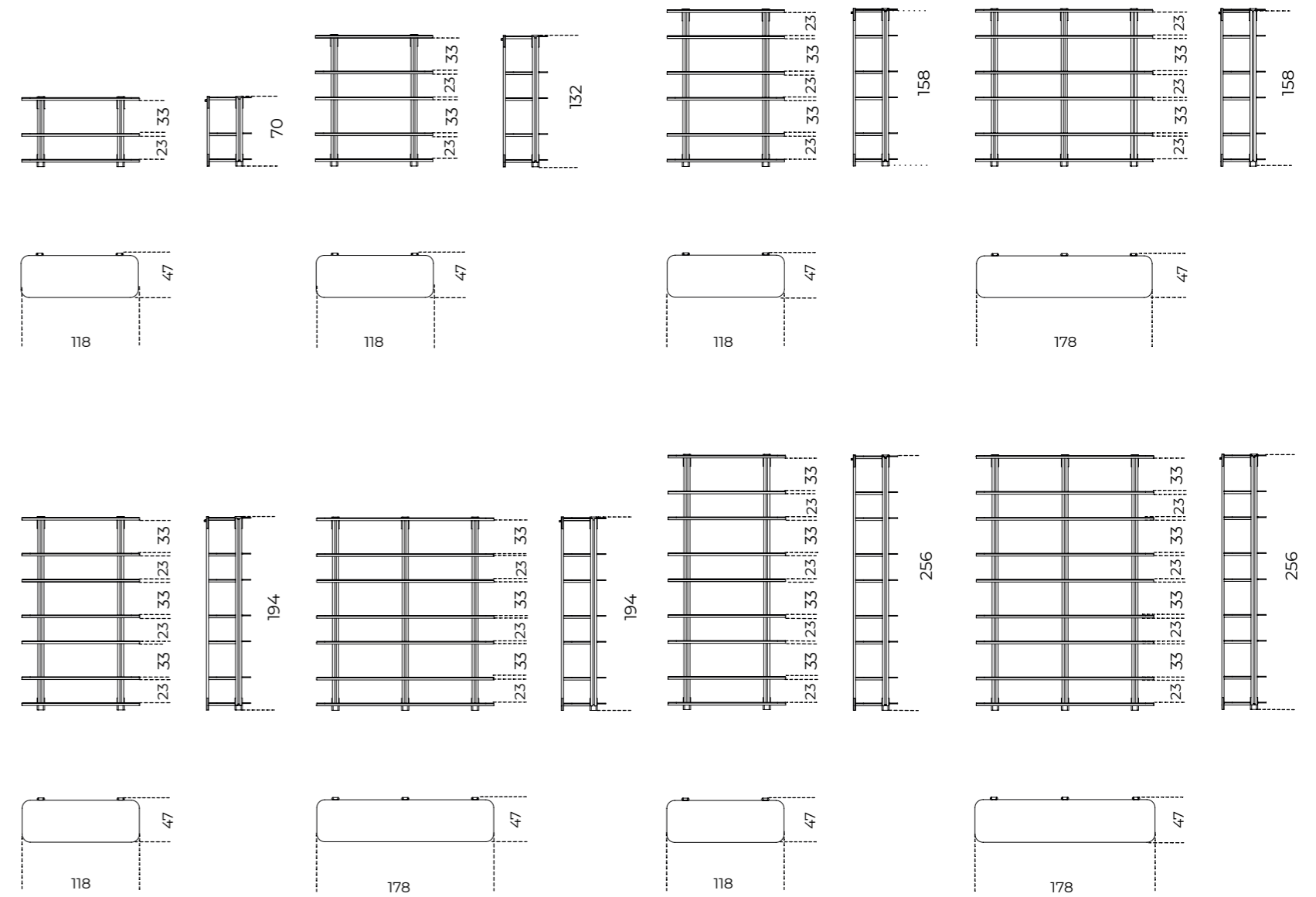
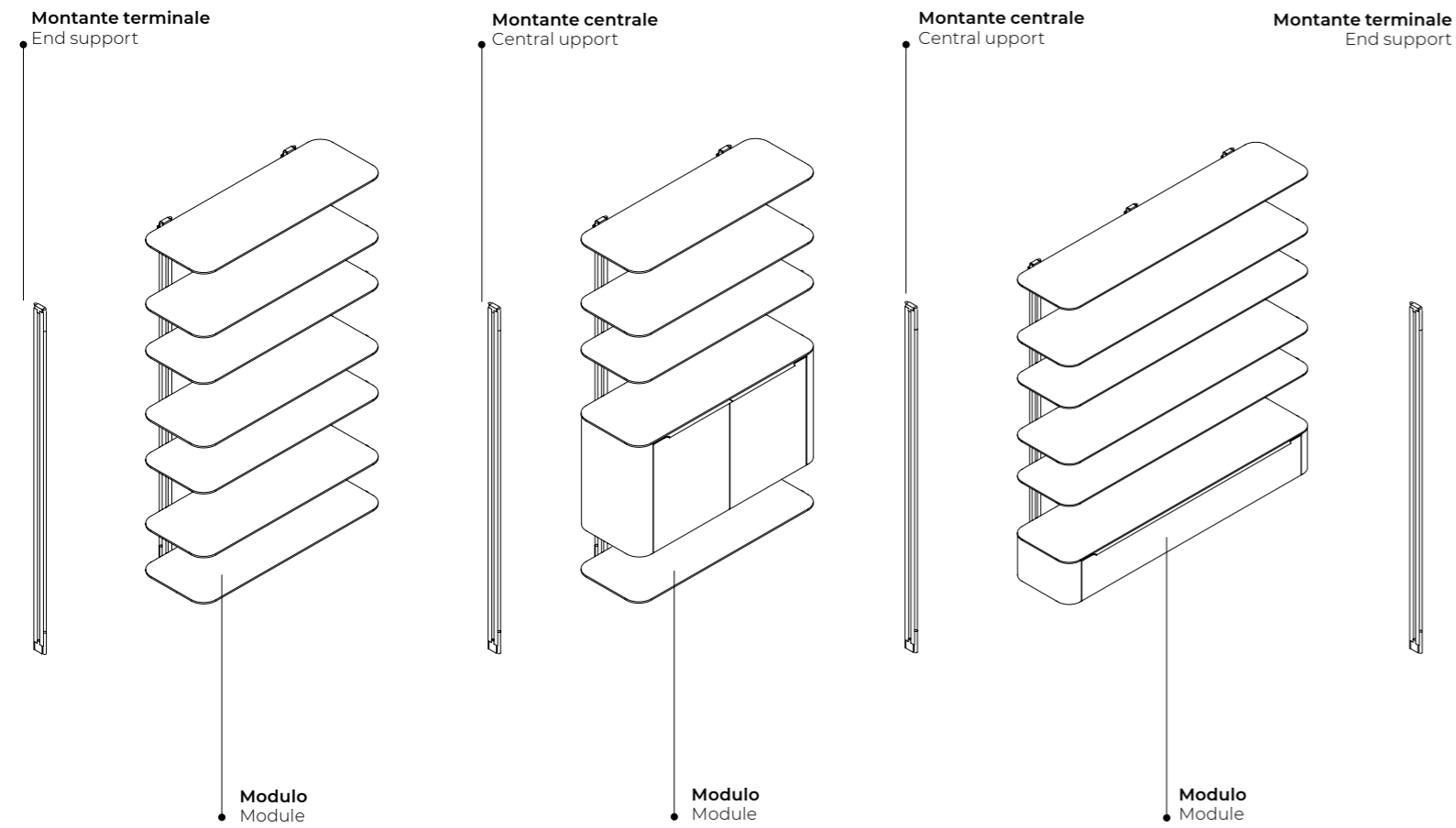

**AVVERTENZE**  
Consigliato fissaggio a parete con ferramenta inclusa.  
Viene fornito disegno per approvazione.

**WARNINGS**  
Recommended wall fixing with included hardware.  
Drawing is provided for approval.

**Esempio di composizione**  
Composition example

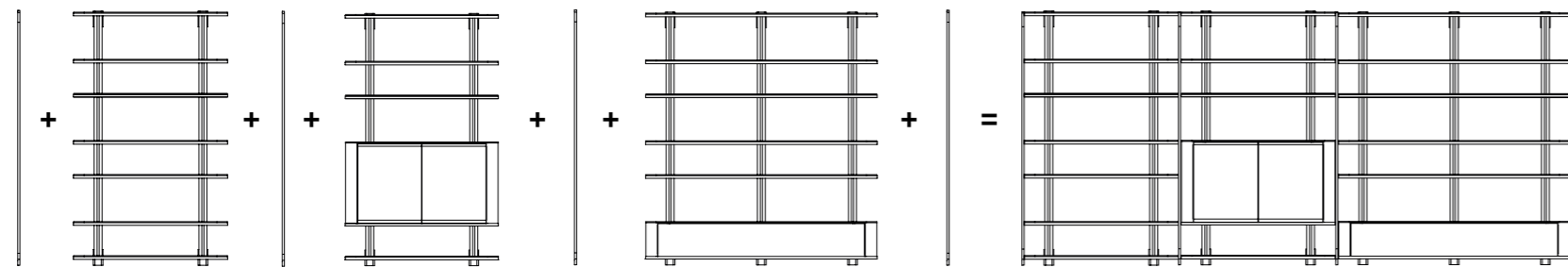



CM/INCHES

123 x 47 x 70h  
48 1/2" x 18 3/4" x 23 3/4" h

Mensole  
Shelves

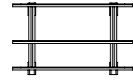

123-M-70

CM/INCHES

123 x 47 x 132h  
48 1/2" x 18 3/4" x 52" h

Mensole  
Shelves

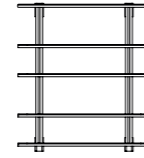

123-M-132

CM/INCHES

123 x 47 x 158h  
48 1/2" x 18 3/4" x 62 3/4" h

Mensole  
Shelves

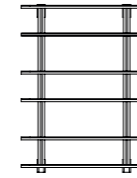

123-M-158

CM/INCHES

183 x 47 x 158h  
72 3/4" x 18 3/4" x 62 3/4" h

Mensole  
Shelves

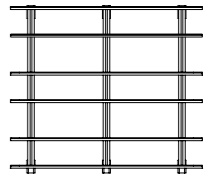

183-M-158

Mensole + cassetto  
Shelves + drawer

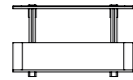

123-C1-70

Mensole + cassetto  
Shelves + drawer

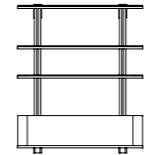

123-C1-132

Mensole + cassetto  
Shelves + drawer

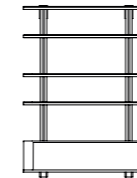

123-C1-158

Mensole + ribalta  
Shelves + flap door

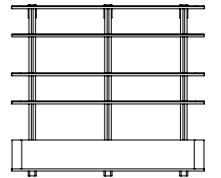

183-R1-158

Mensole + ribalta  
Shelves + flap door

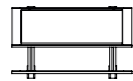

123-R2-70

Mensole + ante  
Shelves + doors

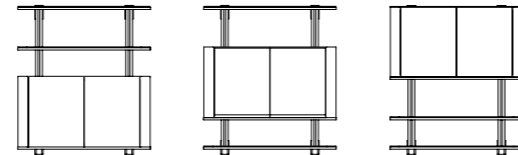

123-A1-132

123-A2-132

123-A3-132

Mensole + ante  
Shelves + doors

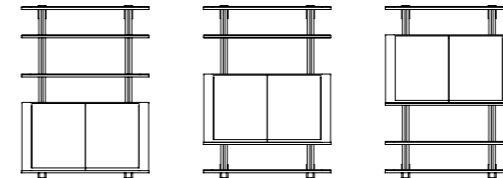

123-A1-158

123-A2-158

123-A3-158

Mensole + mobile tv  
+ ribalta  
Shelves + TV unit + flap door

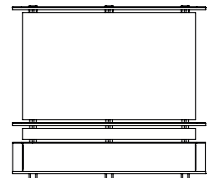

183-R1TV-158

Montante centrale  
e terminale  
Central and end support



T-70

C-70

Mensole + ribalta  
Shelves + flap door

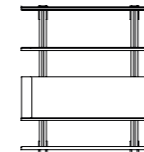

123-R2-132

Mensole + ribalta  
Shelves + flap door

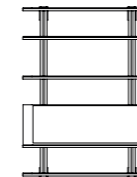

123-R2-158

Montante centrale  
e terminale  
Central and end support

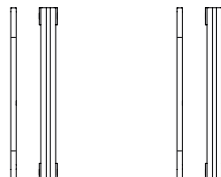

T-158

C-158

Mensole + cassetto + ante  
Shelves + drawer + doors

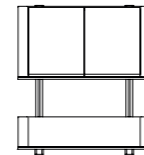

123-C1A3-132

Mensole + cassetto + ante  
Shelves + drawer + doors

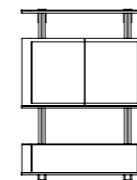

123-C1A3-158

Montante centrale  
e terminale  
Central and end support

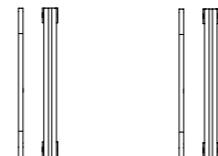

T-132

C-132

Mensole + ribalta  
Shelves + flap door

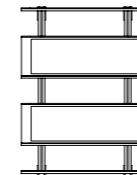

123-R2R4-158

Montante centrale  
e terminale  
Central and end support

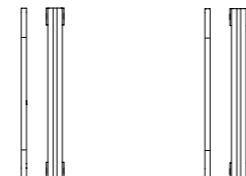

T-158

C-158

CM/INCHES

123 x 47 x 194h  
48½" x 18¾" x 76½"h

Mensole  
Shelves

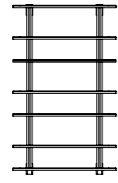

123-M-194

CM/INCHES

183 x 47 x 194h  
72¼" x 18¾" x 76½"h

Mensole  
Shelves

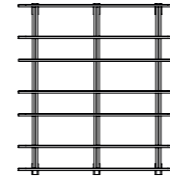

183-M-194

CM/INCHES

123 x 47 x 256h  
48½" x 18¾" x 101"h

Mensole  
Shelves



123-M-256

CM/INCHES

183 x 47 x 256h  
72¼" x 18¾" x 101"h

Mensole  
Shelves

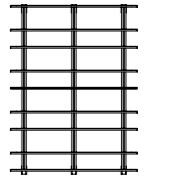

183-M-256

Mensole + cassetto  
Shelves + drawer

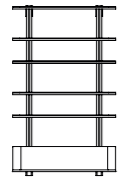

123-C1-194

Mensole + ribalta  
Shelves + flap door

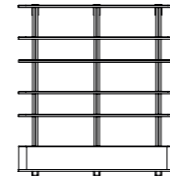

183-R1-194

Mensole + cassetto  
Shelves + drawer

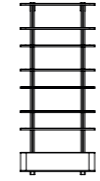

123-C1-256

Mensole + ribalta  
Shelves + flap door

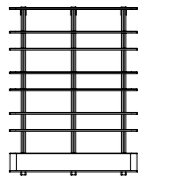

183-R1-256

Mensole + ante  
Shelves + doors



123-A1-194

123-A2-194

123-A3-194

Mensole + mobile tv  
+ ribalta  
Shelves + TV unit + flap door

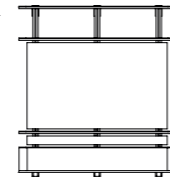

183-RITV-194

Mensole + ante  
Shelves + doors



123-A1-256

123-A2-256

123-A3-256

Mensole + mobile tv  
+ ribalta  
Shelves + TV unit + flap door

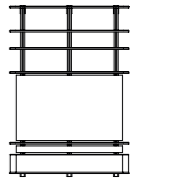

183-RITV-256

Mensole + ribalta  
Shelves + flap door

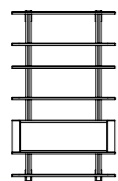

123-R2-194

Montante centrale  
e terminale  
Central and end support

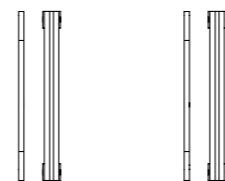

T-194

C-194

Mensole + ribalta  
Shelves + flap door



123-R2-256

Montante centrale  
e terminale  
Central and end support

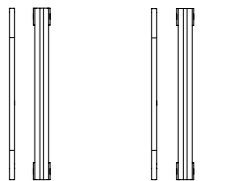

T-256

C-256

Mensole + cassetto + ante  
Shelves + drawer + doors

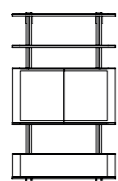

123-C1A3-194

Mensole + cassetto + ante  
Shelves + drawer + doors

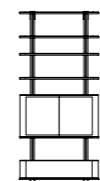

123-C1A3-256

Mensole + ribalta  
Shelves + flap door

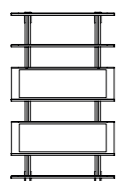

123-R2R4-194

Mensole + ribalta  
Shelves + flap door

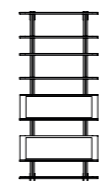

123-R2R4-256

Montante centrale  
e terminale  
Central and end support

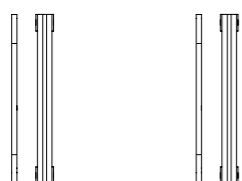

T-194

C-194

Montante centrale  
e terminale  
Central and end support

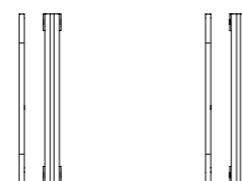

T-256

C-256

COMPOSIZIONI  
COMPOSITIONS

COMPOSITION 1

363 x 47 x 70h  
143" x 18¾" x 23¾h

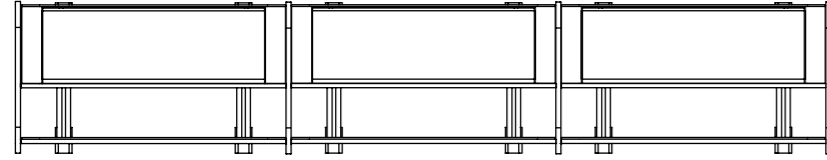

Composta da  
Composed by

n. 3 123-R2-70  
n. 2 C-70  
n. 2 T-70

COMPOSITION 2

243 x 47 x 132h  
95¾" x 18¾" x 76½h

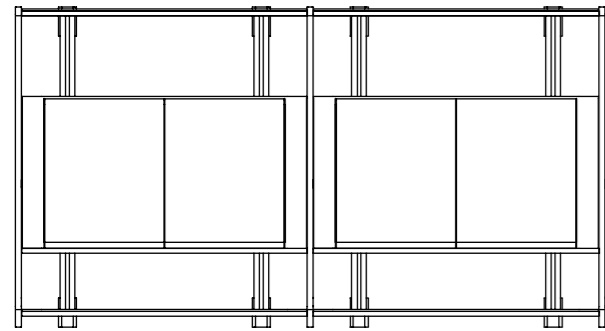

Composta da  
Composed by

n. 2 123-A2-132  
n. 1 C-132  
n. 2 T-132

COMPOSITION 3

303 x 47 x 194h  
119½" x 18¾" x 76½h

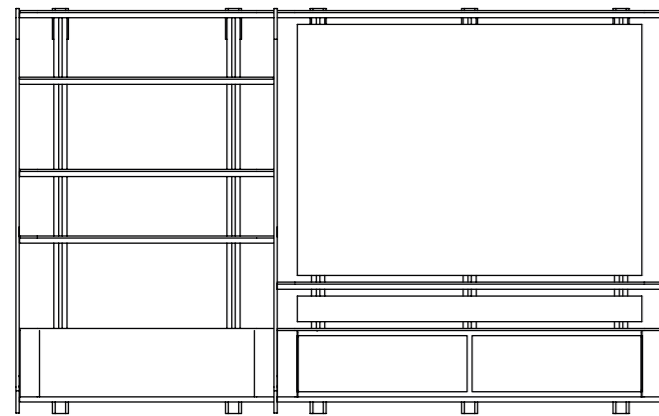

Composta da  
Composed by

n. 1 123-C1-194  
n. 1 183-R1TV-194  
n. 1 C-194  
n. 2 T-194

Tortona | Massimo Castagna, 2014

Product information / p. 452

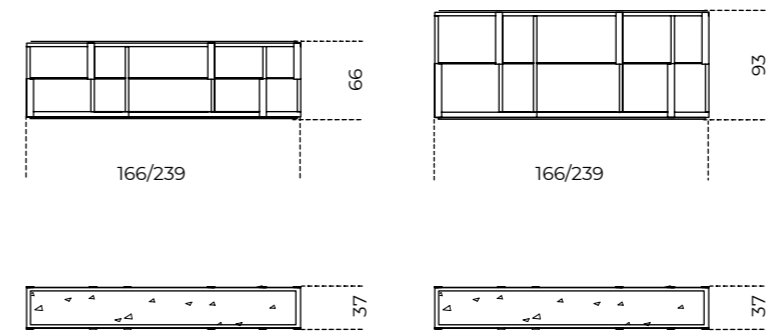
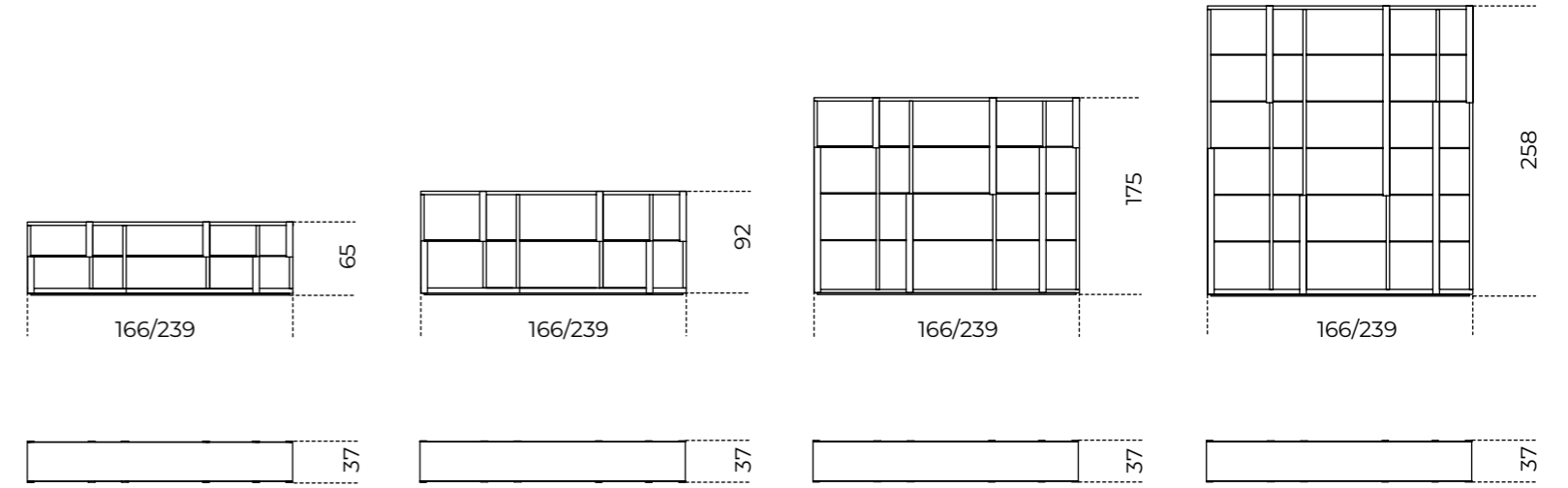

Piano in marmo  
Marble top

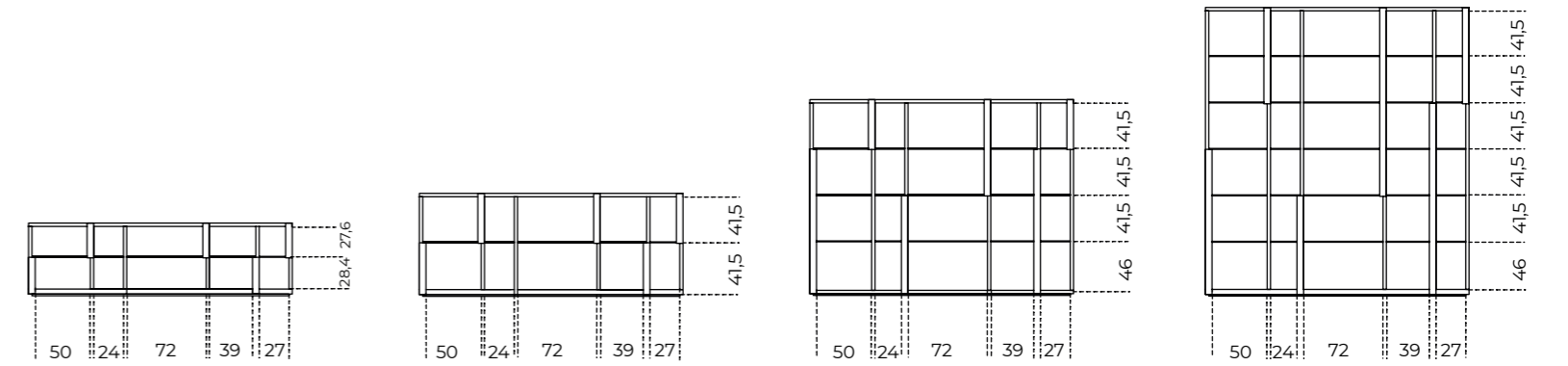

## **10 Letti /** Beds

472 **Eve**  
474 **Lilas Bed**  
476 **Sunrise**  
478 **Xeni**  
480 **Yuki**

482 **Informazioni tecniche/**  
[Technical informations](#)

# Eve

Pietro Russo / 2021

Letto con testata boiserie in legno Noce "Colore" Frisé intarsiato a spina di pesce con pannelli laterali orientabili. Giroletto sfoderabile imbottito in poliuretano espanso indeformabile a densità differenziate e fibra poliestere rivestito in nabuk o velluto nei colori del campionario. Rete a doghe inclusa. Disponibile versione con comodini con luce integrata a LED in legno e metallo verniciati nero opaco dotati di cassetto con apertura rotante a 90°. Luce LED attivata da un sensore a movimento.

! Giroletto sfoderabile, non fissato alla testata.

La testata deve essere fissata al muro con staffe e ganci regolabili forniti in dotazione. Il fissaggio a parete possibile solo ed esclusivamente in presenza di muri di mattone forato o calcestruzzo. Non possibile in caso di muri di cartongesso.

Il legno è un materiale vivo che subisce un naturale processo di ossidazione che può causare cambiamenti cromatici. Venature e tonalità di colore differenti delle lastre non sono da considerarsi come difetti, ma caratteristiche che esaltano l'unicità del materiale.

## NOTE TECNICHE SUI MATERIALI

**INTARSIO** | L'intarsio è una tecnica di lavorazione artigianale utilizzata per ottenere un particolare disegno e si realizza accostando elementi di materiali differenti (come legno e alluminio) oppure dello stesso materiale. Questa lavorazione rende il prodotto unico ed esclusivo. Le eventuali variazioni cromatiche e di venatura del legno sono da considerarsi caratteristiche del materiale stesso e non possono essere controllate.

Bed with boiserie headboard in "Colore" Frisé walnut herringbone wood inlay with adjustable side panels. Bedframe in non-deformable foam polyurethan in different density and polyester fiber with removable cover in nabuk or velvet as per samples. Wooden slats included. Available version with matt black painted wooden and metal bedside tables with integrated Led light, equipped with drawer with 90° rotating opening. Led light turned on by a motion sensor.

! Bed frame, not fixed to the headboard, with removable cover.

The headboard is fastened to the wall through provided adjustable wall brackets and hooks. The fixing against the wall is possible only with solid walls. It is not possible with plasterboards.

Wood is a living material and the natural oxidation process can cause chromatic changes. Different grain and colour shades of the wooden slabs are not to be considered as defects, but characteristics that enhance the uniqueness of the material.

## TECHNICAL INFORMATION ON THE MATERIALS

**INLAY** | Inlay is an artisanal technique used to obtain a particular design and is made by combining elements of different materials (such as wood and aluminium) or of the same material. This process makes the product unique and exclusive. Any colour and grain variations of the wood are to be considered as characteristics of the material itself and cannot be controlled.



### Cm

300 x 211,5 x 141 (160 x 200)\*

330 x 211,5 x 141 (180 x 200)\*

360 x 211,5 x 141 (200 x 200)\*

300 x 214,5 x 141 (153 x 203)\*

360 x 214,5 x 141 (193 x 203)\*

330 x 224,5 x 141 (183 x 213)\*

### Inches

118 1/4" x 83 1/4" x 55 3/4" (63" x 78 3/4")\*

130" x 83 1/4" x 55 3/4" (71" x 78 3/4")\*

141 3/4" x 83 1/4" x 55 3/4" (78 3/4" x 78 3/4")\*

118 1/4" x 84 1/2" x 55 3/4" (60 1/4" x 80")\*

141 3/4" x 84 1/2" x 55 3/4" (76" x 80")\*

130" x 88 1/2" x 55 3/4" (72 1/4" x 84")\*

\* Materasso (L x P)

\*Mattress (W x D)

[For technical drawing / p. 486](#)

Pricelist 2023 / p. 302  
Homescapes, intimate portraits/ p. 65, 102  
Homescapes, gentle attitude / pp. 52, 55

## TESTATA/HEADBOARD

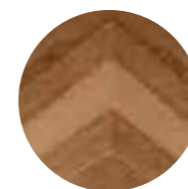

Legno noce "Colore" Frisé  
"Colore" Frisé Walnut wood

## RIVESTIMENTO/COVER



Nabuk/velluto nei colori  
del campionario  
Nabuk/velvet as per  
samples.

## COMODINI/BEDSIDE TABLE

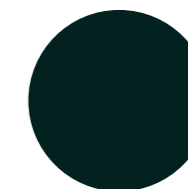

Legno e metallo verniciati  
nero opaco  
Matt black painted wooden  
and metal

# Lilas Bed

Dainelli Studio / 2022

Letto in poliuretano espanso indeformabile a densità differenziate e fibra poliestere con struttura interna in legno. Disponibile con rivestimento sfoderabile in tessuto o pelle nei colori del campionario. Rete a doghe inclusa.

Bed in non-deformable foam polyurethane in different density and polyester fibre with wooden inside structure. Available with removable cover in fabric or leather as per sample. Wooden slats included.

**! Rivestimento sfoderabile.**

Per la realizzazione di elementi con rivestimento in pelle sono necessarie cuciture aggiuntive rispetto gli elementi con rivestimento in tessuto.

**! Removable cover for bed frame.**

Additional stitching is required for elements with leather upholstery compared to elements with fabric upholstery.



**Cm**

177 x 217 x 85 (160 x 200)\*  
197 x 217 x 85 (180 x 200)\*  
217 x 217 x 85 (200 x 200)\*  
177 x 217 x 85 (153 x 203)\*  
217 x 217 x 85 (193 x 203)\*  
197 x 227 x 85 (183 x 213)\*

Cuscini a rullo

18 x 75 (160 x 200)\*  
18 x 85 (180 x 200)\*  
18 x 95 (200 x 200)\*  
18 x 71 (153 x 203)\*  
18 x 95 (193 x 203)\*  
18 x 86 (183 x 213)\*

\* Materasso (L x P)

**Inches**

69 $\frac{3}{4}$ " x 85 $\frac{1}{2}$ " x 33 $\frac{1}{2}$ " (63" x 78 $\frac{3}{4}$ ")\*  
77 $\frac{3}{4}$ " x 85 $\frac{1}{2}$ " x 33 $\frac{1}{2}$ " (71" x 78 $\frac{3}{4}$ ")\*  
85 $\frac{1}{2}$ " x 85 $\frac{1}{2}$ " x 33 $\frac{1}{2}$ " (78 $\frac{3}{4}$ " x 78 $\frac{3}{4}$ ")\*  
69 $\frac{3}{4}$ " x 85 $\frac{1}{2}$ " x 33 $\frac{1}{2}$ " (60 $\frac{1}{4}$ " x 80")\*  
85 $\frac{1}{2}$ " x 85 $\frac{1}{2}$ " x 33 $\frac{1}{2}$ " (76" x 80")\*  
77 $\frac{3}{4}$ " x 89 $\frac{1}{2}$ " x 33 $\frac{1}{2}$ " (72 $\frac{1}{4}$ " x 84")\*

Rollcushions

7 $\frac{1}{4}$ " x 29 $\frac{3}{4}$ " (63" x 78 $\frac{3}{4}$ ")\*  
7 $\frac{1}{4}$ " x 33 $\frac{1}{2}$ " (71" x 78 $\frac{3}{4}$ ")\*  
7 $\frac{1}{4}$ " x 37 $\frac{1}{2}$ " (78 $\frac{3}{4}$ " x 78 $\frac{3}{4}$ ")\*  
7 $\frac{1}{4}$ " x 28" (60 $\frac{1}{4}$ " x 80")\*  
7 $\frac{1}{4}$ " x 37 $\frac{1}{2}$ " (76" x 80")\*  
7 $\frac{1}{4}$ " x 34" (72 $\frac{1}{4}$ " x 84")\*

\*Mattress (W x D)

[For technical drawing / p. 486](#)

[Pricelist 2023 / p. 304](#)  
[Homescapes, gentle attitude / pp. 98, 101](#)

**RIVESTIMENTO/COVER**



Tessuto/pelle nei colori del campionario  
Fabric/leather as per samples.

\* LILAS BED  
Rivestimento in Bloom silver 029.  
Cover in Bloom silver 029.

# Sunrise

Studiopepe / 2024

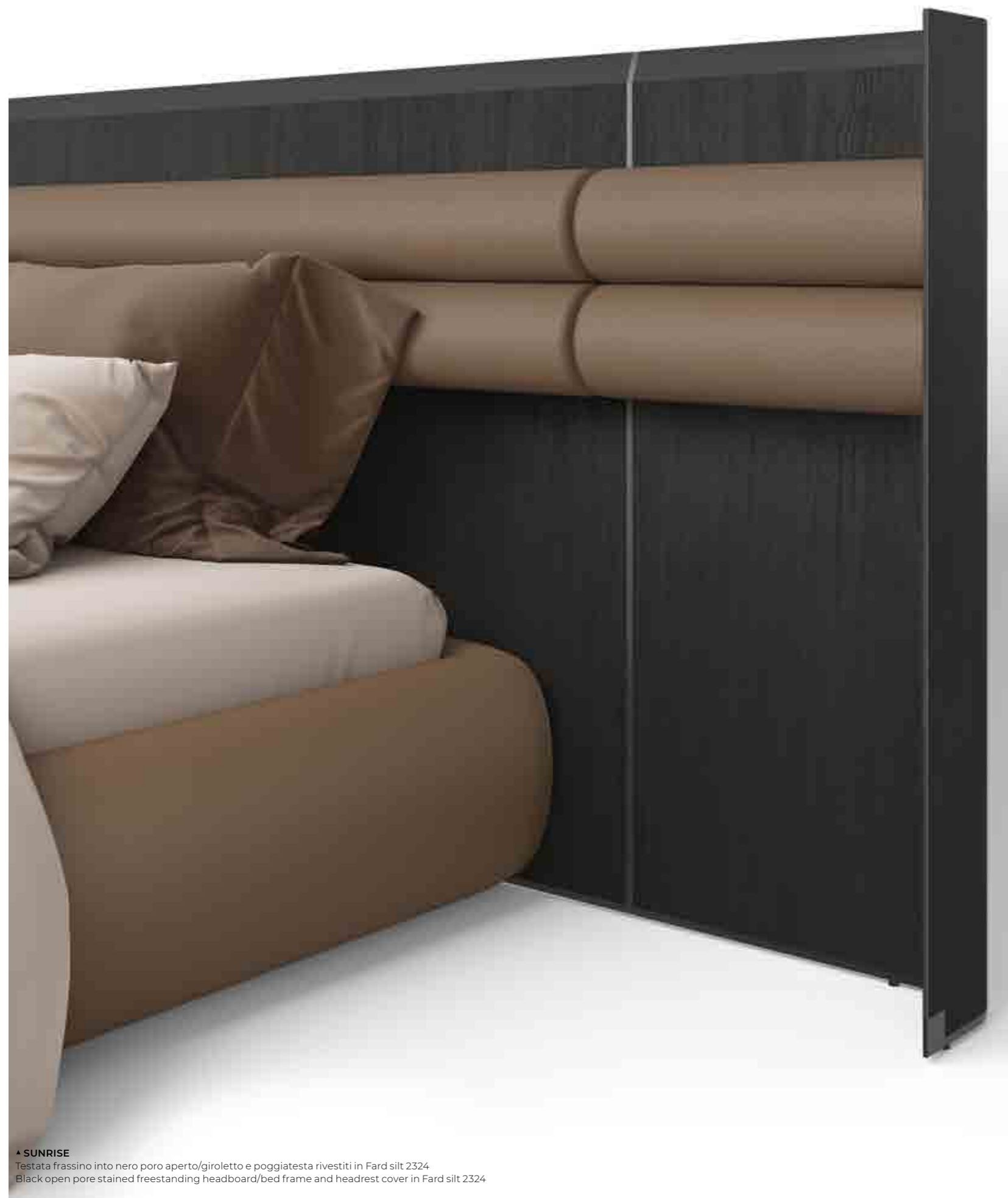

Letto con testata autoportante in legno curvato. Disponibile nelle seguenti finiture: frassino tinto nero a poro aperto oppure legno laccato opaco nei colori "Bianco Camargue", "Sabbia del Nilo", "Rosa Jaipur", "Rosso Persia", "Bordeaux Etruria", "Verde Provenza", "Blu Pacifico", "Grigio Londra", "Nero Giza".  
 Dettagli in metallo laccato in abbinamento al colore della testata. Su richiesta in metallo nickelato nero lucido.  
 Poggiatesta e giroletto imbottiti in poliuretano espanso indeformabile a densità differenziate e fibra di poliestere. Rivestimento in tessuto o pelle, nei colori di campionario. Rete a doghe inclusa.

Bed with curved freestanding wooden headboard. Available in the following finishes: black open pore stained ash or opaque lacquered wood in the colours "Bianco Camargue", "Sabbia del Nilo", "Rosa Jaipur", "Rosso Persia", "Bordeaux Etruria", "Verde Provenza", "Blu Pacifico", "Grigio Londra", "Nero Giza". Lacquered metal details matching the colour of the headboard.  
 On request bright black nickel-plated metal details.  
 Headrest and bed frame in non-deformable foam polyurethane in different density and polyester fibre covered by fabric or leather as per samples.  
 Wooden slats included.

! Giroletto sfoderabile.  
 Poggiatesta sfoderabili in tessuto.  
 Non sfoderabili nelle seguenti categorie: Cat. L1, L2 e pelle cliente/C.O.L.

! Removable bed frame.  
 Removable headrests.  
 Not available for the following categories: Cat. L1, L2 and customer leather C.O.L.

Per la realizzazione di elementi con rivestimento in pelle sono necessarie cuciture aggiuntive rispetto gli elementi con rivestimento in tessuto.

Additional stitching is required for elements with leather upholstery compared to elements with fabric upholstery.

La testata è fissata al giroletto tramite un sistema di aggancio meccanico.

The headboard is fastened to the bed frame through a mechanic system.



Cm	Inches
300 x 223 x 108 (160 x 200)*	118¼" x 88" x 43¾" (63 x 78¾)
320 x 223 x 108 (180 x 200)*	126" x 88" x 43¾" (71 x 78¾)*
340 x 223 x 108 (200 x 200)*	134" x 88" x 43¾" (78 x 78¾)*
300 x 223 x 108 (153 x 203)*	118¼" x 88" x 43¾" (60¼ x 80)*
320 x 223 x 108 (183 x 213)*	126" x 88" x 53¾" (72¼ x 84)*
340 x 223 x 108 (193 x 203)*	134" x 88" x 43¾" (76 x 80)*

\* Materasso (L x P)

\* Mattress (W x D)

For technical drawing / p. 487

Pricelist 2023 / p. 302  
 Homescapes, intimate portraits / p. 65, 102  
 Homescapes, gentle attitude / pp. 52, 55

## BASE/BASE

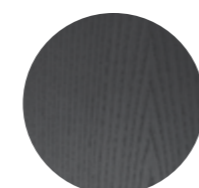

Frassino curvato tinto nero poro aperto  
 Curved black open pore stained ash



Laccato opaco "Bianco Camargue"  
 Opaque lacquered "Bianco Camargue"



Laccato opaco "Sabbia del Nilo"  
 Opaque lacquered "Sabbia del Nilo"

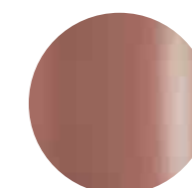

Laccato opaco "Rosa Jaipur"  
 Opaque lacquered "Rosa Jaipur"

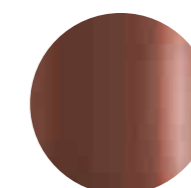

Laccato opaco "Rosso Persia"  
 Opaque lacquered "Rosso Persia"

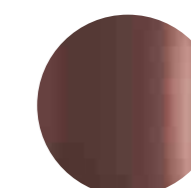

Laccato opaco "Bordeaux Etruria"  
 Opaque lacquered "Bordeaux Etruria"

## RIVESTIMENTO/COVER

## DETTAGLI/DETAILS

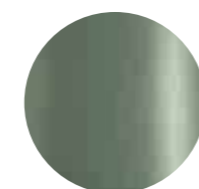

Laccato opaco "Verde Provenza"  
 Opaque lacquered "Verde Provenza"

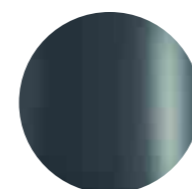

Laccato opaco "Blu Pacifico"  
 Opaque lacquered "Blu Pacifico"



Laccato opaco "Grigio Londra"  
 Opaque lacquered "Grigio Londra"



Laccato opaco "Nero Giza"  
 Opaque lacquered "Nero Giza"



Tessuto/pelle nei colori del campionario  
 Fabric as per samples.



Metallo nickelato nero  
 Black nickel-plated metal

▲ SUNRISE  
 Testata frassino into nero poro aperto/giroletto e poggiatesta rivestiti in Fard silt 2324  
 Black open pore stained freestanding headboard/bed frame and headrest cover in Fard silt 2324

# Xeni

Massimo Castagna / 2018

Letto in poliuretano espanso indeformabile a densità differenziate e fibra poliestere con struttura interna in legno. Disponibile con rivestimento in tessuto o pelle nei colori di campionario. Rete a doghe inclusa.

Bed in non-deformable foam polyurethane in different density and polyester fibre with wooden inside structure. Available covered by fabric or leather as per sample. Wooden slats included.

**!** Giroletto sfoderabile.

La testata è fissata al giroletto tramite un pratico sistema di aggancio a baionetta.

Per la realizzazione di elementi con rivestimento in pelle sono necessarie cuciture aggiuntive rispetto gli elementi con rivestimento in tessuto.

**!** Removable cover for bed frame.

The headboard is fastened to the bed frame through a quick set and release coupling system.

Additional stitching is required for elements with leather upholstery compared to elements with fabric upholstery.



**Cm**

224 x 244 x 98 (160 x 200)\*  
244 x 244 x 98 (180 x 200)\*  
264 x 244 x 98 (200 x 200)\*  
217 x 247 x 98 (153 x 203)\*  
257 x 247 x 98 (193 x 203)\*  
247 x 257 x 98 (183 x 213)\*

**Inches**

88 1/4" x 96 1/4" x 38 3/4" (63" x 78 3/4")\*  
96 1/4" x 96 1/4" x 38 3/4" (71" x 78 3/4")\*  
104" x 96 1/4" x 38 3/4" (78 3/4" x 78 3/4")\*  
85 1/2" x 97 1/4" x 38 3/4" (60 1/4" x 80")\*  
101 1/4" x 97 1/4" x 38 3/4" (76" x 80")\*  
97 1/4" x 101 1/4" x 38 3/4" (72 1/4" x 84")\*

\* Materasso (L x P)

\* Mattress (W x D)

[For technical drawing / p. 487](#)

[Pricelist 2023 / p. 306](#)  
[Homescapes, sense of materials / p. 110](#)  
[Homescapes, embracing beauty / p. 106](#)

**RIVESTIMENTO/COVER**



Tessuto/pelle nei colori del campionario  
Fabric/leather as per samples.



# Yuki

Massimo Castagna / 2019

Letto imbottito in poliuretano espanso indeformabile a densità differenziate e fibra poliestere. Testata autoportante imbottita con pannelli laterali orientabili. Rete a doghe inclusa. Disponibile con rivestimento in tessuto o pelle nei colori di campionario. Dettagli in ottone satinato o laccato nero opaco. Su richiesta versione con prese USB (una per ogni lato).

Bed in non-deformable foam polyurethane in different density and polyester fibre. Freestanding upholstered headboard with adjustable side panels. Wooden slats included. Available covered by fabric or leather as per samples. Satin brass or opaque black lacquered brass details. USB charger ports version (one for each side) on request.

**!** Giroletto sfoderabile.

La testata è fissata al giroletto tramite un sistema di aggancio meccanico.

Per la realizzazione di elementi con rivestimento in pelle sono necessarie cuciture aggiuntive rispetto gli elementi con rivestimento in tessuto.

**!** Removable cover for bed frame.

The headboard is fastened to the bed frame through a mechanic system.

Additional stitching is required for elements with leather upholstery compared to elements with fabric upholstery.



**Cm**

343 x 225 x 135 (160 x 200)\*  
363 x 225 x 135 (180 x 200)\*  
393 x 225 x 135 (200 x 200)\*  
343 x 228 x 135 (153 x 203)\*  
393 x 228 x 135 (193 x 203)\*  
363 x 238 x 135 (183 x 213)\*

**Inches**

135<sup>3</sup>/<sub>4</sub>" x 88<sup>3</sup>/<sub>4</sub>" x 53<sup>1</sup>/<sub>4</sub>" (63" x 78<sup>3</sup>/<sub>4</sub>")\*  
143" x 88<sup>3</sup>/<sub>4</sub>" x 53<sup>1</sup>/<sub>4</sub>" (71" x 78<sup>3</sup>/<sub>4</sub>")\*  
154<sup>3</sup>/<sub>4</sub>" x 88<sup>3</sup>/<sub>4</sub>" x 53<sup>1</sup>/<sub>4</sub>" (78<sup>3</sup>/<sub>4</sub>" x 78<sup>3</sup>/<sub>4</sub>")\*  
135<sup>1</sup>/<sub>4</sub>" x 90" x 53<sup>1</sup>/<sub>4</sub>" (60<sup>1</sup>/<sub>4</sub>" x 80")\*  
154<sup>3</sup>/<sub>4</sub>" x 90" x 53<sup>1</sup>/<sub>4</sub>" (76" x 80")\*  
143" x 93<sup>3</sup>/<sub>4</sub>" x 53<sup>1</sup>/<sub>4</sub>" (72<sup>1</sup>/<sub>4</sub>" x 84")\*

\* Materasso (L x P)

\*Mattress (W x D)

[For technical drawing / p. 488](#)

[Pricelist 2023 / p. 308](#)

[Homescapes, sense of materials / p. 72](#)

[Homescapes, embracing beauty / p. 54](#)

[Homescapes, intimate portraits / p. 88, 93](#)

**RIVESTIMENTO/COVER**



Tessuto/pelle nei colori del campionario  
Fabric/leather as per samples.

**DETTAGLI/DETAILS**



Ottone satinato  
Satin brass

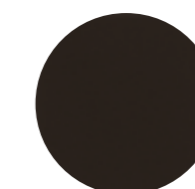

Laccato nero opaco  
Matt black lacquered

**VERSIONE CON USB/  
USB VERSION**

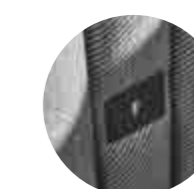

# 10

**Letti / Beds**  
**TECHNICAL MODULE**

**GENERAL INDICATION**

■ tessuto/pelle consigliato  
suggested fabric/leather  
tissu/cuir conseillé  
empfohlener Stoff/Leder

□ tessuto/pelle non utilizzabile  
non-usable fabric/leather  
tissu/cuir non utilisable  
nicht verwendbarer Stoff/Leder

	CAT.A												CAT.B												CAT.C												CAT.D		CAT.L1		CAT.L2										
	Care	Chill	Cozy	Delight	Gape	Hope	Infinity	Joy	Savage	Velvet	Berlino	Daze	Della	Glee	Glow	Harmony	Maze	Mingle	Path	Perky	Perseo	Sofi	Soul	Tokyo	Touch	Twist	Vision	Armònia	Bloom	Eden	Euphoria	Fluffy	Freedom	Futura	Utopia	Wonder	Alko	Pleasure	Zest	Fard	Soft	Suede	Leather	Nabuk							
Eve	□	□	□	□	□	□	□	□	■	□	□	□	□	□	□	□	□	□	□	□	□	□	□	□	□	□	□	□	□	□	□	□	□	□	□	□	□	□	□	□	□	□	□	□	□	■					
Lilas Bed	■	■	■	■	■	■	■	■	■	■	■	■	■	■	■	■	■	■	■	■	■	■	■	■	■	■	■	■	■	■	■	■	■	■	■	■	■	■	■	■	■	■	■	■	■	■	■	■	■		
Sunrise	■	■	■	■	■	■	■	■	■	■	■	■	■	■	■	■	■	■	■	■	■	■	■	■	■	■	■	■	■	■	■	■	■	■	■	■	■	■	■	■	■	■	■	■	■	■	■	■	■	■	
Xeni	■	■	■	■	■	■	■	■	■	□	■	■	■	■	■	■	■	■	■	■	■	■	■	■	■	■	■	■	■	■	■	■	■	■	■	■	■	■	■	■	■	■	■	■	■	■	■	■	■	■	
Yuki	■	■	■	■	□	■	■	■	■	■	■	■	■	■	■	■	■	■	■	■	■	■	■	■	■	■	■	■	■	■	■	■	■	■	■	■	■	■	■	■	■	■	■	■	■	■	■	■	■	■	■
cushions	■	■	■	■	■	■	■	■	■	■	■	■	■	■	■	■	■	■	■	■	■	■	■	■	■	■	■	■	■	■	■	■	■	■	■	■	■	■	■	■	■	■	■	■	■	■	■	■	■	■	■

**Cuscini decorativi**  
Decorative cushions



Ø38  
Ø15"

Cuscino decorativo in fibra poliestere e chiusura con cerniera.

Decorative polyester fibre cushion with zip closure.

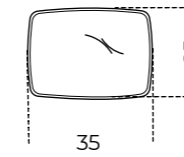

35 x 25  
14" x 10"

Cuscino decorativo in fibra poliestere rifinito con bordo perimetrale e chiusura con cerniera.

Decorative polyester fibre cushion finished with perimetral trim and zip closure.

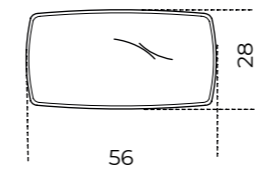

56 x 28  
22 3/4" x 11 1/4"

Cuscino decorativo in fibra poliestere rifinito con bordo perimetrale e chiusura con cerniera.

Decorative polyester fibre cushion finished with perimetral trim and zip closure.

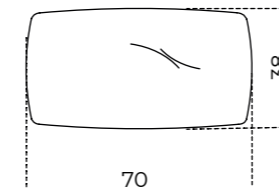

70 x 38  
15 3/4" x 15"

Cuscino decorativo in fibra poliestere e chiusura con cerniera.

Decorative polyester fibre cushion with zip closure.

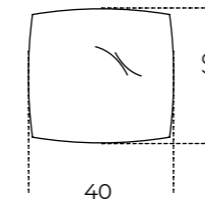

40 x 40  
27 3/4" x 15 3/4"

Cuscino decorativo in fibra poliestere e chiusura con cerniera.

Decorative polyester fibre cushion with zip closure.

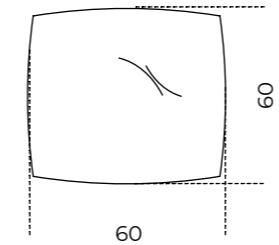

60 x 60  
23 3/4" x 23 3/4"

Cuscino decorativo in fibra poliestere e chiusura con cerniera.

Decorative polyester fibre cushion with zip closure.

! Gallotti&Radice declina ogni responsabilità rispetto le prestazioni tecniche ed estetiche dei prodotti realizzati con tessuti/pelli non consigliate.

Gallotti&Radice declina ogni responsabilità rispetto alle prestazioni tecniche ed estetiche dei prodotti rivestiti con C.O.L. e C.O.M.

Per informazioni di dettaglio relative alla composizione, proprietà e lavaggio/manutenzione dei rivestimenti si rinvia al "Volume 4 | Materiali".

È possibile rivestire tutti i prodotti della collezione Gallotti&Radice con con tessuto/pelle cliente, previa approvazione di un campione. Gallotti&Radice non è responsabile per quanto riguarda il risultato formale, la durata del tessuto e la costanza dei colori (vedi: "Volume 4 | Materiali").

L'approvazione del tessuto fornito dal Cliente da parte di Gallotti&Radice si limita solamente alla realizzazione della tappezzeria.

Gallotti&Radice declina pertanto ogni responsabilità in merito alla resistenza all'uso, alla eventuale resistenza al fuoco o ad altre caratteristiche tecniche dei tessuti forniti dal Cliente.

Gallotti&Radice non è responsabile dei materiali inviati dal cliente, di eventuali difetti e carenze tecniche degli stessi, delle possibili reazioni difettose a prodotto tappezzato nonché delle istruzioni riguardanti manutenzione e lavaggio.

! Gallotti & Radice declines all responsibility for the technical and aesthetical performances of products made with non-recommended fabrics / leathers.

Gallotti & Radice declines all responsibility for technical and aesthetic performance of products covered with C.O.L. and C.O.M.

For detailed information on the composition, properties and maintenance of the upholstery, please refer to the "Volume 4 | Materials".

Furniture may be upholstered with customers' own fabrics after approval of a sample. Gallotti&Radice is not responsible for the aesthetic result, durability of the fabric and the uniformity of the colours (see: Volume 4 | Materials).

The approval by Gallotti&Radice of the C.O.L. and C.O.M is limited only to the upholstery. Gallotti&Radice therefore declines all responsibility for resistance to use, any resistance to fire or other technical characteristics of the fabrics supplied by the customer.

Gallotti & Radice is not responsible for the materials sent by the customer, for any defects and technical deficiencies of the same, for possible defective reactions to the upholstered product as well as for the instructions regarding maintenance and washing.

**Eve** | Pietro Russo, 2021

Product information / p. 474

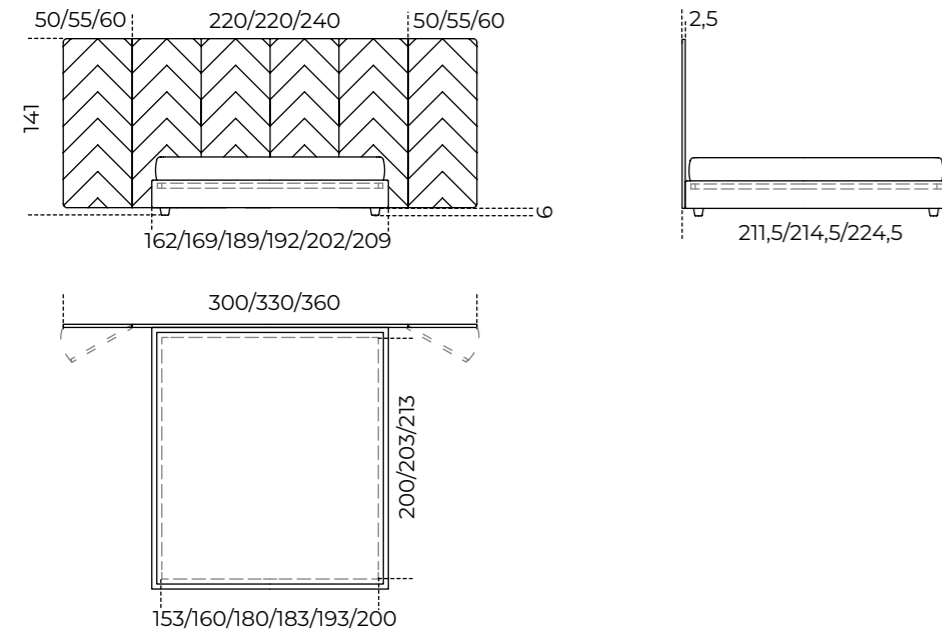

**Versione con comodini**

Bedside table version

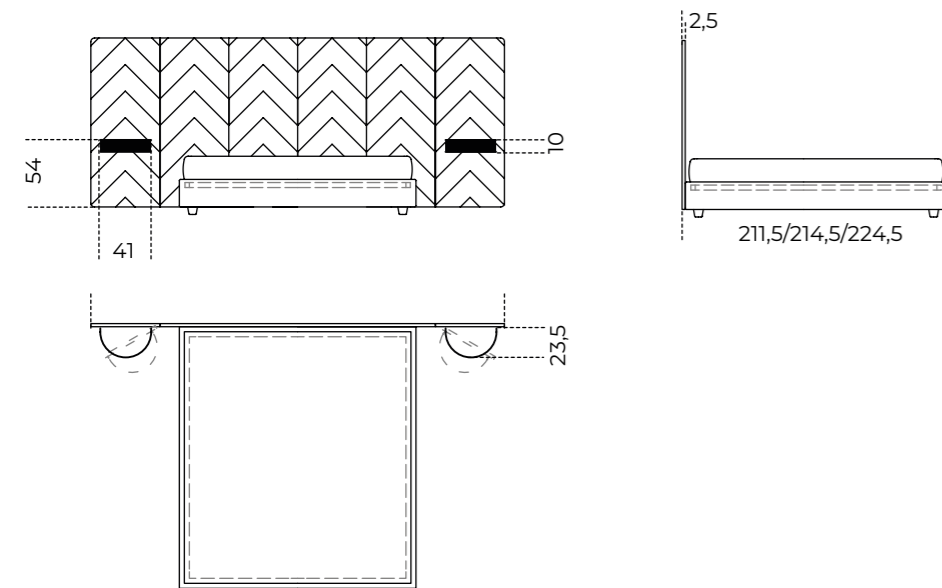

**Lilas Bed** | Dainelli Studio, 2022

Product information / p. 476

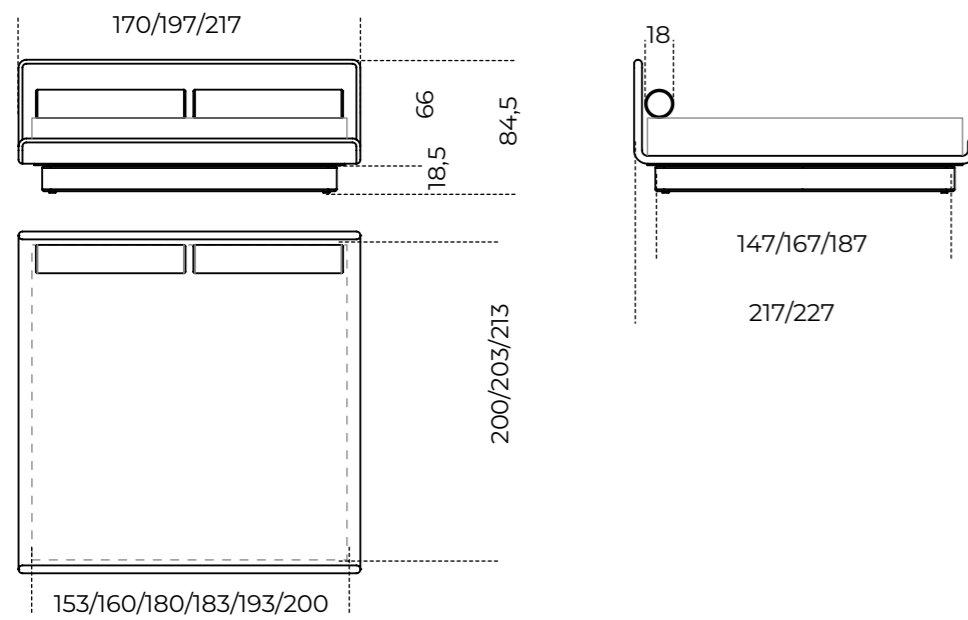

**Sunrise** | Studioepe, 2024

Product information / p. 478

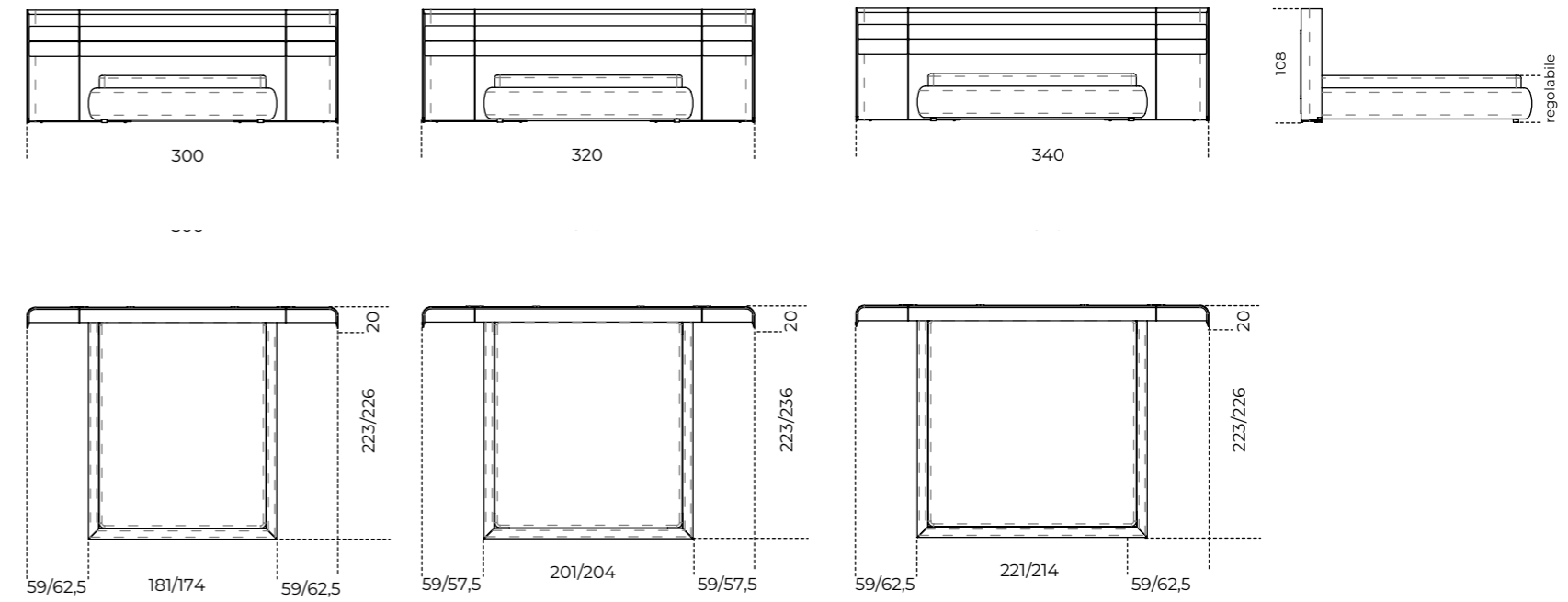

**Xeni** | Massimo Castagna, 2018

Product information / p. 480

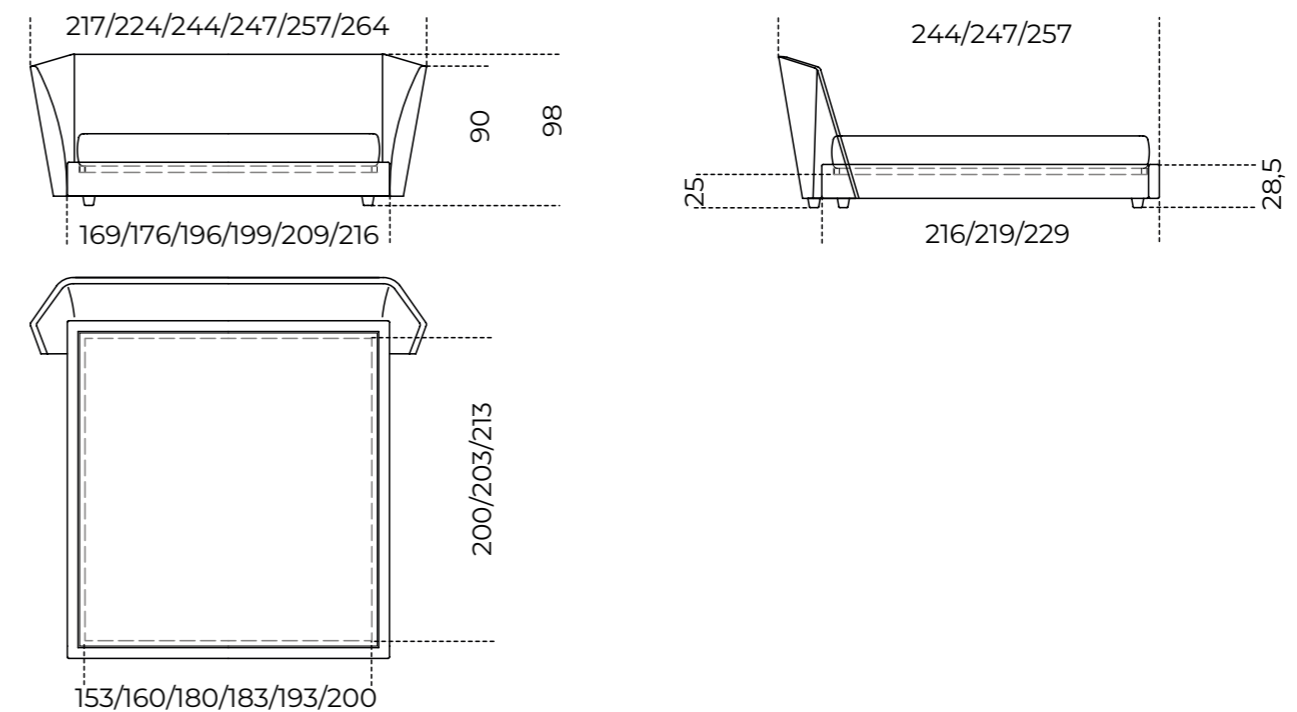

**Yuki** | Massimo Castagna, 2019

Product information / p.482

**Versione senza prese USB**  
Version without USB socket

**Fronte**  
Front

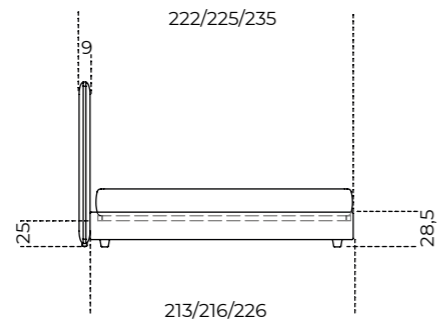
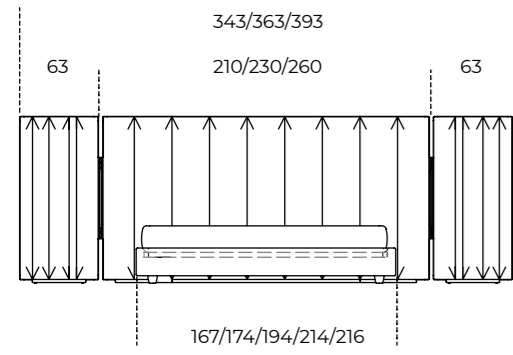

**Retro**  
Back

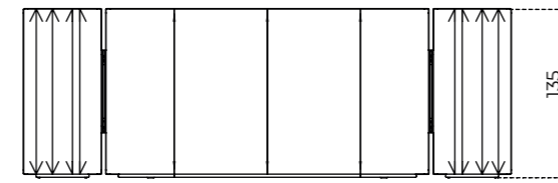

**Versione con prese USB**  
Version with USB socket

**Fronte**  
Front

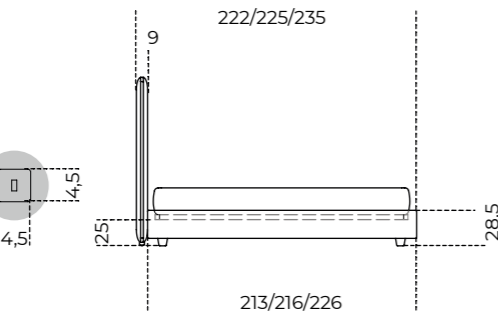
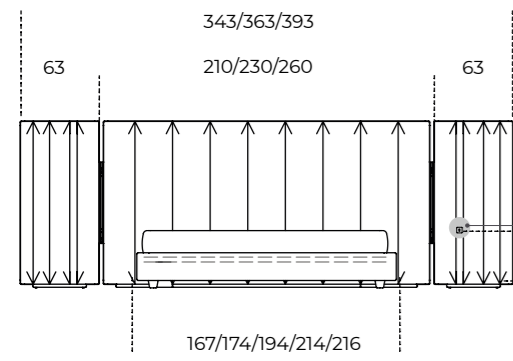

**Retro**  
Back

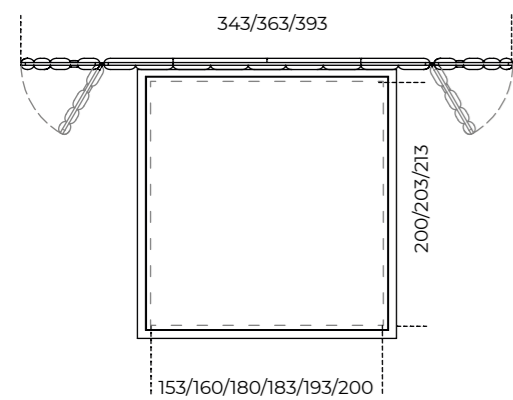
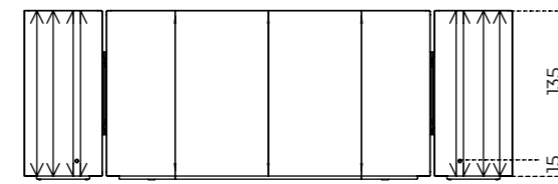

## **11** Complementi notte / Night accessories

- 492 **Duale**
- 494 **Hide&Seek Mini**
- 496 **Holly Comò**
- 498 **Holly Comodino**
- 500 **Kumi**
- 502 **Stami Night**
- 504 **Twelve C**
  
- 506 **Informazioni tecniche/**  
[Technical informations](#)



▲ **DUALE**  
Struttura in legno intarsiato Noce Colore Frisé / Interno in Tanganika bianco Frisé  
"Colore" Frisé Walnut inlaid wood structure / Tanganika white Frisé inside

# Duale

Pietro Russo / 2019

Guardaroba a giorno in legno intarsiato Noce "Colore" Frisé. Interni rivestiti in Tanganika bianco Frisé. Accessoriato con appendiabiti e ripiano in legno (A) oppure a più ripiani (B).

! Il legno è un materiale vivo che subisce un naturale processo di ossidazione che può causare cambiamenti cromatici. Venature e tonalità di colore differenti delle lastre non sono da considerarsi come difetti, ma caratteristiche che esaltano l'unicità del materiale.

#### NOTE TECNICHE SUI MATERIALI

**INTARSIO** | L'intarsio è una tecnica di lavorazione artigianale utilizzata per ottenere un particolare disegno e si realizza accostando elementi di materiali differenti (come legno e alluminio) oppure dello stesso materiale. Questa lavorazione rende il prodotto unico ed esclusivo. Le eventuali variazioni cromatiche e di venatura del legno sono da considerarsi caratteristiche del materiale stesso e non possono essere controllate.

Wardrobe in "Colore" Frisé Walnut inlaid wood. Inside covered by Tanganika white Frisé wood. Supplied with one clothes rail and wooden shelf (A) or wooden multiple shelves (B).

! Wood is a living material and the natural oxidation process can cause chromatic changes. Different grain and colour shades of the wooden slabs are not to be considered as defects, but characteristics that enhance the uniqueness of the material.

#### TECHNICAL INFORMATION ON THE MATERIALS

**INLAY** | Inlay is an artisanal technique used to obtain a particular design and is made by combining elements of different materials (such as wood and aluminium) or of the same material. This process makes the product unique and exclusive. Any colour and grain variations of the wood are to be considered as characteristics of the material itself and cannot be controlled.



	Cm	Inches
A	100 x 57 x 180	39½" x 22½" x 71"
B	100 x 57 x 180	39½" x 22½" x 71"

For technical drawing / p. 508

Pricelist 2023 / p. 296  
Homescapes, sense of materials / p. 81

#### STRUTTURA/STRUCTURE



Legno intarsiato  
Noce "Colore" Frisé  
"Colore" Frisé Walnut  
inlaid wood

#### INTERNO/INSIDE



Tanganika bianco Frisé  
Tanganika white Frisé

#### DETTAGLI/DETAILS



Ottone satinato  
Satin brass



▲ **HIDE&SEEK MINI**  
Struttura in legno laccato opaco "Sabbia del Nilo"  
"Sabbia del Nilo" opaque lacquered wood structure

# Hide&Seek Mini

Pietro Russo / 2024

Tavolino con struttura, cilindro girevole e ripiano in legno laccato lucido o opaco. Colori disponibili: "Rosso Persia", "Grigio Londra", "Nero Giza", "Bianco Camargue", "Verde Provenza", "Blu Pacifico", "Bordeaux Etruria", "Rosa Jaipur" e "Sabbia del Nilo".

Coffee table with structure, rotating half-cylinder and shelf in glossy or opaque lacquered wood. Available colours: "Rosso Persia", "Grigio Londra", "Nero Giza", "Bianco Camargue", "Verde Provenza", "Blu Pacifico", "Bordeaux Etruria", "Rosa Jaipur" or "Sabbia del Nilo".



**Cm**  
Ø47 x 44,5h

**Inches**  
18¾" x 17¾"

[For technical drawing / p. 508](#)

[Pricelist 2023 / p. 225](#)  
[Homescapes, gentle attitude / p. 69](#)

## STRUTTURA/STRUCTURE



Legno laccato lucido  
"Nero Giza"  
"Nero Giza" glossy  
lacquered wood



Legno laccato opaco  
"Nero Giza"  
"Nero Giza" opaque  
lacquered wood



Legno laccato lucido  
"grigio Londra"  
"Grigio Londra" glossy  
lacquered wood

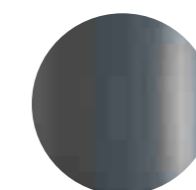

Legno laccato opaco  
"grigio Londra"  
"Grigio Londra" opaque  
lacquered wood



Legno laccato lucido  
"Blu Pacifico"  
"Blu Pacifico" glossy  
lacquered wood

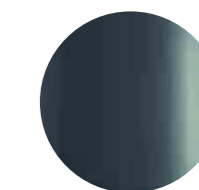

Legno laccato opaco "Blu Pacifico"  
"Blu Pacifico" opaque  
lacquered wood



Legno laccato lucido  
"Verde Provenza"  
"Verde Provenza" glossy  
lacquered wood

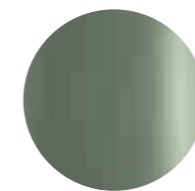

Legno laccato opaco  
"Verde Provenza"  
"Verde Provenza" opaque  
lacquered wood

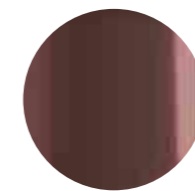

Legno laccato lucido  
"Bordeaux Etruria"  
"Bordeaux Etruria" glossy  
lacquered wood

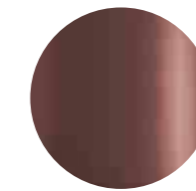

Legno laccato opaco  
"Bordeaux Etruria"  
"Bordeaux Etruria" opaque  
lacquered wood

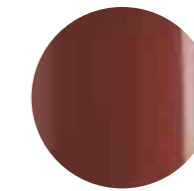

Legno laccato lucido  
"Rosso Persia"  
"Rosso Persia" glossy  
lacquered wood

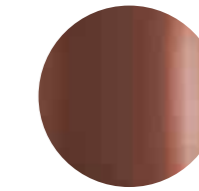

Legno laccato opaco  
"Rosso Persia"  
"Rosso Persia" opaque  
lacquered wood

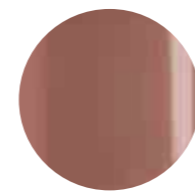

Legno laccato lucido  
"Rosa Jaipur"  
"Rosa Jaipur" glossy  
lacquered wood

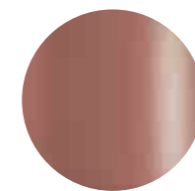

Legno laccato opaco  
"Rosa Jaipur"  
"Rosa Jaipur" opaque  
lacquered wood



Legno laccato lucido  
"Sabbia del Nilo"  
"Sabbia del Nilo" glossy  
lacquered wood



Legno laccato opaco  
"Sabbia del Nilo"  
"Sabbia del Nilo"  
opaque lacquered wood

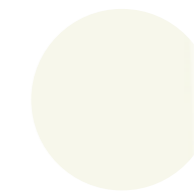

Legno laccato lucido  
"Bianco Camargue"  
"Bianco Camargue" glossy  
lacquered wood



Legno laccato opaco  
"Bianco Camargue"  
"Bianco Camargue"  
opaque lacquered wood





#### ▲ HOLLY COMÒ

Struttura e cassetti in frassino tinto nero poro aperto / Piano e spalle in cristallo fumè "grigio talia" / Inserti in Velvet peacock 705  
Black open pore lacquered ash structure and drawers / Top and sides in smoked "grigio Italia" / Inserts cover in Velvet peacock 705

# Holly Comò

Pinuccio Borgonovo / 2020

Comò con due cassetti grandi, un cassetto piccolo, vano a giorno e piano estraibile con inserto in velluto disponibile nei colori del campionario. Cassetti montati su guide a estrazione totale. Struttura e piano estraibile in frassino tinto nero a poro aperto oppure tinto grigio smoke a poro aperto. Piano superiore e fianchi in cristallo temperato "grigio Italia" oppure cristallo extralight 10mm. Parti metalliche in alluminio spazzolato anodizzato nero. Su richiesta vassoio porta oggetti da inserire all'interno dei cassetti, realizzato in legno grigio con fondo rivestito in velluto disponibile nei colori del campionario.

Chest of drawers with two big drawers, one small drawer, open module and pull-out tray with velvet pad available as per samples. Drawers with total extraction runners. Structure and pull-out tray in either black open pore stained ash or grey smoke open pore stained ash. 10mm smoked "grigio Italia" or extralight glass top and sides. Metal parts in brushed black anodized aluminium. Grey wooden accessories tray with velvet bottom to be placed inside the drawers on request. Velvet finishes as per samples.



#### Cm

130 x 52 x 74  
155 x 52 x 74

#### Inches

51¼" x 20½" x 29¼"  
61¼" x 20½" x 29¼"

For technical drawing / p. 508

Pricelist 2023 / p. 297  
Homescapes, embracing beauty / p. 55  
Homescapes, gentle attitude / pp. 98, 99, 103

#### STRUTTURA E PIANO ESTRAIBILE/STRUCTURE AND PULL-OUT TRAY

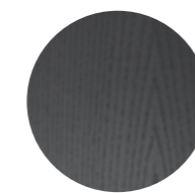

Frassino tinto  
nero a poro aperto  
Black open pore  
stained ash



Frassino tinto  
grigio smoke a poro aperto  
Grey Smoke open pore  
stained ash

#### TOP E FIANCHI/ TOP AND SIDES



Cristallo fumè  
"grigio Italia"  
"Grigio Italia" smoked glass



Cristallo extralight  
Extralight glass

#### INSERTO PIANO ESTRAIBILE E FONDO VASSOIO PORTA OGGETTI/ PULL OUT TRAY PAD AND ACCESSORIES TRAY BOTTOM



Velluto nei colori del  
campionario  
Velvet as per samples.

#### PARTI METALLICHE/ METAL PARTS



Alluminio spazzolato  
anodizzato nero  
Black brushed aluminium



#### ▲ HOLLY COMODINO

Struttura in frassino tinto nero poro aperto / Piano e fianchi in cristallo fumè "grigio talia" / Piano superiore del cassetto in frassino tinto nero poro aperto  
Black open pore lacquered ash structure / Top and sides in smoked "grigio Italia" / Upper shelf of the drawer in black open pore lacquered ash

# Holly Comodino

Pinuccio Borgonovo / 2020

Comodino con un cassetto. Struttura in frassino tinto nero a poro aperto oppure tinto grigio smoke a poro aperto. Cassetto montato su guide a estrazione totale. Piano superiore e fianchi in cristallo temperato "grigio Italia" oppure cristallo extralight 10mm. Parti metalliche in alluminio spazzolato anodizzato nero. Dotato di piano superiore del cassetto in frassino tinto nero a poro aperto oppure tinto grigio smoke a poro aperto come la struttura. Su richiesta disponibile in cristallo temperato decorato Craquelé oppure verniciato nella finitura esclusiva spazzolata "Cashmere" nei colori gold grey o anthracite.

Bedside table with one drawer. Structure in black open pore stained ash or grey smoke open pore stained ash. Drawer with total extraction runners. 10mm smoked "grigio Italia" or extralight glass tempered top and sides. Metal parts in brushed black anodized aluminium. Upper top of the drawer in black open pore stained ash or grey smoke open pore stained ash like the structure. Alternatively available in either tempered Craquelé glass or tempered painted with the exclusive "Cashmere" brushed glass finish in the gold grey or anthracite on request.

#### NOTE TECNICHE SUI MATERIALI

**CRISTALLO** | Le finiture esclusive, risultato della lavorazione manuale realizzata su cristallo, possono presentare striature e differenze cromatiche. Queste caratteristiche non devono essere considerate difetti ma elementi distintivi del processo artigianale che esaltano la bellezza e la peculiarità del pezzo unico.

#### TECHNICAL INFORMATION ON THE MATERIALS

**GLASS** | Exclusive finishes, resulting from the craftsmanship on the glass, may show streaks and chromatic differences. These characteristics should not be considered imperfections but distinctive evidence of the hand-made process that enhance the beauty and peculiarity of the unique piece.



#### Cm

50 x 48 x 47  
80 x 48 x 47

#### Inches

19¾" x 19" x 18¾"  
31½" x 19" x 18¾"

[For technical drawing / p. 509](#)

[Pricelist 2023 / p.298](#)  
[Homescapes, embracing beauty / p. 54](#)

#### STRUTTURA/STRUCTURE

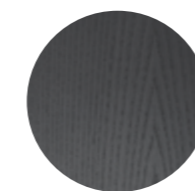

Frassino tinto  
nero a poro aperto  
Black open pore  
stained ash



Frassino tinto  
grigio smoke a poro aperto  
Grey Smoke open pore  
stained ash

#### TOP E FIANCHI/ TOP AND SIDES



Cristallo "grigio Italia"  
"Grigio Italia" smoked glass



Cristallo extralight  
extralight glass

#### PARTI METALLICHE/ METAL PARTS



Alluminio spazzolato  
anodizzato nero  
Black brushed aluminium

#### PIANO SUPERIORE CASSETTO/ UPPER SHELF OF THE DRAWER

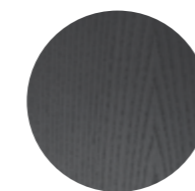

Frassino tinto  
nero a poro aperto  
Black open pore  
stained ash



Frassino tinto  
grigio smoke a poro aperto  
Grey Smoke open pore  
stained ash



Cristallo Craquelé  
Craquelé glass



Cristallo spazzolato  
"Cashmere" gold grey  
"Cashmere" gold grey  
brushed glass



Cristallo spazzolato  
"Cashmere" anthracite  
"Cashmere" anthracite  
brushed glass



▲ KUMI COMÒ  
Piano in marmo bisellato Calacatta vagli oro/ Struttura in tiglio tinto nero poro aperto e fascia zigrinata a mano  
Calacatta vagli oro bevelled marble top / Black lacquered open pore limewood and hand knurled border

# Kumi

Carlo Colombo / 2020

Mobile con struttura in legno tinto nero a poro aperto, rivestita frontalmente e lateralmente con fascia zigrinata a mano.  
Maniglie e parti metalliche in metallo laccato color fango.  
Piano disponibile in marmo 20mm bisellato lucido naturale Calacatta Vagli Oro, Verde Alpi, Arabescato Orobico Rosso satinato, Dover White satinato oppure cristallo temperato 6mm retroverniciato nero brillante.  
Vani con anta dotati di ripiano in legno.

Disponibile nelle seguenti versioni:

Versione h 73,2/74,6 con ante e cassetti.  
Versione h 73,2/74,6 con ante, cassetti e vano a giorno  
Versione h 108,6/110 con ante, cassetti e vano a ribalta con schienale interno specchiato 6mm e dotato di luce interna LED attivata da un sensore all'apertura dell'anta.

#### NOTE TECNICHE SUI MATERIALI

**MARMO** | Il marmo è un materiale naturale di origine sedimentaria che può presentare particolarità come venature, lievi irregolarità superficiali, colorazioni differenti e cristallizzazioni. Queste peculiarità sono da attribuirsi alla naturalezza del materiale e non sono da considerarsi difetti ma caratteristiche tipiche del marmo. Ogni prodotto risulterà unico, esclusivo e non replicabile.  
I nostri marmi vengono trattati con un prodotto idrorepellente che permette una maggiore protezione della superficie stessa, aumentando l'impermeabilità. Questo trattamento non esclude la vulnerabilità del marmo alle sostanze acide.

Sideboard with structure in black stained open pore wood. Front and sides clad with hand knurled border.  
Handles and metal parts lacquered in the "fango" colour.  
Top available in bevelled natural polished Calacatta Vagli Oro, natural polished Verde Alpi, satin Arabescato Orobico Rosso marble, satin Dover White or 6mm thick tempered bright black painted glass.  
Modules with doors supplied with inside wooden shelf.

Available in the following versions:

Version h 73,2/74,6 with doors and drawers.  
Version h 73,2/74,6 with doors, drawers and open module.  
Version h 108,6/110 with side doors, drawers and unit with flap door with 6mm inside mirrored back and supplied with inside LED light turned on by sensor as flap door is opened.

#### TECHNICAL INFORMATION ON THE MATERIALS

**MARBLE** | The marble is a natural material of sedimentary origin that can present particularities such as veins, slight surface irregularities, different colors and crystallizations. These peculiarities are to be attributed to the naturalness of the material and are not to be considered defects but typical characteristics of marble. Each product will be unique, exclusive and non-replicable.  
Our marbles are treated with water-repellent products which affords greater protection to the surface of the marble, improving its impermeability. This treatment doesn't exclude the vulnerability of the marble to acid substances.



#### Cm

**Top cristallo**  
143 x 50 x 73,2  
194 x 50 x 73,2  
143 x 50 x 108,6

#### Top marmo

143 x 50 x 74,6  
194 x 50 x 74,6  
143 x 50 x 110

#### Inches

**Glass top**  
56½" x 19¾" x 29"  
76½" x 19¾" x 29"  
56½" x 19¾" x 43"

#### Marble top

56½" x 19¾" x 29½"  
76½" x 19¾" x 29½"  
56½" x 19¾" x 43½"

For technical drawing / p. 509

Pricelist 2023 / p. 253  
Homescapcs, embracig beauty / p. 22

#### STRUTTURA/STRUCTURE



**Legno tinto nero poro aperto**  
Black open pore stained wood

#### VERSIONE PIANO MARMO/MARBLE TOP VERSION



**Marmo lucido naturale Calacatta Vagli Oro**  
Natural polished Calacatta Vagli Oro marble



**Marmo lucido naturale Verde Alpi**  
Natural polished Verde Alpi marble



**Marmo Arabescato Orobico Rosso satinato**  
Arabescato Orobico Rosso satin marble

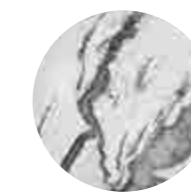

**Marmo satinato Dover white**  
Satin Dover white marble

#### VERSIONE PIANO CRISTALLO/ GLASS TOP VERSION

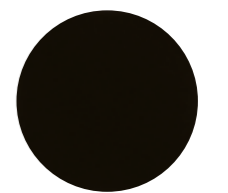

**Cristallo retroverniciato nero brillante**  
Bright black painted glass

#### VERSIONE H.110/ H.110 VERSION

#### SCHIENALE INTERNO/ INSIDE BACK



**Specchio**  
Mirror

#### LUCE INTERNA/ INSIDE LIGHT

LED 15W  
108 lm  
3000K  
Cable lenght: 1,5mt

#### PARTI METALLICHE/ METAL PARS

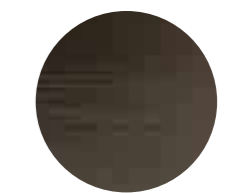

**Metallo laccato "fango"**  
Metal lacquered "fango"



▲ **TWELVE C**  
Struttura in Frassino tinto nero poro aperto e ottone brunito a mano / Piano in cristallo Craquelé  
Black open pore lacquered ash and hand burnished brass structure / Craquelé glass top

# Stami Night

Studiopepe / 2023

Comodino con cassetto con base in frassino curvato tinto nero a poro aperto e dettagli in ottone lucido. Struttura in legno con rivestimento in pelle o pelle scamosciata nei colori del campionario.

Bedside with drawer with curved black open pore stained ash base and bright brass details. Wooden structure covered by leather or suede as per samples.

! Per la realizzazione di elementi con rivestimento in pelle sono necessarie cuciture aggiuntive rispetto gli elementi con rivestimento in tessuto.

! Additional stitching is required for elements with leather upholstery compared to elements with fabric upholstery.



**Cm**  
69 x 45 x 49,5

**Inches**  
27¼" x 17¾" x 19½"

[For technical drawing / p. 510](#)

[Pricelist 2023 / p. 300](#)

## BASE/BASE



Frassino curvato tinto  
nero a poro aperto  
Curved black open pore  
stained ash

## DETTAGLI/DETAILS



Ottone lucido  
Bright brass

## STRUTTURA/STRUCTURE



Legno rivestito in pelle o  
pelle scamosciata  
nei colori del campionario  
Wooden structure covered  
by leather or suede  
as per samples.

# Twelve C

Massimo Castagna / 2018

Comodino in frassino tinto nero a poro aperto. Piano in cristallo 6mm decorato a mano nella finitura Craquelé oppure retroverniciato liquirizia brillante. Struttura in ottone brunito a mano.

## NOTE TECNICHE SUI MATERIALI

**OTTONE BRUNITO A MANO** | L'ottone brunito a mano è ottenuto da un processo di ossidazione naturale eseguito manualmente. Il risultato di questa lavorazione è un prodotto che può presentare macchie e variazioni di colore che non sono da considerarsi imperfezioni ma caratteristiche che conferiscono ad ogni pezzo una particolare unicità, rendendolo esclusivo.

**CRISTALLO** | Le finiture esclusive, risultato della lavorazione manuale realizzata sul cristallo, possono presentare striature e differenze cromatiche. Queste caratteristiche non devono essere considerate difetti ma elementi distintivi del processo artigianale che esaltano la bellezza e la peculiarità del pezzo unico.

Black open pore stained ash night table. 6mm hand decorated Craquelé or bright liquorice painted glass top. Hand burnished brass structure.

## TECHNICAL INFORMATION ON THE MATERIALS

**HAND BURNISHED BRASS** | The hand burnished brass is the consequence of hand-made process of natural oxidation. The result of this processing is a product that may show marks and colour variations. These differences are inevitable and should not be considered imperfections but evidence of the hand-crafted process. They enhance the beauty and distinctiveness of a unique piece.

**GLASS** | Exclusive finishes, resulting from the craftsmanship on the glass, may show streaks and chromatic differences. These characteristics should not be considered imperfections but distinctive evidence of the hand-made process that enhance the beauty and peculiarity of the unique piece.



	Cm	Inches
A	40 x 40 x 49	15¾" x 15¾" x 19½"
B	40 x 40 x 54	15¾" x 15¾" x 21½"
C	80 x 40 x 49	31½" x 15¾" x 19½"

[For technical drawing / p. 510](#)

[Pricelist 2023 / p. 301](#)  
[Homescapes, sense of materials / p. 112](#)  
[Homescapes, embracing beauty / p. 107](#)  
[Homescapes, intimate portraits / p. 89](#)

## ▲ TWELVE C

Struttura in Frassino tinto nero poro aperto e ottone brunito a mano / Piano in cristallo Craquelé  
 Black open pore lacquered ash and hand burnished brass structure / Craquelé glass top

## STRUTTURA/STRUCTURE



Frassino tinto  
 nero a poro aperto/  
 ottone brunito a mano  
 Black open pore  
 stained ash/  
 Hand burnished brass

## PIANO/TOP



Cristallo Craquelé  
 Craquelé glass

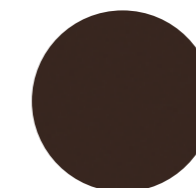

Cristallo retroverniciato  
 liquirizia brillante  
 Black bright liquorice  
 painted glass

# 11

**Complementi notte / Night accessories**  
**TECHNICAL MODULE**

**Duale** | Pietro Russo, 2019

Product information / p. 492

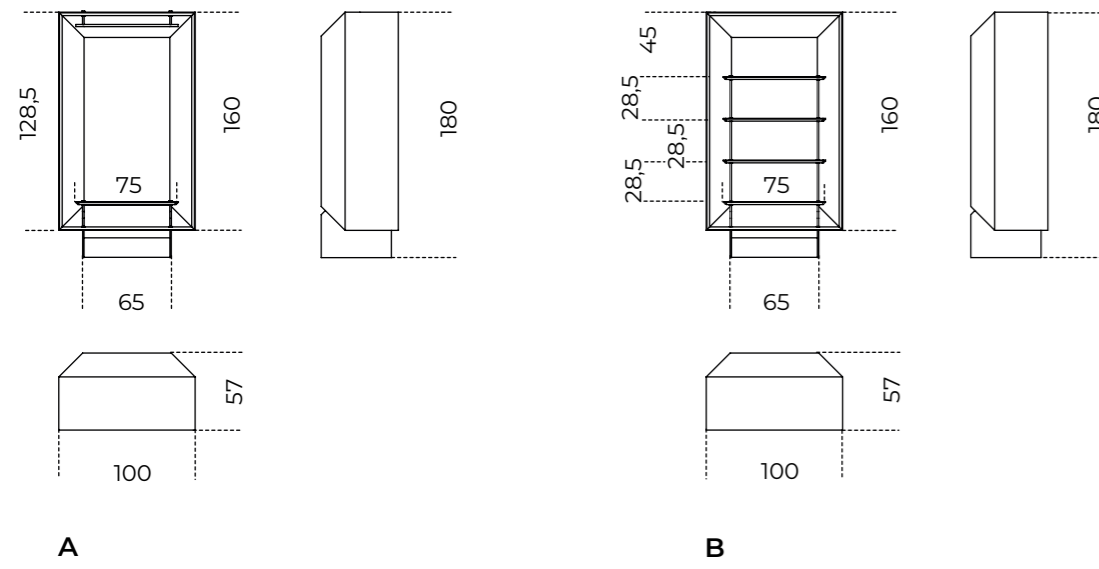

**Holly Comodino** | Pinuccio Borgonovo, 2020

Product information / p. 498

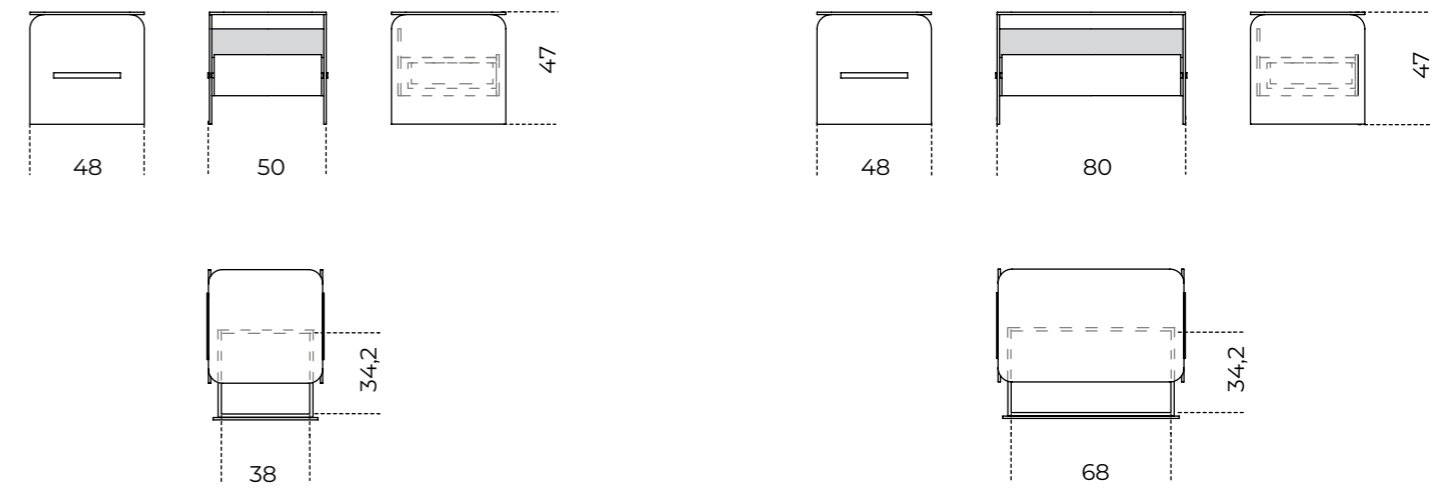

**Hide&Seek Mini** | Pietro Russo, 2024

Product information / p. 494

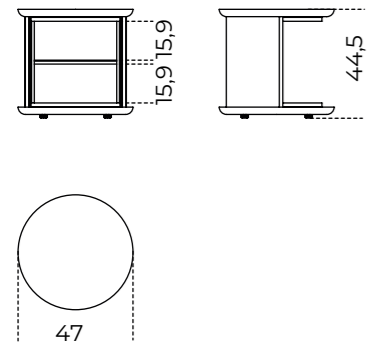

**Kumi Comò** | Carlo Colombo, 2020

Product information / p. 500

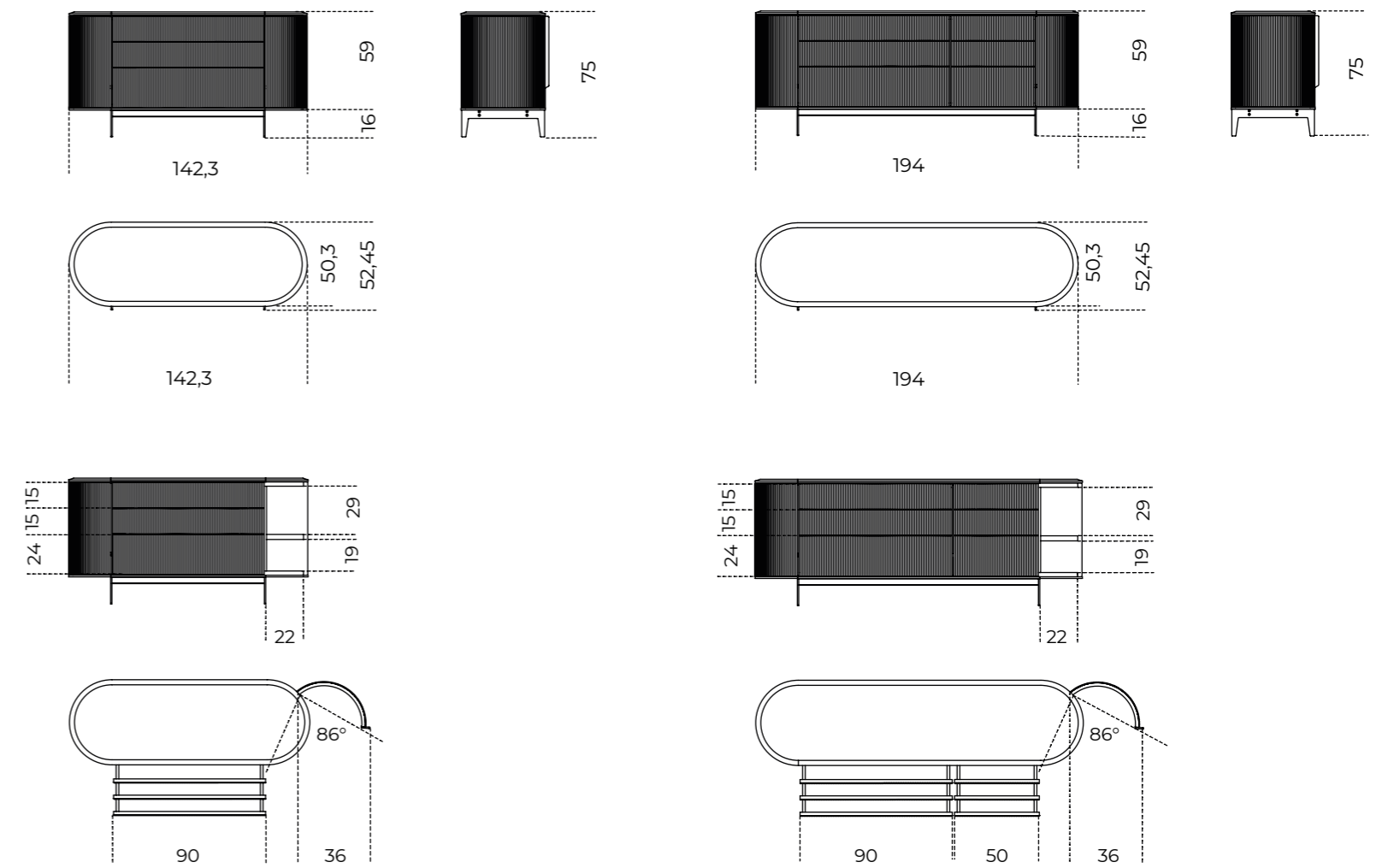

**Holly Comò** | Pinuccio Borgonovo, 2020

Product information / p. 496

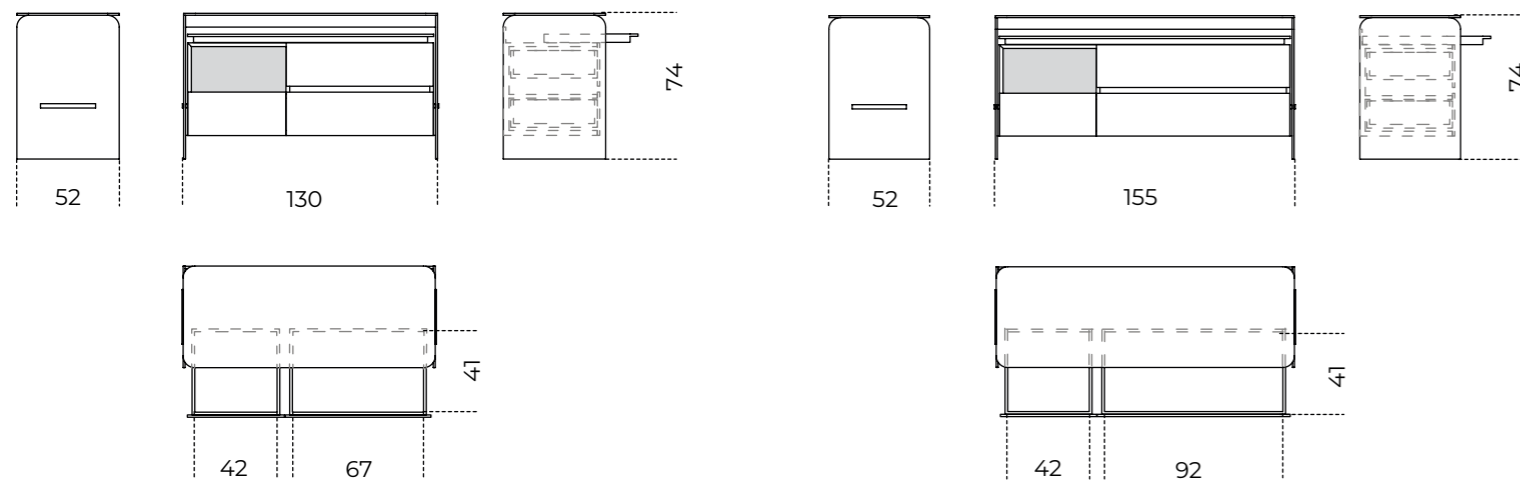

**Stami Night** | Studiopepe, 2023

[Product information / p. 502](#)

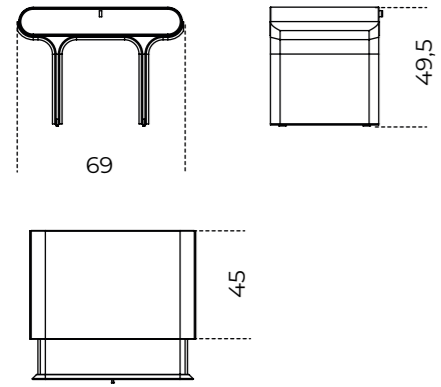

**Twelve C** | Massimo Castagna, 2018

[Product information / p. 504](#)

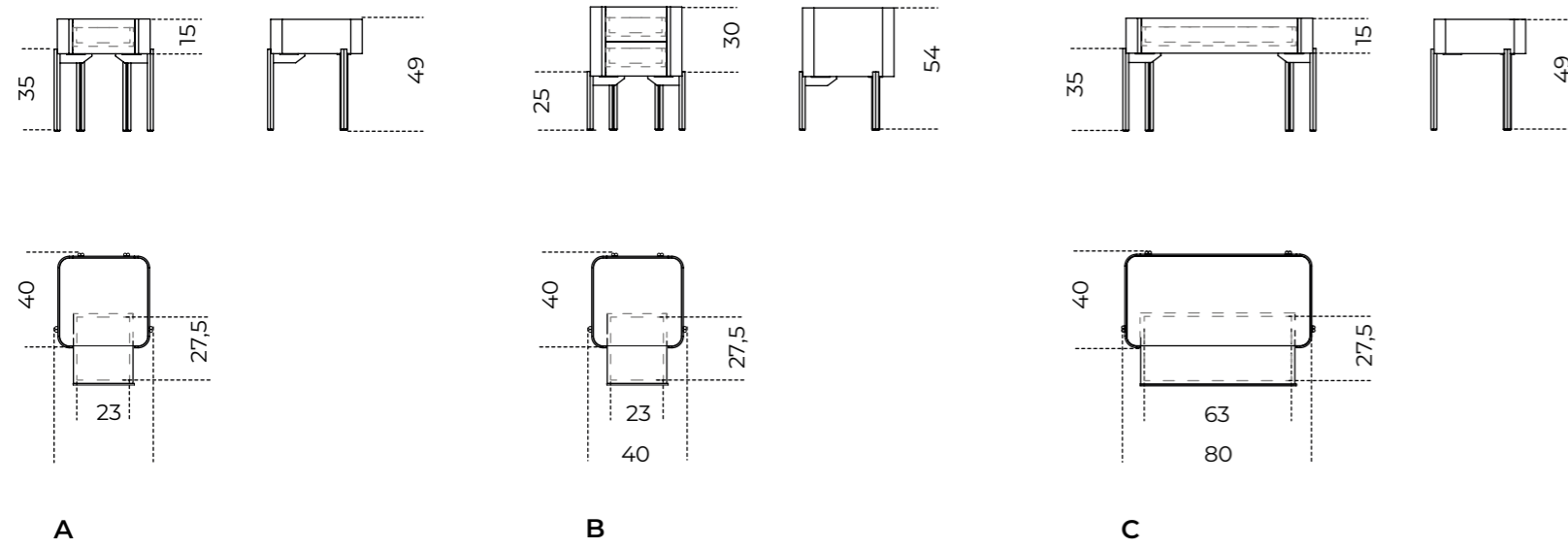



## **12** Scrittoi e Vanity / Desks and Vanity

- 514 Lui
- 516 President Junior/President Senior
- 518 President Junior/President Senior 50<sup>th</sup>
- 520 Prism Desk
- 522 Selene
- 524 Sensei Desk
- 526 Soho
- 528 Stami
- 530 Tama Secrétaire
- 532 Venere
  
- 534 Informazioni tecniche/  
Technical informations

# Lui

Paolo Maria Fumagalli / 2010

Scrivania con piano superiore in cristallo trasparente o extralight temperato 12mm con struttura in acciaio inox lucido o satinato. Disponibile anche in cristallo "grigio Italia" temperato 12mm con struttura in metallo laccato color brunito. Ripiano inferiore e cassetti in frassino naturale, tinto wengè, tinto tabacco, tinto "Pure" bianco o laccato nero a poro aperto. Su richiesta tappetino in pelle scamosciata nei colori del campionario.

Desk with clear or extralight 12mm tempered crystal top with polished or satin-finished stainless steel frame. Also available in 12mm tempered "grigio Italia" glass with burnished lacquered metal frame. Bottom shelf and drawers in natural, wenge-stained, tobacco-stained, white "Pure" stained or open-pore black lacquered ash. On request suede leather mat in the colors of the sample book.

## NOTE TECNICHE SUI MATERIALI

**PELLE SCAMOSCIATA** | Tutto il vissuto del manto resta completamente visibile e si manifesta in venature, graffi, possibili variazioni cromatiche, naturali arricciature, che conferiscono a questa pelle una preziosità unica.

## TECHNICAL INFORMATION ON THE MATERIALS

**SUEDE** | The layer's past is fully visible and is expressed in the grain, possible colour variations, and natural crimping, which give this leather a unique precious feel.



### Cm

140 x 65 x 75  
160 x 65 x 75  
180 x 65 x 75

### Inches

55¼" x 25¾" x 29¾"  
63" x 25¾" x 29¾"  
71" x 25¾" x 29¾"

[For technical drawing / p. 536](#)

[Pricelist 2023 / p. 230](#)

## PIANO SUPERIORE E STRUTTURA/ TOP AND STRUCTURE



Cristallo trasparente/  
Acciaio inox lucido  
Transparent glass/  
Bright stainless steel



Cristallo trasparente/  
Acciaio inox satinato  
Transparent glass/  
Satin stainless steel



Cristallo extralight/  
Acciaio inox lucido  
Extralight glass/  
Bright stainless steel



Cristallo extralight/  
Acciaio inox satinato  
Extralight glass/  
Satin stainless steel

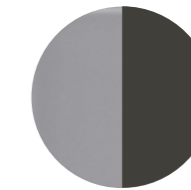

Cristallo "grigio Italia"/  
Metallo laccato color brunito  
"Grigio Italia" glass/  
Burnished lacquered metal

## PIANO INFERIORE E CASSETTI/ BOTTOM SHELF AND DRAWERS



Frassino naturale  
Natural ash



Frassino tinto wengè a  
poro aperto  
Wengè stained open pore  
ash



Frassino tinto tabacco a  
poro aperto  
Tobacco stained open pore  
ash



Frassino tinto "Pure"  
bianco a poro aperto  
"Pure" white open pore  
stained ash

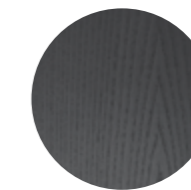

Frassino laccato  
nero a poro aperto  
Black open pore  
lacquered ash

## TAPPETINO/PAD



Pelle scamosciata  
nei colori del campionario  
Suede as per samples.

### ▲ LUI

Struttura in acciaio inox lucido / Piano superiore in cristallo trasparente / Piano inferiore e cassetti in frassino naturale  
Bright stainless steel structure / Transparent glass top / Natural ash bottom shelf and drawers



▲ **PRESIDENT SENIOR**  
Struttura in cristallo trasparente temperato / Parti metalliche in acciaio inox lucido  
Transparent tempered glass structure / Bright stainless steel metal parts

# President Junior/President Senior

Studio G&R / 1971

Scrivania in cristallo trasparente, extralight o "grigio Italia" temperato 10mm (President Junior) o 12mm (President Senior). Parti metalliche in acciaio inox lucido o satinato. Disponibili anche in ottone lucido, ottone satinato o laccato bianco o nero goffrato.

Desk with 10mm (President Junior) or 12mm (President Senior) transparent, extralight or smoked "grigio Italia" tempered glass. Bright or satin stainless steel metal parts. Also available bright brass, satin brass or embossed white or black lacquered metal parts.



**Cm**  
**President Junior**  
172 x 80 x 74

**President Senior**  
210 x 106 x 74

**Inches**  
**President Junior**  
67¾" x 31½" x 29¼"

**President Senior**  
82¾" x 41¾" x 29¼"

For technical drawing / p. 536

Pricelist 2023 / p. 231

Homescapes, embracing beauty / p. 41, 42-44

## STRUTTURA/STRUCTURE



**Cristallo trasparente**  
Transparent glass



**Cristallo extralight**  
Extralight glass

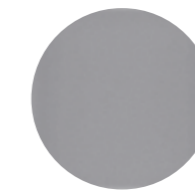

**Cristallo "grigio Italia"**  
Smoked "grigio Italia" glass

## PARTI METALLICHE/ METAL PARTS

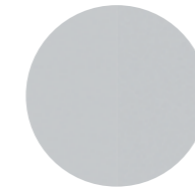

**Acciaio inox lucido**  
Bright stainless steel

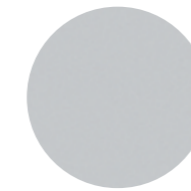

**Acciaio inox satinato**  
Satin stainless steel

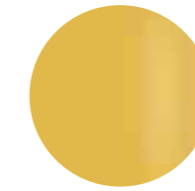

**Ottone lucido**  
Bright brass



**Ottone satinato**  
Satin brass

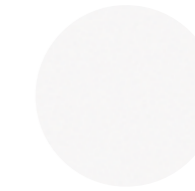

**Laccato bianco goffrato**  
Embossed white lacquered



**Laccato nero goffrato**  
Embossed black lacquered



▲ **PRESIDENT JUNIOR**  
Struttura in cristallo extralight temperato "Crisscross gold" / Parti metalliche in "Crisscross gold"  
"Crisscross gold extralight tempered glass structure / "Crisscross gold" metal parts

# President Junior/President Senior <sup>50<sup>th</sup> Anniversary</sup>

Studio G&R/Silvia Gallotti, 2021

Scrivania in cristallo extralight temperato 10mm (President Junior) o 12mm (President Senior) verniciato nella finitura esclusiva "crisscross gold". Parti metalliche verniciate nella finitura esclusiva "crisscross gold". Collezione in edizione numerata.

#### NOTE TECNICHE SUI MATERIALI

**CRISTALLO** | Le finiture esclusive, risultato della lavorazione manuale realizzata sul cristallo, possono presentare macchie e striature, oltre a differenze cromatiche. Tali disomogeneità sono caratteristiche che non devono essere considerate difetti ma elementi distintivi che esaltano la bellezza e la peculiarità del pezzo unico.

Desk with 10mm (President Junior) or 12mm (President Senior) extralight tempered glass decorated with the exclusive "crisscross gold" finish. Metal parts painted with the exclusive finish "crisscross gold". Collection in numbered edition.

#### TECHNICAL INFORMATION ON THE MATERIALS

**GLASS** | Artisanal and exclusive finishes that are obtained from the oxidation of silver, gold and copper leaves may show marks and spots, as well as variations in colour. These differences are inevitable and should not be considered imperfections but evidence of the hand-crafted process. They enhance the beauty and distinctiveness of a unique piece.



**Cm**  
**President Junior**  
172 x 80 x 74

**President Senior**  
210 x 106 x 74

**Inches**  
**President Junior**  
67<sup>3</sup>/<sub>4</sub>" x 31<sup>1</sup>/<sub>2</sub>" x 29<sup>1</sup>/<sub>4</sub>"

**President Senior**  
82<sup>3</sup>/<sub>4</sub>" x 41<sup>3</sup>/<sub>4</sub>" x 29<sup>1</sup>/<sub>4</sub>"

For technical drawing / p. 536

Pricelist 2023 / p. 232  
Homescapes, intimate portraits / p. 33, 35-37

#### PIANO E SPALLE/ TOP AND SIDES

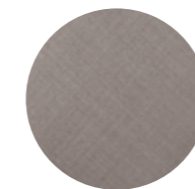

Cristallo verniciato  
"crisscross gold"  
"Crisscross gold"  
painted glass

#### PARTI METALLICHE/ METAL PARTS

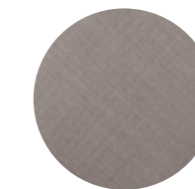

Metallo verniciato  
"crisscross gold"  
"Crisscross gold"  
painted metal



▲ **PRISM DESK**  
Struttura in Palissandro India intarsiato con alluminio naturale  
India Rosewood and natural aluminium structure

# Prism Desk

David/Nicolas /2019

Scrivania in legno Noce "Colore" Frisé intarsiato con alluminio naturale o Palissandro India intarsiato con alluminio naturale. Basi dotate di due ripiani in cristallo extralight temperato 8mm.

Wooden desk with marquetry of "Colore" Frisé Walnut and natural aluminium or India Rosewood and natural aluminium. Bases provided with two 8mm thick extralight tempered internal shelves.

! Il legno è un materiale vivo che subisce un naturale processo di ossidazione che può causare cambiamenti cromatici. Venature e tonalità di colore differenti delle lastre non sono da considerarsi come difetti, ma caratteristiche che esaltano l'unicità del materiale.

! Wood is a living material and the natural oxidation process can cause chromatic changes. Different grain and colour shades of the wooden slabs are not to be considered as defects, but characteristics that enhance the uniqueness of the material.

## NOTE TECNICHE SUI MATERIALI

**INTARSIO** | L'intarsio è una tecnica di lavorazione artigianale utilizzata per ottenere un particolare disegno e si realizza accostando elementi di materiali differenti (come legno e alluminio) oppure dello stesso materiale. Questa lavorazione rende il prodotto unico ed esclusivo. Le eventuali variazioni cromatiche e di venatura del legno sono da considerarsi caratteristiche del materiale stesso e non possono essere controllate.

## TECHNICAL INFORMATION ON THE MATERIALS

**INLAY** | Inlay is an artisanal technique used to obtain a particular design and is made by combining elements of different materials (such as wood and aluminium) or of the same material. This process makes the product unique and exclusive. Any colour and grain variations of the wood are to be considered as characteristics of the material itself and cannot be controlled.



**Cm**  
210 x 93,5 x 74  
230 x 93,5 x 74

**Inches**  
83¼" x 37" x 29¼"  
90¾" x 37" x 29¼"

[For technical drawing / p. 537](#)

[Pricelist 2023 / p. 233](#)  
[Homescapes, embracing beauty / p. 48](#)

## STRUTTURA/STRUCTURE



Legno Noce "Colore" Frisé e alluminio naturale  
"Colore" Frisé Walnut and aluminium

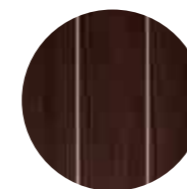

Legno palissandro India e alluminio naturale  
India rosewood and aluminium

## RIPIANI/INSIDE SHELVES



Cristallo extralight  
Extralight glass

# Selene

Pietro Russo / 2016

Scrittoio-vanity in Taba Frisé bianco e Tanganika nero. Cassetti laterali push-pull con apertura rotante a 90° e cassetto centrale con apertura frontale. Parti metalliche laccate ottone satinato. Specchio extralight in 6mm bisellato. Dotato di Luce LED. Parti metalliche laccate ottone satinato e base in marmo levigato opaco Nero Marquinia.

Vanity desk in Taba Frisé white wood and Tanganika black wood. Push-pull side drawers with 90° rotating opening and front opening central drawer. Satin brass lacquered metal parts. 6mm bevelled extralight mirror. With LED light. Satin brass lacquered metal parts and honed mat Nero Marquinia marble base.

! Nella versione senza specchio il piano viene fornito con ciotola in ottone satinato.

! In the version without mirror the wooden top is supplied with satin brass tray.

## NOTE TECNICHE SUI MATERIALI

**MARMO** | Il marmo è un materiale naturale di origine sedimentaria che può presentare particolarità come venature, lievi irregolarità superficiali, colorazioni differenti e cristallizzazioni. Queste peculiarità sono da attribuirsi alla naturalezza del materiale e non sono da considerarsi difetti ma caratteristiche tipiche del marmo. Ogni prodotto risulterà unico, esclusivo e non replicabile.

**INTARSIO** | L'intarsio è una tecnica di lavorazione artigianale utilizzata per ottenere un particolare disegno e si realizza accostando elementi di materiali differenti (come legno e alluminio) oppure dello stesso materiale. Questa lavorazione rende il prodotto unico ed esclusivo. Le eventuali variazioni cromatiche e di venatura del legno sono da considerarsi caratteristiche del materiale stesso e non possono essere controllate.

## TECHNICAL INFORMATION ON THE MATERIALS

**MARBLE** | The marble is a natural material of sedimentary origin that can present particularities such as veins, slight surface irregularities, different colors and crystallizations. These peculiarities are to be attributed to the naturalness of the material and are not to be considered defects but typical characteristics of marble. Each product will be unique, exclusive and non-replicable.

**INLAY** | Inlay is an artisanal technique used to obtain a particular design and is made by combining elements of different materials (such as wood and aluminium) or of the same material. This process makes the product unique and exclusive. Any colour and grain variations of the wood are to be considered as characteristics of the material itself and cannot be controlled.



### Cm

Versione con specchio  
130 x 50 x 143

Versione senza specchio  
130 x 50 x 78

### Inches

Version with mirror  
51¼" x 19¾" x 56½"

Version without mirror  
51¼" x 19¾" x 30¾"

[For technical drawing / p. 537](#)

[Pricelist 2023 / p. 234](#)  
[Homescapes, embracing beauty / p. 53](#)

### STRUTTURA/STRUCTURE



Taba Frisé bianco/  
Tanganika nero  
Taba Frisé white wood/  
Tanganika black wood

### PARTI METALLICHE/ METAL PARTS



Laccato ottone satinato  
Satin brass lacquered  
metal

### SPECCHIO/MIRROR



Specchio extralight  
Extralight mirror

### PARTI METALLICHE SPECCHIO/MIRROR METAL PARTS



Ottone satinato  
Satin brass

### BASE SPECCHIO / MIRROR BASE



Marmo levigato opaco  
Nero Marquinia  
Honed mat  
Nero Marquinia marble

### LUCE/LIGHT

15 watt  
108 lm/w  
3000k

# Sensei Desk

Tollgard + Castellani / 2016

Scrivania con struttura in metallo e piano in legno laccato "deep black". Schienale in frassino tinto nero a poro aperto. In appoggio sul top in legno, piano in cristallo 12mm molato a mezzo toro nella finitura esclusiva "Rosso Marte" oppure retroverniciato brillante nei colori del campionario. Disponibile anche piano in marmo 20mm Ceppo di Gré® spazzolato, Arabescato Orobico Rosso satinato, Bianco Carrara Gioia satinato oppure Dover White satinato. Piano disponibile anche rivestito in pelle fard nei colori del campionario. Su richiesta blocco cassette in frassino tinto nero poro aperto con vassoi rimovibili in metallo rivestito in pelle fard nei colori del campionario.

## NOTE TECNICHE SUI MATERIALI

**MARMO** | Il marmo è un materiale naturale di origine sedimentaria che può presentare particolarità come venature, lievi irregolarità superficiali, colorazioni differenti e cristallizzazioni. Queste peculiarità sono da attribuirsi alla naturalità del materiale e non sono da considerarsi difetti ma caratteristiche tipiche del marmo. Ogni prodotto risulterà unico, esclusivo e non replicabile. I nostri marmi vengono trattati con un prodotto idrorepellente che permette una maggiore protezione della superficie stessa, aumentando l'impermeabilità. Questo trattamento non esclude la vulnerabilità del marmo alle sostanze acide.

Desk with "deep black" lacquered metal structure and wooden top. Black open pore stained ash shelf and back. Resting on the wooden top, 12mm glass top with half bull-nose grinding in the exclusive finish "Rosso Marte" or painted as per samples in the bright version. Also available with 20mm brushed Ceppo di Gré®, satin Arabescato Orobico Rosso, satin Bianco Carrara Gioia or satin Dover White top. Top available also covered by leather Fard as per samples. On request, black open pore stained ash drawer unit with removable metal trays covered by leather Fard as per samples.

## TECHNICAL INFORMATION ON THE MATERIALS

**MARBLE** | The marble is a natural material of sedimentary origin that can present particularities such as veins, slight surface irregularities, different colors and crystallizations. These peculiarities are to be attributed to the naturalness of the material and are not to be considered defects but typical characteristics of marble. Each product will be unique, exclusive and non-replicable. Our marbles are treated with water-repellent products which affords greater protection to the surface of the marble, improving its impermeability. This treatment doesn't exclude the vulnerability of the marble to acid substances.



## Cm

### Piano in cristallo

160 x 75 x 75,3  
180 x 75 x 75,3  
200 x 75 x 75,3

### Piano in marmo

160 x 75 x 75,3  
180 x 75 x 75,3  
200 x 75 x 75,3

### Piano in pelle Fard

160 x 75 x 75,3  
180 x 75 x 75,3  
200 x 75 x 75,3

### Blocco cassette

35 x 25

## Inches

### Glass top

63" x 29 3/4" x 29 3/4"  
71" x 29 3/4" x 31 1/2"  
78 3/4" x 29 3/4" x 29 3/4"

### Marble top

63" x 29 3/4" x 29 3/4"  
71" x 29 3/4" x 31 1/2"  
78 3/4" x 29 3/4" x 29 3/4"

### Fard top

63" x 29 3/4" x 29 3/4"  
71" x 29 3/4" x 31 1/2"  
78 3/4" x 29 3/4" x 29 3/4"

### Drawer unit

14" x 10"

For technical drawing / p. 537

## STRUTTURA/STRUCTURE



Metallo/legno laccato  
"deep black"  
"deep black" lacquered  
metal/wood

## PIANO/TOP



Cristallo "Rosso Marte"  
"Rosso Marte" glass



Sample box

Cristallo brillante  
nei colori del campionario  
Bright glass version  
as per samples



Ceppo di Gré® spazzolato  
Brushed Ceppi di Gré®



Marmo Arabescato  
Orobico Rosso satinato  
Arabescato Orobico  
Rosso satin marble

## BLOCCO CASSETTI/ DRAWER UNIT

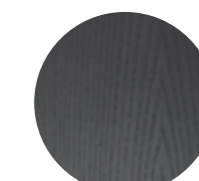

Frassino tinto  
nero poro aperto  
Black open pore  
stained ash

## SCHIENALE/BACK

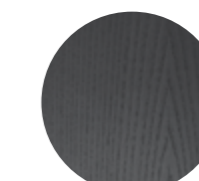

Frassino tinto  
nero a poro aperto  
Black open pore  
stained ash

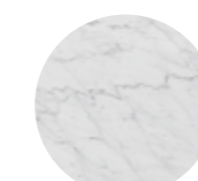

Marmo spazzolato  
Bianco Carrara Gioia  
Brushed Bianco Carrara  
Gioia marble

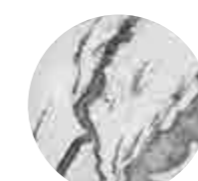

Marmo satinato  
Dover white  
Satin Dover white marble



Sample box  
COVERS

Rivestito in pelle fard  
nei colori del campionario  
Covered leather fard  
as per samples



Sample box  
COVERS

Metallo rivestito in pelle fard  
nei colori del campionario  
Metal covered leather fard  
as per samples

\* SELENE

Struttura in Taba Frise bianco e Tanganka nero / Structure in extralight con base in marmo nero Marquinia  
Taba Frise white wood and Tanganka black wood structure / Extralight mirror with Nero Marquinia marble base



▲ SOHO  
Struttura in frassino tinto nero poro aperto / Piano in marmo Calacatta Vagli Oro / Ottone lucido  
Black open pore lacquered ash structure / Calacatta Vagli Oro marble top / Bright brass metal part

# Soho

Carlo Colombo / 2017

Scrittoio in massello di frassino tinto nero a poro aperto con fascia zigrinata realizzata a mano. Piano in marmo lucido naturale Calacatta Vagli Oro oppure in cristallo 12mm retroverniciato liquirizia nella versione brillante o satinata. Dotato di due cassetti ad estrazione totale, con fondo in pelle scamosciata Grey 020. Parti metalliche in ottone lucido. Su richiesta vaschette portaoggetti rivestite in pelle scamosciata grey 020.

! Il legno massello è molto sensibile alla luce, il posizionamento vicino a sorgenti di luce naturale ne compromette la colorazione e la stabilità. Un'elevata variazione della temperatura e umidità dell'aria può provocare la comparsa di microfratture e leggere variazioni.

#### NOTE TECNICHE SUI MATERIALI

**MARMO** | Il marmo è un materiale naturale di origine sedimentaria che può presentare particolarità come venature, lievi irregolarità superficiali, colorazioni differenti e cristallizzazioni. Queste peculiarità sono da attribuirsi alla naturalezza del materiale e non sono da considerarsi difetti ma caratteristiche tipiche del marmo. Ogni prodotto risulterà unico, esclusivo e non replicabile. I nostri marmi vengono trattati con un prodotto idrorepellente che permette una maggiore protezione della superficie stessa, aumentando l'impermeabilità. Questo trattamento non esclude la vulnerabilità del marmo alle sostanze acide.

Desk in black open pore stained solid ash with hand-knurled sides. Natural polished Calacatta Vagli Oro marble or 12mm liquorice painted glass top, in the bright or satin version. Supplied with two drawers with suede Grey 020 bottom. Bright brass metal parts. On request, small boxes covered by suede Grey 020.

! Solid wood is very light-sensitive, placing it near natural light sources may compromise its colour and stability. Considerable differences in air temperature and humidity may cause microfractures and slight variations.

#### TECHNICAL INFORMATION ON THE MATERIALS

**MARBLE** | The marble is a natural material of sedimentary origin that can present particularities such as veins, slight surface irregularities, different colors and crystallizations. These peculiarities are to be attributed to the naturalness of the material and are not to be considered defects but typical characteristics of marble. Each product will be unique, exclusive and non-replicable. Our marbles are treated with water-repellent products which affords greater protection to the surface of the marble, improving its impermeability. This treatment doesn't exclude the vulnerability of the marble to acid substances.



#### Cm

130 x 55 x 84

Vaschette portaoggetti

13 x 13 x 4

#### Inches

51¼" x 21¾" x 33¼"

Small boxes

5¼" x 5¼" x 1¼"

For technical drawing / p. 538

Pricelist 2023 / p. 235

Homescapes, intimate portraits/ p. 99

#### STRUTTURA/STRUCTURE

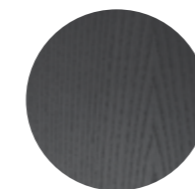

Frassino tinto  
nero a poro aperto  
Black open pore  
stained ash

#### PIANO/TOP



Marmo lucido naturale  
Calacatta Vagli Oro  
Natural polished  
Calacatta Vagli Oro marble

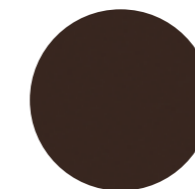

Cristallo retroverniciato  
liquirizia brillante  
Bright liquorice  
painted glass

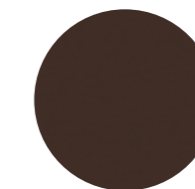

Cristallo retroverniciato  
liquirizia satinato  
Satin liquorice  
painted glass

#### FONDO CASSETTI/ DRAWERS BOTTOM



Pelle scamosciata Grey 020  
Suede Grey 020

#### PARTI METALLICHE/ METAL PARTS

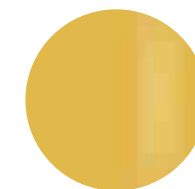

Ottone lucido  
Bright brass





• STAMI  
Base in frassino curvato tinto nero poro aperto / Struttura rivestito in suede grey 058  
Curved black open pore stained ash base / Covered by suede grey 058 structure

# Stami

Studiopepe/2022

Desk e vanity con base in frassino curvato tinto nero a poro aperto e dettagli in ottone lucido. Struttura in legno con rivestimento in pelle o pelle scamosciata nei colori del campionario. Piano apribile a ribalta in legno tinto nero poro aperto e vano interno dotato di sottomano in pelle o pelle scamosciata coordinata con il rivestimento esterno. Piano a ribalta con lavagna magnetica (desk) o con specchio (vanity). Disponibile anche versione con cassetti laterali.

! Per la realizzazione di elementi con rivestimento in pelle sono necessarie cuciture aggiuntive rispetto gli elementi con rivestimento in tessuto.

Desk and vanity desk with curved black open pore stained ash base and bright brass details. Wooden structure covered by leather or suede as per samples. Black open pore stained wooden opening top and internal compartment equipped with leather or suede pad coordinated with the external upholstery. Opening top with magnetic board (desk) or with mirror (vanity). Also available version with side drawers.

! Additional stitching is required for elements with leather upholstery compared to elements with fabric upholstery.



**Cm**  
**Scrivania**  
140 x 60 x 76  
**Vanity**  
140 x 60 x 76

**Porta-oggetti per vanity desk**  
65 x 34 x 2

**Inches**  
**Desk**  
55 1/4" x 23 3/4" x 30"  
**Vanity**  
55 1/4" x 23 3/4" x 30"

**Organiser for vanity desk**  
25 3/4" x 13 1/2" x 1"

For technical drawing / p. 538

Pricelist 2023 / p. 236  
Homescapes, intimate portraits / p. 99  
Homescapes, gentle attitude / pp. 54, 57

RIVESTIMENTO ESTERNO/  
EXTERNAL UPHOLSTERY



Pelle/pelle scamosciata  
nei colori del campionario  
Leather/suede as per  
samples.

BASE/BASE

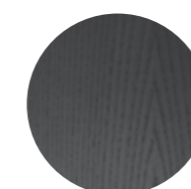

Frassino curvato  
tinto a nero poro aperto  
Curved black open pore  
stained ash

DETTAGLI/ DETAILS



Ottone lucido  
Bright brass

PIANO APRIBILE  
E VANO INTERNO/  
OPENING TOP  
AND INTERNAL COMPARTMENT

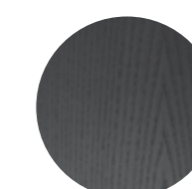

Legno tinto nero poro aperto  
Black open pore stained wood

SOTTOMANO/  
WRITING PAD



Pelle/pelle scamosciata  
nei colori del campionario  
Leather/suede as per  
samples.

# Tama Secrétaire

Carlo Colombo / 2016

Scrittoio con anta a ribalta in frassino tinto nero a poro aperto. Parti metalliche laccate ottone satinato. Top e schienale interno in cristallo 6mm retroverniciato liquirizia brillante. Lo schienale riporta incisione "a rombi". Interno ribalta e scatole portaoggetti rivestiti in pelle scamosciata Grey 058. Dotata di luce interna LED attivata da un sensore all'apertura dell'anta.

Writing desk with flap door in black open pore stained ash. Satin brass lacquered metal parts. 6mm bright liquorice painted glass top and inside back. Rhomboidal engraved pattern on the inside glass back. Inside part of flap door and small boxes covered by suede Grey 058. Supplied with inside LED light turned on by sensor as door is opened.



▲ TAMA SECRÉTAIRE  
Struttura in frassino tinto nero poro aperto / Parti metalliche in ottone lucido / Top in cristallo retroverniciato liquirizia brillante  
Black open pore lacquered ash structure / Bright brass metal parts / Bright liquorice painted glass top



**Cm**  
120 x 36 x 110  
140 x 36 x 110

**Inches**  
47¼" x 14¼" x 43½"  
55¼" x 14¼" x 43½"

[For technical drawing / p. 539](#)

[Pricelist 2023 / p. 237](#)

STRUTTURA/STRUCTURE

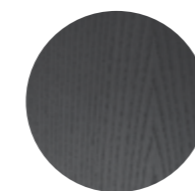

Frassino tinto  
nero a poro aperto  
Black open pore  
stained ash

PARTI METALLICHE



Ottone satinato  
Satin brass

PIANO/TOP

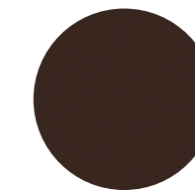

Cristallo retroverniciato  
liquirizia brillante  
Bright liquorice  
painted glass

SCHIENALE INTERNO/  
INSIDE BACK



Cristallo retroverniciato  
liquirizia brillante con  
incisione a rombi  
Bright liquorice painted  
glass with rhomboidal  
engraved pattern

INTERNO RIBALTA E  
PORTAOGGETTI/ INSIDE  
FLAP DOOR AND BOXES



Pelle scamosciata Grey 058  
Suede Grey 058

LUCE INTERNA/  
INSIDE LIGHT

LED 15W  
108 lm  
3000K  
Cable lenght: 1,5mt



#### ▲ VENERE

Struttura in cristallo Champagne satinato e metallo laccato color brunito / Specchio bifacciale orientabile / Vaschette porta oggetti in pelle scamosciata Sand 012.  
Satin champagne glass and burnished lacquered metal structure / Rotating double face mirror / Small boxes covered by suede Sand 012.

# Venere

Carlo Colombo / 2013

Scrittoio-vanity in legno rivestito in cristallo 6mm temperato e con mensola in appoggio in cristallo 10mm temperato, entrambi retroverniciati nei colori del campionario, nella versione brillante o satinata. Specchio bifacciale diam. 50cm, orientabile (360°).  
Su richiesta inserto con specchio ingranditore. Cassetti in legno laccato effetto tessuto color castagna. Struttura in metallo laccato color brunito. Vaschette porta oggetti in metallo rivestito in pelle scamosciata Sand 012.  
Lo specchio è previsto sul lato sinistro.

Vanity wooden desk covered by 6mm tempered glass and 10mm tempered shelf, both painted as per samples in the bright or satin version. Rotating (360°) double face mirror diam. 50cm.  
Magnifying mirrored insert, on request. Chestnut with "fabric" touch effect lacquered drawers. Burnished lacquered metal structure. Small boxes in metal covered by suede Sand 012.  
The mirror will be on the left side.



#### Cm

**Versione con specchio**  
124 x 60 x 136  
144 x 60 x 136

**Versione senza specchio**  
124 x 60 x 86  
144 x 60 x 86

#### Inches

**Version with mirror**  
49" x 23 3/4" x 53 3/4"  
56 3/4" x 23 3/4" x 53 3/4"

**Version without mirror**  
49" x 23 3/4" x 34"  
56 3/4" x 23 3/4" x 34"

[For technical drawing / p. 539](#)

[Pricelist 2023 / p. 238](#)  
[Homescapes, intimate portraits / p. 50](#)

#### STRUTTURA/STRUCTURE



Sample box

**Cristallo brillante/satinato nei colori del campionario**  
Glass bright/satin version as per samples

#### PARTI METALLICHE/ METAL PARTS



**Metallo laccato color brunito**  
Burnished lacquered metal

#### CASSETTI/DRAWERS

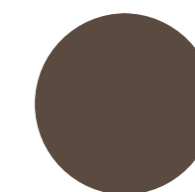

**Legno laccato effetto tessuto color castagna**  
Chestnut with "fabric" touch effect lacquered

#### PORTAOGGETTI/BOXES

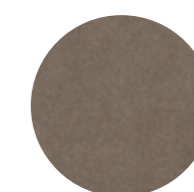

**Pelle scamosciata Sand 012**  
Suede Sand 012

# 12

**Scrittoi e Vanity / Desks and Vanity**  
**TECHNICAL MODULE**

**Luì** | Paolo Maria Fumagalli, 2010

Product information / p. 514

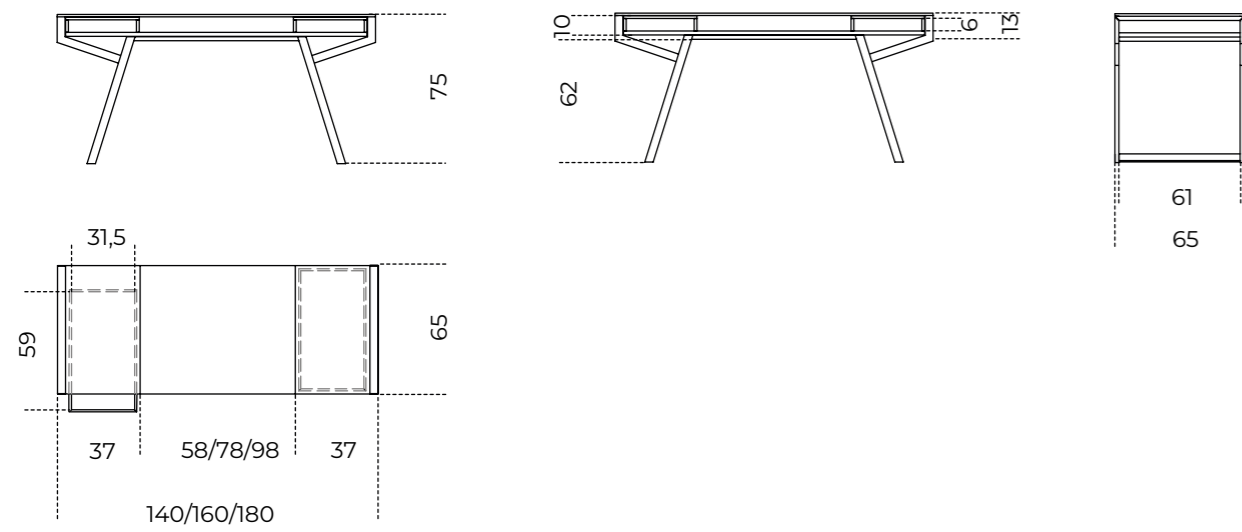

**Prism Desk** | David/Nicolas, 2019

Product information / p. 520

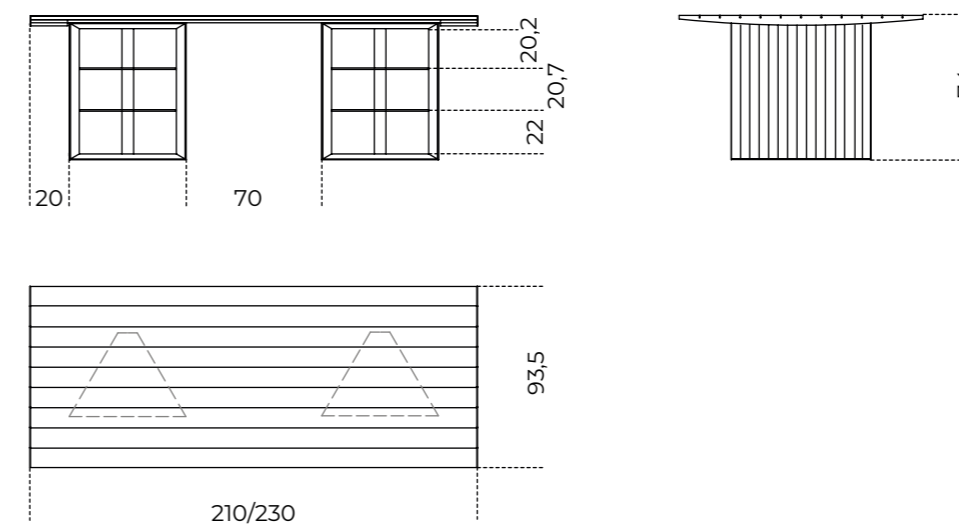

**President Junior / President Senior** | Studio G&R, 1971

Product information / p. 516

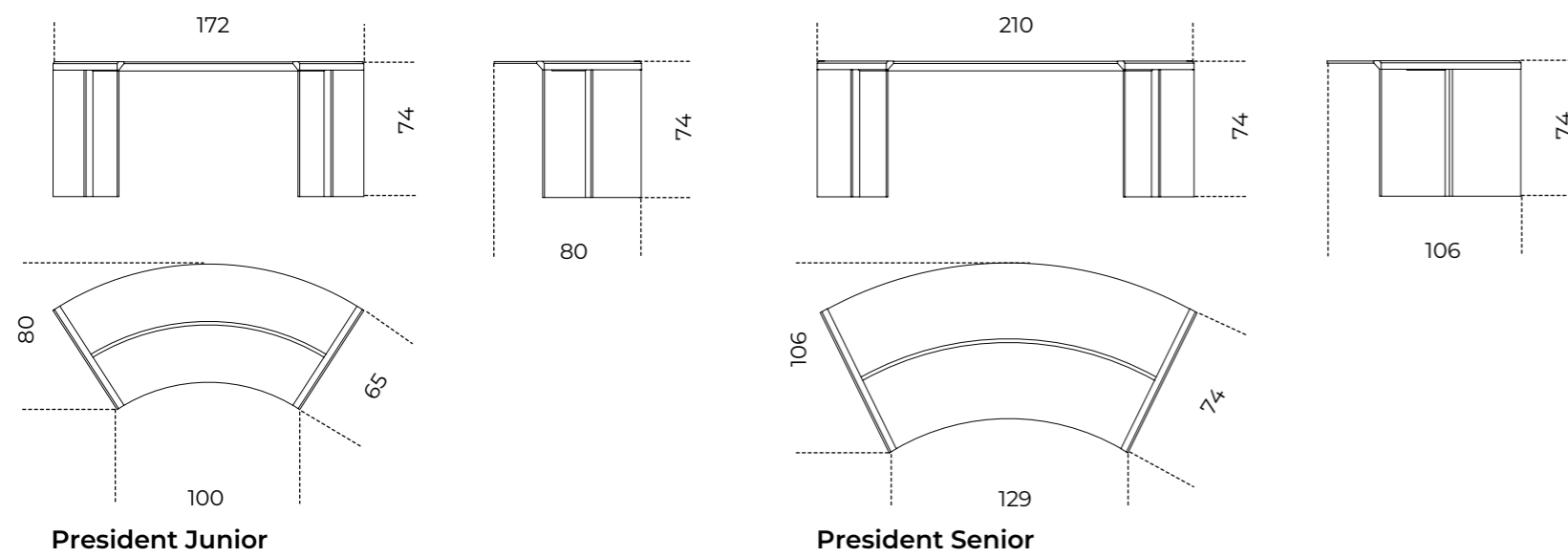

**Selene** | Pietro Russo, 2016

Product information / p. 522

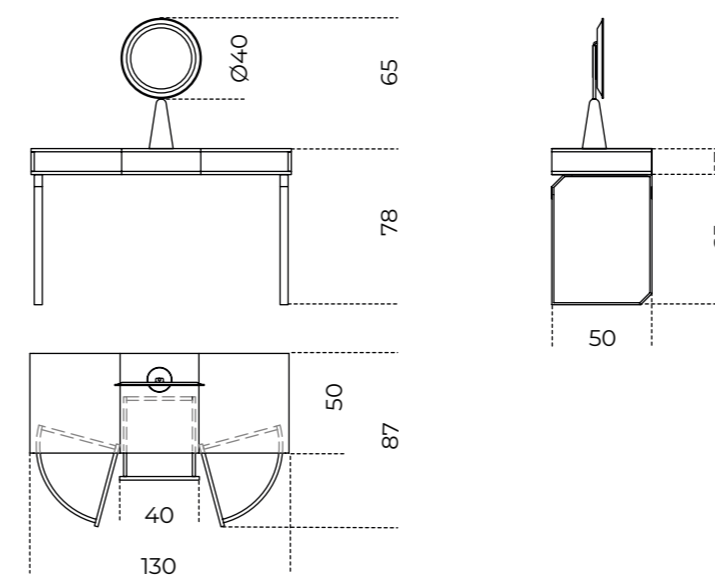

**President Junior 50th / President Senior 50th** | Studio G&R, 2021

Product information / p. 518

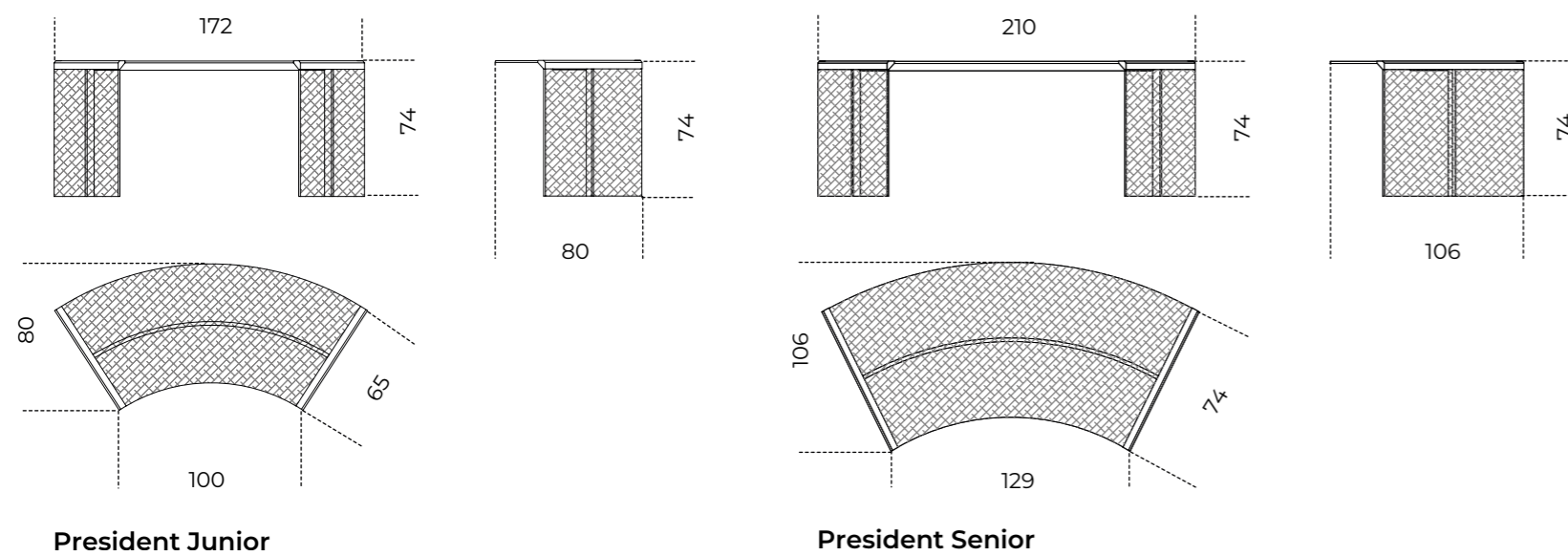

**Sensei Desk** | Tollgard + Castellani, 2024

Product information / p. 524

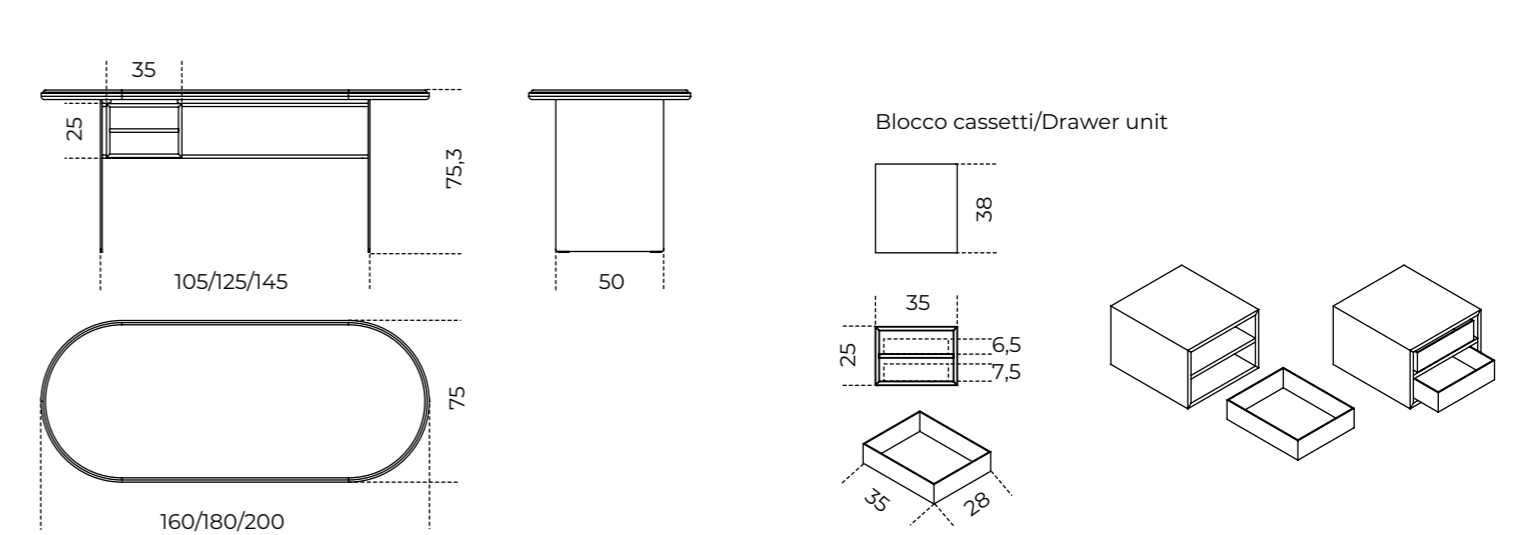

**Soho** | Carlo Colombo, 2017

Product information / p. 526

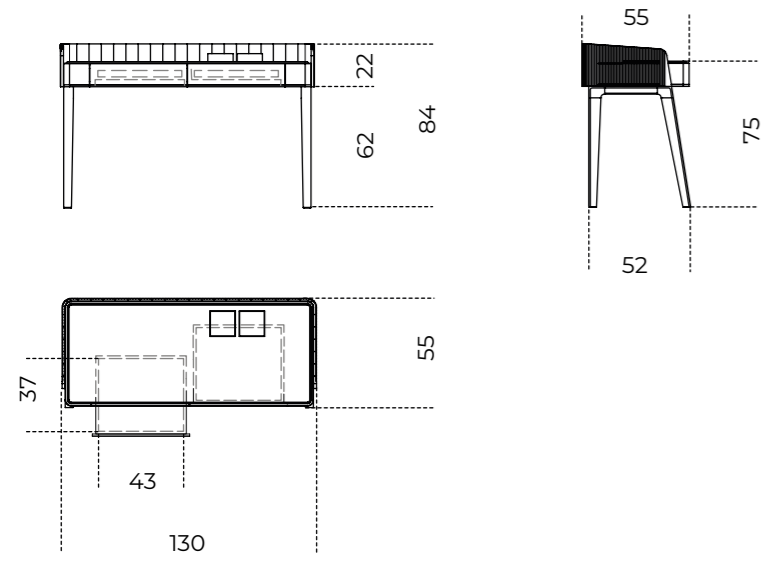

**Tama Secrétaire** | Carlo Colombo, 2016

Product information / p. 530

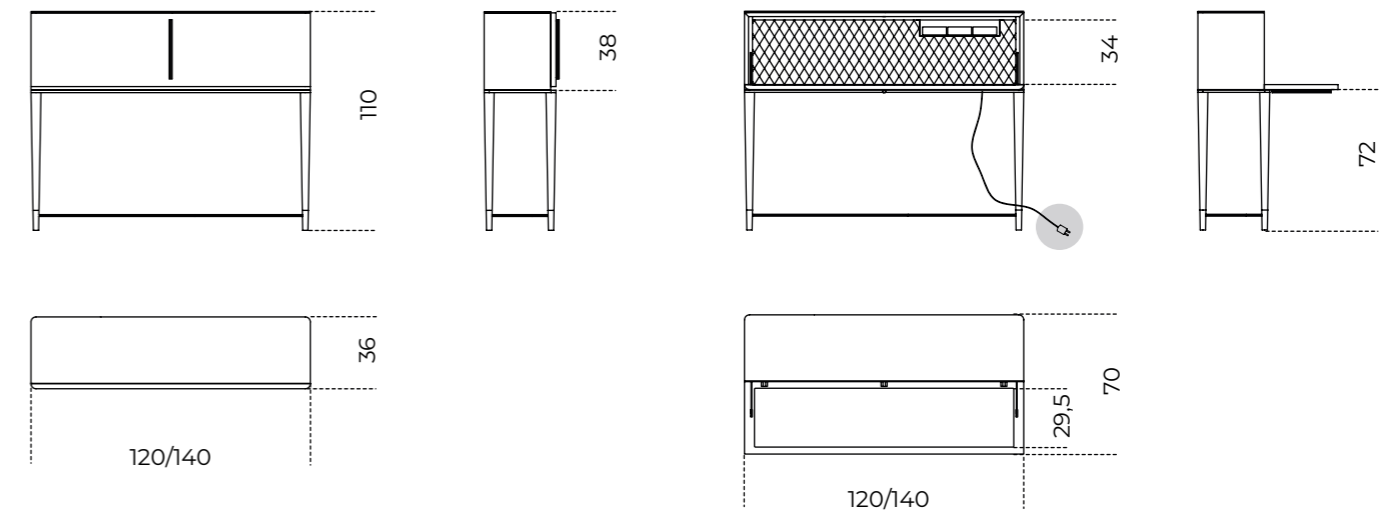

**Stami** | Studiopepe, 2022

Product information / p. 528

**Versione desk senza cassetti**  
Desk version without drawers

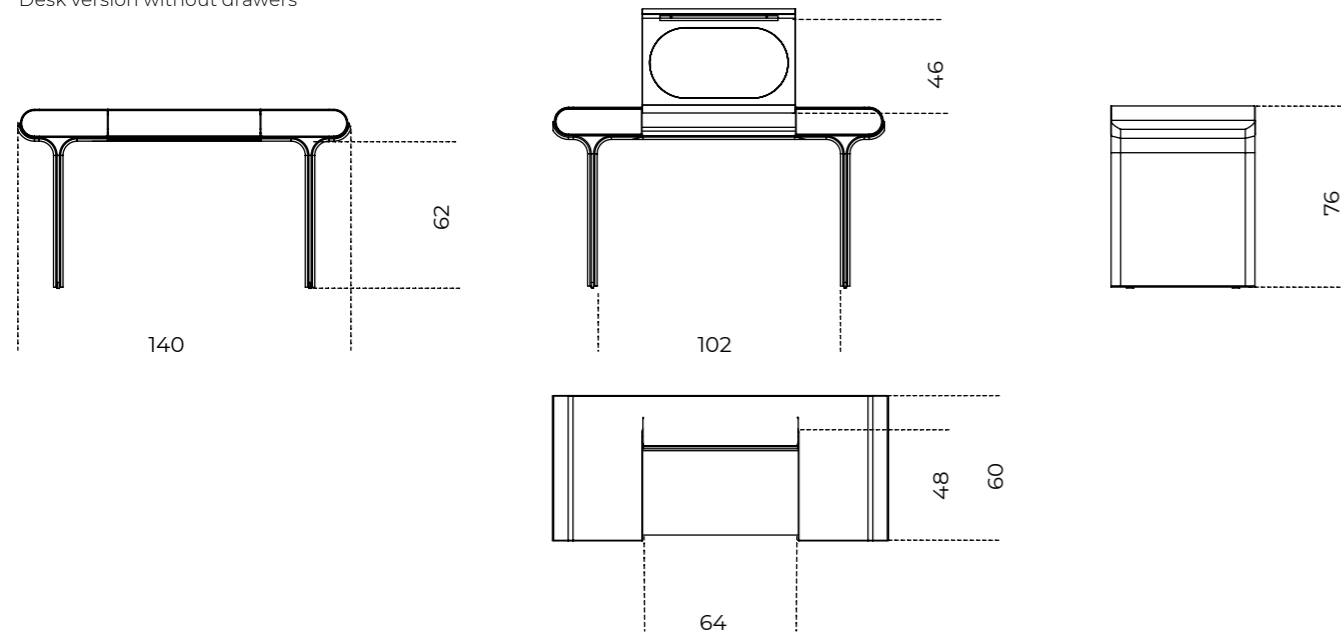

**Versione desk con cassetti**  
Desk version with drawers

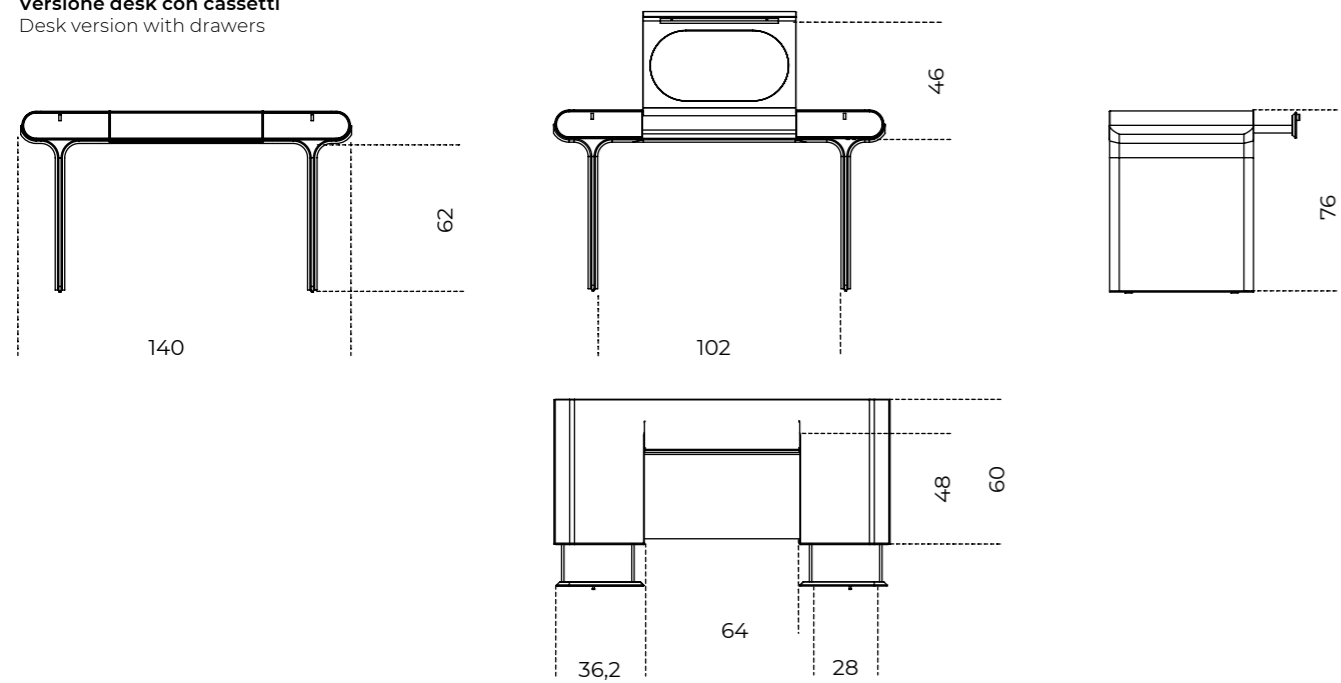

**Venere** | Carlo Colombo, 2013

Product information / p. 532

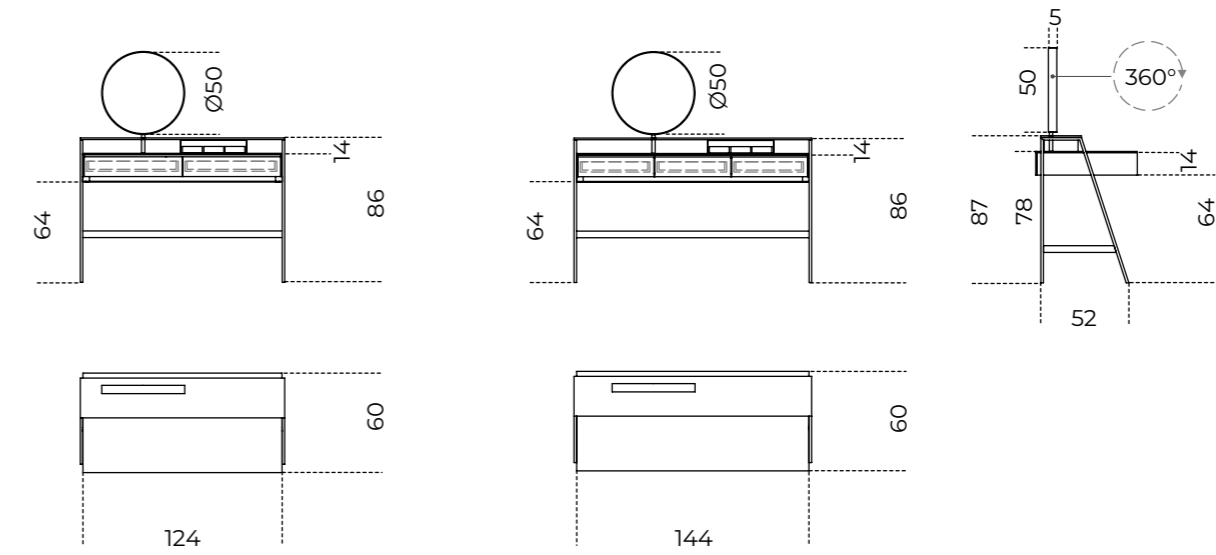

**Con specchio ingranditore**  
With magnifying mirror

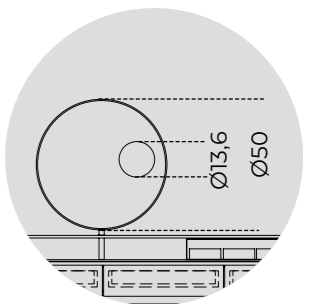
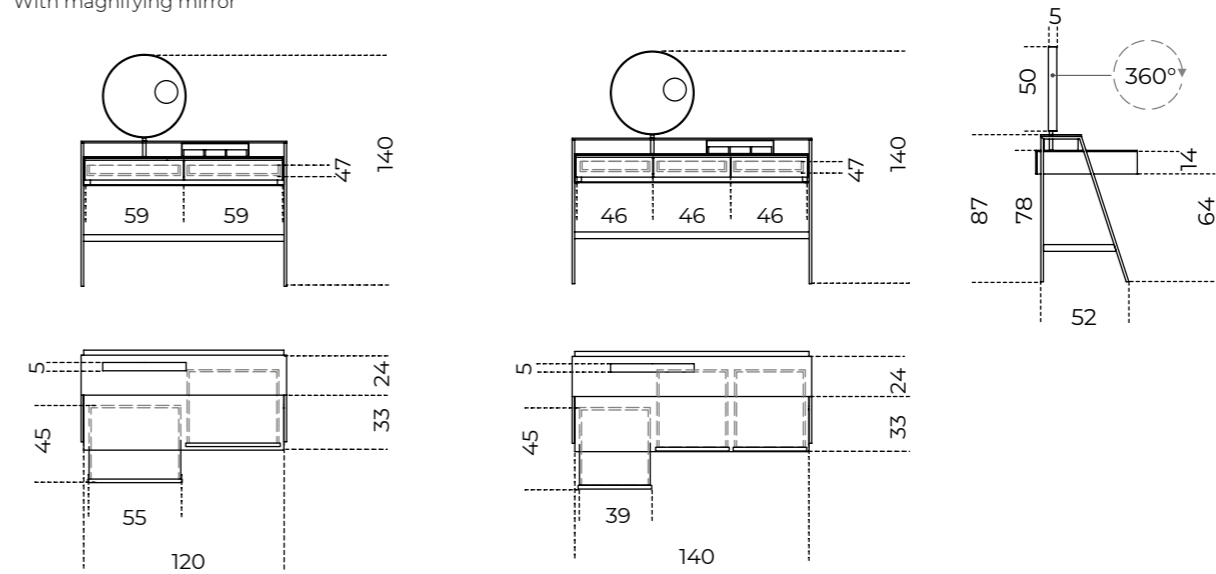

**Specchio ingranditore**  
Magnifying mirror

**13** Divisori /  
Dividers

542 **Chloé**  
544 **Shield**

546 **Informazioni tecniche/**  
Technical informations



# Chloé

Studio G&R / 2016

Paravento con struttura in legno e metallo laccato ottone satinato. Lati rivestiti in specchio extralight e tessuto "Ribon Opaline" di Lelièvre Signature. Basi in marmo lucido naturale Calacatta Vagli Oro. A richiesta con tessuto cliente.

## NOTE TECNICHE SUI MATERIALI

**MARMO** | Il marmo è un materiale naturale di origine sedimentaria che può presentare particolarità come venature, lievi irregolarità superficiali, colorazioni differenti e cristallizzazioni. Queste peculiarità sono da attribuirsi alla naturalezza del materiale e non sono da considerarsi difetti ma caratteristiche tipiche del marmo. Ogni prodotto risulterà unico, esclusivo e non replicabile.

Screen with satin brass lacquered wooden and metal structure. Sides covered by extralight mirror and fabric "Ribon Opaline" by Lelièvre Signature. Natural polished Calacatta Vagli Oro marble bases. Covered by customer's fabric on request.

## TECHNICAL INFORMATION ON THE MATERIALS

**MARBLE** | The marble is a natural material of sedimentary origin that can present particularities such as veins, slight surface irregularities, different colors and crystallizations. These peculiarities are to be attributed to the naturalness of the material and are not to be considered defects but typical characteristics of marble. Each product will be unique, exclusive and non-replicable.



**Cm**  
135 x 15 x 217

**Inches**  
53¼" x 6" x 85½"

[For technical drawing / p. 548](#)

[Pricelist 2023 / p. 191](#)  
[Homescapes, embracing beauty / p. 53](#)

## STRUTTURA/STRUCTURE



Laccato ottone satinato  
Satin brass lacquered

## LATI/SIDES

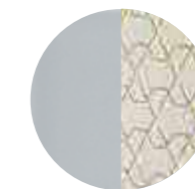

Specchio extralight /  
Tessuto "Ribon Opaline"  
Extralight mirror /  
Fabric "Ribon Opaline"

## BASE/BASE



Marmo lucido naturale  
Calacatta Vagli Oro  
Natural polished  
Calacatta Vagli Oro marble





▲ SHIELD  
Moduli in legno intarsiato Noce Colore Frisé e Tanganika bianco Frisé  
"Colore" Frisé Walnut inlay wood and Tanganika White Frisé modules

# Shield

Pietro Russo/2019

Paravento composto da 4 moduli in legno curvato intarsiato Noce Colore Frisé o Acero Frisé grigio scuro. Interno in Tanganika bianco Frisé. Struttura e accessori in ottone satinato con specchi 6mm extralight bisellati. Ciotola in ottone satinato con fondo rivestito in pelle scamosciata.

! Il legno è un materiale vivo che subisce un naturale processo di ossidazione che può causare cambiamenti cromatici. Venature e tonalità di colore differenti delle lastre non sono da considerarsi come difetti, ma caratteristiche che esaltano l'unicità del materiale.

#### NOTE TECNICHE SUI MATERIALI

**INTARSIO** | L'intarsio è una tecnica di lavorazione artigianale utilizzata per ottenere un particolare disegno e si realizza accostando elementi di materiali differenti (come legno e alluminio) oppure dello stesso materiale. Questa lavorazione rende il prodotto unico ed esclusivo. Le eventuali variazioni cromatiche e di venatura del legno sono da considerarsi caratteristiche del materiale stesso e non possono essere controllate.

Screen composed by 4 curved "Colore" Frisé walnut or Maple Frisé dark grey inlaid wooden modules. Inside in Tanganika white Frisé. Satin brass structure and accessories with 6mm extralight bevelled mirrors. Satin brass tray with suede bottom.

! Wood is a living material and the natural oxidation process can cause chromatic changes. Different grain and colour shades of the wooden slabs are not to be considered as defects, but characteristics that enhance the uniqueness of the material.

#### TECHNICAL INFORMATION ON THE MATERIALS

**INLAY** | Inlay is an artisanal technique used to obtain a particular design and is made by combining elements of different materials (such as wood and aluminium) or of the same material. This process makes the product unique and exclusive. Any colour and grain variations of the wood are to be considered as characteristics of the material itself and cannot be controlled.



For technical drawing / p. 548

**Cm**  
204 x 39 x 192

**Inches**  
80½" x 15½" x 75¾"

Pricelist 2023 / p.202  
Homescapes, sense of materials / p. 74, 78-79  
Homescapes, gentle attitude / pp. 58, 60, 61

#### MODULI/MODULES



Legno intarsiato  
Noce "Colore" Frisé/  
Tanganika bianco Frisé  
"Colore" Frisé Walnut  
inlay wood/  
Tanganika White Frisé

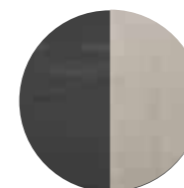

Acero Frisé/  
Tanganika bianco Frisé  
Maple Frisé dark grey/  
Tanganika White Frisé

#### STRUTTURA E ACCESSORI/ STRUCTURE AND ACCESSORIES



Ottone satinato  
Satin brass



Specchio extralight  
bisellato  
Extralight bevelled mirror

# 13

**Divisori / Dividers**  
**TECHNICAL MODULE**

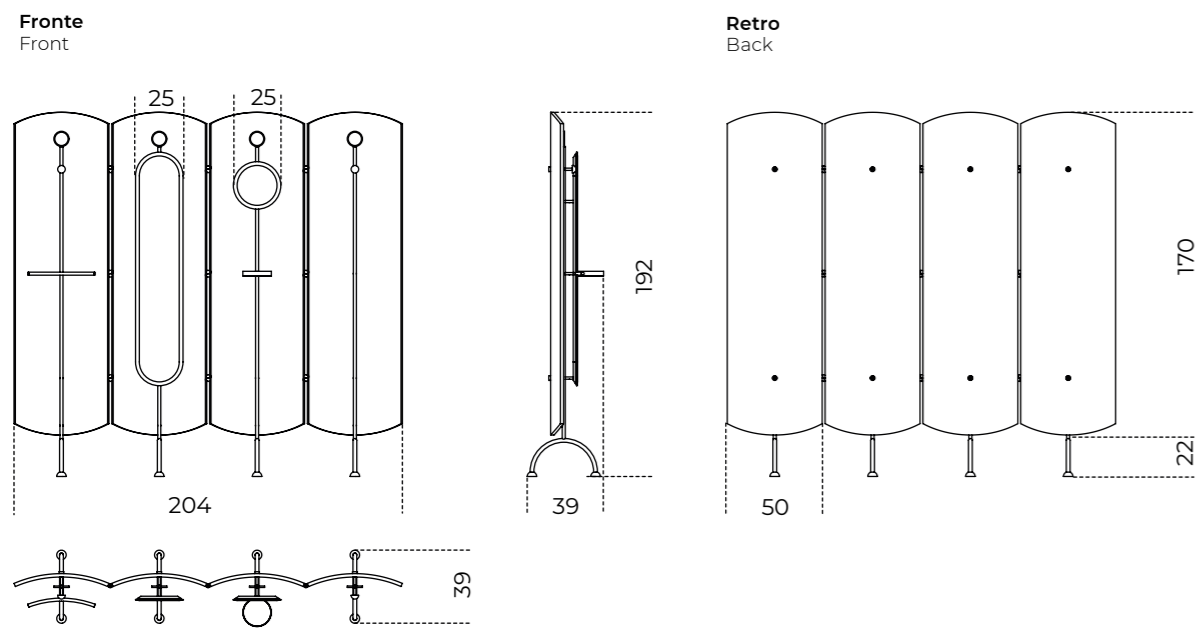
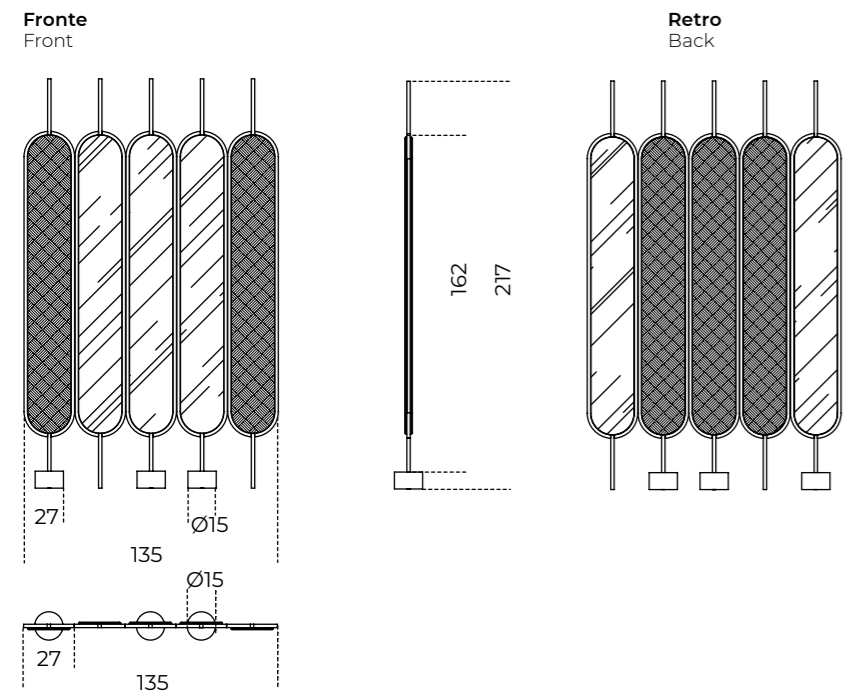

## **14** Lampade / Lightings

- [552](#) **Bolle 4**
- [554](#) **Bolle 6**
- [556](#) **Bolle Aria**
- [558](#) **Bolle Cielo**
- [560](#) **Bolle Orizzontale**
- [562](#) **Bolle Sola**
- [564](#) **Bolle Stelo**
- [566](#) **Bolle Tavolo 1**
- [568](#) **Bolle Tavolo 3**
- [570](#) **Bolle Tela**
- [572](#) **Bolle Terra**
- [574](#) **Bolle Verticale**
- [576](#) **Bonfire**
- [578](#) **Diantha**
- [580](#) **Diantha Terra**
- [582](#) **Epsilon**
- [584](#) **Epsilon Sola**
- [586](#) **Eris**
- [588](#) **Jolie**
- [590](#) **Jolie Applique**
- [592](#) **Key-to-Heaven**
- [594](#) **Key-to-Heaven Fix**
- [596](#) **Narghilè**
- [598](#) **Ori**
- [600](#) **Spectrum**
  
- [602](#) **Informazioni tecniche/  
Technical informations**



▲ BOLLE  
Bolle 4 e Bolle 6  
Bolle 4 and Bolle 6

# Bolle 4

Massimo Castagna / 2015

Lampada a sospensione a luce LED dimmerabile con 4 sfere in cristallo trasparente soffiato a bocca. Disponibile anche versione con sfere colorate in cristallo soffiato a bocca nei colori "topazio", "ambra", "ametista" e "bronzite". Parti metalliche in ottone brunito a mano. L'altezza può essere realizzata a misura, da un minimo di 73 cm ad un massimo di 600 cm (incluso corpo luminoso).

Le lampade BOLLE sono fornite complete di lampadine come servizio di cortesia.

**Composta da:**  
2 sfere Ø20 cm / Ø8"  
2 sfere Ø25 cm / Ø10"

## ! Braccetti non regolabili.

Versione 220-240V: la lampada viene fornita con driver per dimmerazione in taglio di fase.  
Versione 110V: la lampada viene fornita con driver per dimmerazione 1-10V.

In caso di presenza di un diverso sistema di dimmerazione o per connessione con sistema di domotica, si prega di specificare al momento dell'ordine per verificarne la compatibilità.

## NOTE TECNICHE SUI MATERIALI

**VETRO SOFFIATO A BOCCA** | Piccole variazioni dimensionali sono dovute alla lavorazione artigianale del vetro fuso.

**OTTONE BRUNITO A MANO** | L'ottone brunito a mano è ottenuto da un processo di ossidazione naturale eseguito manualmente. Il risultato di questa lavorazione è un prodotto che può presentare macchie e variazioni di colore che non sono da considerarsi imperfezioni ma caratteristiche che conferiscono ad ogni pezzo una particolare unicità, rendendolo esclusivo.

Hanging lamp with dimmable LED light with 4 transparent mouth-blown glass spheres. Also available version with coloured mouth-blown glass spheres available in "topazio", "ambra", "ametista" and "bronzite" colours. Metal parts in hand burnished brass. The height can be customised from a minimum of 73cm to a maximum of 600cm (including lights).

As courtesy BOLLE lamps are supplied with light bulbs.

**Composed by:**  
2 spheres Ø20 cm / Ø8"  
2 spheres Ø25 cm / Ø10"

## ! Non-adjustable arms.

Version 220-240V: the lamp is supplied with phase-cut driver.  
Version 110V: the lamp is supplied with 1-10V driver.

In case of need for different dimmer system or for the connection to home automation system, please inform us prior to ordering for checking compatibility.

## TECHNICAL INFORMATION ON THE MATERIALS

**MOUTH-BLOWN GLASS** | Small dimensional variations are due to the handcrafted processing of molten glass.

**HAND BURNISHED BRASS** | The hand burnished brass is the consequence of hand-made process of natural oxidation. The result of this processing is a product that may show marks and colour variations. These differences are inevitable and should not be considered imperfections but evidence of the hand-crafted process. They enhance the beauty and distinctiveness of a unique piece.



## INFORMAZIONI TECNICHE/ TECHNICAL INFORMATIONS

CTT: 2700K  
CRI: ≥ 80  
Light output: 800lm  
Light sources: G4 12V 1,8W each  
Dimmability: phase-cut (220-240V),  
1-10V (110V)  
Weight: ≈20kg



For technical drawing / p. 606

Pricelist 2023 / p. 166  
Homescapes, intimate portraits / p. 82  
Homescapes, gentle attitude / p. 103

Cm

70 x 68 x 128\*

\* H totale incluso sfere

Inches

27<sup>3/4</sup>" x 27" x 50<sup>1/2</sup>"\*

\*H total height including spheres

## SFERE/SPHERES



Cristallo trasparente  
soffiato a bocca  
Transparent mouth-blown  
glass



Cristallo trasparente  
"ametista"  
"Amethysta" mouth-blown  
glass



Cristallo trasparente  
"bronzite"  
"Bronzite" mouth-blown  
glass

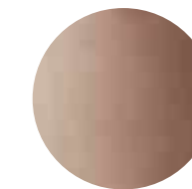

Cristallo trasparente  
"ametista"  
"Amethysta" mouth-blown  
glass

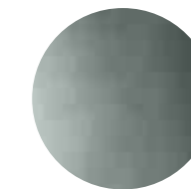

Cristallo trasparente  
"topazio"  
"Topazio" mouth-blown  
glass



Ottone brunito a mano  
Hand burnished brass

## PARTI METALLICHE/ METAL PARTS



▲ BOLLE  
Bolle 4 e Bolle 6  
Bolle 4 and Bolle 6

# Bolle 6

Massimo Castagna / 2015

Lampada a sospensione a luce LED dimmerabile con 6 sfere in cristallo trasparente soffiato a bocca.

Disponibile anche versione con sfere colorate in cristallo soffiato a bocca nei colori "topazio", "ambra", "ametista" e "bronzite". Parti metalliche in ottone brunito a mano. L'altezza può essere realizzata a misura da un minimo di 85 cm ad un massimo di 600 cm (incluso corpo luminoso).

Le lampade BOLLE sono fornite complete di lampadine come servizio di cortesia.

**Composta da:**  
3 sfere Ø20 cm / Ø8"  
3 sfere Ø25 cm / Ø10"

## ! Braccetti non regolabili.

Versione 220-240V: la lampada viene fornita con driver per dimmerazione in taglio di fase. Versione 110V: la lampada viene fornita con driver per dimmerazione 1-10V.

In caso di presenza di un diverso sistema di dimmerazione o per connessione con sistema di domotica, si prega di specificare al momento dell'ordine per verificarne la compatibilità.

## NOTE TECNICHE SUI MATERIALI

**VETRO SOFFIATO A BOCCA** | Piccole variazioni dimensionali sono dovute alla lavorazione artigianale del vetro fuso.

**OTTONE BRUNITO A MANO** | L'ottone brunito a mano è ottenuto da un processo di ossidazione naturale eseguito manualmente. Il risultato di questa lavorazione è un prodotto che può presentare macchie e variazioni di colore che non sono da considerarsi imperfezioni ma caratteristiche che conferiscono ad ogni pezzo una particolare unicità, rendendolo esclusivo.

Hanging lamp with dimmable LED light with 6 transparent mouth-blown glass spheres. Also available version with coloured mouth-blown glass spheres available in "topazio", "ambra", "ametista" and "bronzite" colours. Metal parts in hand burnished brass. The height can be customised from a minimum of 85cm to a maximum of 600cm (including lights).

As courtesy BOLLE lamps are supplied with light bulbs.

**Composed by:**  
3 spheres Ø20 cm / Ø8"  
3 spheres Ø25 cm / Ø10"

## ! Non-adjustable arms.

Version 220-240V: the lamp is supplied with phase-cut driver. Version 110V: the lamp is supplied with 1-10V driver.

In case of need for different dimmer system or for the connection to home automation system, please inform us prior to ordering for checking compatibility.

## TECHNICAL INFORMATION ON THE MATERIALS

**MOUTH\_BLOWN GLASS** | Small dimensional variations are due to the handcrafted processing of molten glass.

**HAND BURNISHED BRASS** | The hand burnished brass is the consequence of hand-made process of natural oxidation. The result of this processing is a product that may show marks and colour variations. These differences are inevitable and should not be considered imperfections but evidence of the hand-crafted process. They enhance the beauty and distinctiveness of a unique piece.



## INFORMAZIONI TECNICHE/ TECHNICAL INFORMATION

CTT: 2700K  
CRI: ≥ 80  
Light output: 1200lm Light sources:  
G4 12V 1,8W each Dimmability:  
phase-cut (220-240V), 1-10V (110V)  
Weight: ≈20kg



[For technical drawing / p. 606](#)

[Pricelist 2023 / p. 166](#)  
[Homescapes, intimate portraits / p. 82](#)  
[Homescapes, gentle attitude / p. 103](#)

## Cm

90 x 80 x 128\*

\* H totale incluso sfere

## Inches

35½" x 31½" x 50½"

\*H total height including spheres

## SFERE/SPHERES



Cristallo trasparente  
soffiato a bocca  
Transparent mouth-blown  
glass



Cristallo trasparente  
"ametista"  
"Ametista" mouth-blown  
glass



Cristallo trasparente  
"bronzite"  
"Bronzite" mouth-blown  
glass



Cristallo trasparente  
"ametista"  
"Ametista" mouth-blown  
glass

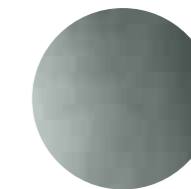

Cristallo trasparente  
"topazio"  
"Topazio" mouth-blown  
glass



Ottone brunito a mano  
Hand burnished brass

## PARTI METALLICHE/ METAL PARTS



# Bolle Aria

Massimo Castagna / 2020

Lampada da parete o soffitto a luce LED dimmerabile con 3 sfere in cristallo trasparente soffiato a bocca. Disponibile anche versione con sfere colorate in cristallo soffiato a bocca nei colori "topazio", "ambra", "ametista" e "bronzite". Parti metalliche in ottone brunito a mano.

Le lampade BOLLE ARIA sono fornite complete di lampadine come servizio di cortesia.

**Composta da:**  
2 sfere Ø25 cm / Ø10"  
1 sfera Ø30 cm / Ø12"

! Per versione 110V rosone differente, vedi disegni pp.50.

Braccetti non regolabili.

Versione 220-240V: la lampada viene fornita con driver per dimmerazione in taglio di fase. Versione 110V: la lampada viene fornita con driver per dimmerazione 1-10V.

In caso di presenza di un diverso sistema di dimmerazione o per connessione con sistema di domotica, si prega di specificare al momento dell'ordine per verificarne la compatibilità.

## NOTE TECNICHE SUI MATERIALI

**VETRO SOFFIATO A BOCCA** | Piccole variazioni dimensionali sono dovute alla lavorazione artigianale del vetro fuso.

**OTTONE BRUNITO A MANO** | L'ottone brunito a mano è ottenuto da un processo di ossidazione naturale eseguito manualmente. Il risultato di questa lavorazione è un prodotto che può presentare macchie e variazioni di colore che non sono da considerarsi imperfezioni ma caratteristiche che conferiscono ad ogni pezzo una particolare unicità, rendendolo esclusivo.

Wall or ceiling fitted lamp with dimmable LED light with 3 transparent mouth-blown glass spheres. Also available version with coloured mouth-blown glass spheres available in "topazio", "ambra", "ametista" and "bronzite" colours. Metal parts in hand burnished brass.

As courtesy BOLLE ARIA lamps are supplied with light bulbs.

**Composed by:**  
2 spheres Ø25 cm / Ø10"  
1 sphere Ø30 cm / Ø12"

! Different canopy for 110V version, see drawings pp.50.

Non-adjustable arms.

Version 220-240V: the lamp is supplied with phase-cut driver. Version 110V: the lamp is supplied with 1-10V driver.

In case of need for different dimmer system or for the connection to home automation system, please inform us prior to ordering for checking compatibility.

## TECHNICAL INFORMATION ON THE MATERIALS

**MOUTH\_BLOWN GLASS** | Small dimensional variations are due to the handcrafted processing of molten glass.

**HAND BURNISHED BRASS** | The hand burnished brass is the consequence of hand-made process of natural oxidation. The result of this processing is a product that may show marks and colour variations. These differences are inevitable and should not be considered imperfections but evidence of the hand-crafted process. They enhance the beauty and distinctiveness of a unique piece.



## INFORMAZIONI TECNICHE/ TECHNICAL INFORMATIONS

CTT: 2700K  
CRI: ≥ 80  
Light output: 600lm  
Light sources: G4 12V 1,8W each  
Dimmability: phase-cut (220-240V),  
1-10V (110V)  
Weight: ≈8kg



For technical drawing / p. 606

Pricelist 2023 / p. 167  
Homescapes, embracing beauty / pp. 55, 82  
Homescapes, intimate portraits / p. 18  
Homescapes, gentle attitude / pp. 37, 39

**Cm**  
58 x 54,5 x 60

**Inches**  
23" x 21½" x 23¾"

## SFERE/SPHERES



**Cristallo trasparente soffiato a bocca**  
Transparent mouth-blown glass



**Cristallo trasparente "ametista"**  
"Amethyst" mouth-blown glass



**Cristallo trasparente "bronzite"**  
"Bronzite" mouth-blown glass

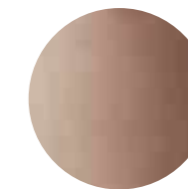

**Cristallo trasparente "ametista"**  
"Amethyst" mouth-blown glass

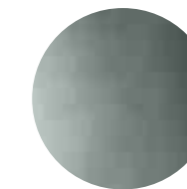

**Cristallo trasparente "topazio"**  
"Topaz" mouth-blown glass



**Ottone brunito a mano**  
Hand burnished brass

# Bolle Cielo

Massimo Castagna / 2020

Lampada a sospensione a luce LED dimmerabile disponibile con 6 o 9 sfere in cristallo trasparente soffiato a bocca. Disponibile anche versione con sfere colorate in cristallo soffiato a bocca nei colori "topazio", "ambra", "ametista" e "bronzite". Parti metalliche in ottone brunito a mano. Con cavo elettrico e cavo di acciaio da 4 mt. per regolare l'altezza.

Hanging lamp with dimmable LED light with 6 or 9 transparent mouth-blown glass spheres. Also available version with coloured mouth-blown glass spheres available in "topazio", "ambra", "ametista" and "bronzite" colours. Metal parts in hand burnished brass. Supplied with 4 meters long electric and steel cables to customize height.

Le lampade BOLLE CIELO sono fornite complete di lampadine come servizio di cortesia.

As courtesy BOLLE CIELO lamps are supplied with light bulbs.

**Versione 6 sfere composta da:**  
6 sfere Ø30 cm / Ø12"

**Versione 9 sfere composta da:**  
9 sfere Ø30 cm / Ø12"

**6 spheres version composed by:**  
6 spheres Ø30 cm / Ø12"

**9 spheres version composed by:**  
9 spheres Ø30 cm / Ø12"

! **Versione 220-240V:** la lampada viene fornita con driver per dimmerazione in taglio di fase.  
! **Versione 110V:** la lampada viene fornita con driver per dimmerazione 1-10V.

! **Version 220-240V:** the lamp is supplied with phase-cut driver.  
! **Version 110V:** the lamp is supplied with 1-10V driver.

In caso di presenza di un diverso sistema di dimmerazione o per connessione con sistema di domotica, si prega di specificare al momento dell'ordine per verificarne la compatibilità.

In case of need for different dimmer system or for the connection to home automation system, please inform us prior to ordering for checking compatibility.

## NOTE TECNICHE SUI MATERIALI

**VETRO SOFFIATO A BOCCA** | Piccole variazioni dimensionali sono dovute alla lavorazione artigianale del vetro fuso.

## TECHNICAL INFORMATION ON THE MATERIALS

**MOUTH\_BLOWN GLASS** | Small dimensional variations are due to the handcrafted processing of molten glass.

**OTTONE BRUNITO A MANO** | L'ottone brunito a mano è ottenuto da un processo di ossidazione naturale eseguito manualmente. Il risultato di questa lavorazione è un prodotto che può presentare macchie e variazioni di colore che non sono da considerarsi imperfezioni ma caratteristiche che conferiscono ad ogni pezzo una particolare unicità, rendendolo esclusivo.

**HAND BURNISHED BRASS** | The hand burnished brass is the consequence of hand-made process of natural oxidation. The result of this processing is a product that may show marks and colour variations. These differences are inevitable and should not be considered imperfections but evidence of the hand-crafted process. They enhance the beauty and distinctiveness of a unique piece.



## INFORMAZIONI TECNICHE/ TECHNICAL INFORMATIONS

**CTT:** 2700K  
**CRI:** ≥ 80  
**Light output:** 1200lm (Bolle Cielo 6), 1800lm (Bolle Cielo 9)  
**Light sources:** G4 12V 1,8W each  
**Dimmability:** phase-cut (220-240V), 1-10V (110V)  
**Cable length:** 4mt  
**Weight:** ≈20kg (Bolle Cielo 6), ≈30kg (Bolle Cielo 9)



For technical drawing / p. 607

Pricelist 2023 / p.168  
HomesCAPes, embracing beauty / pp. 36, 75  
HomesCAPes, gentle attitude / pp. 15, 17

## Cm

**Versione 6 sfere**  
82,5 x 84 x 74\*  
**Versione 9 sfere**  
82,5 x 84 x 74\*

\* Altezza totale escluso cavo e rosone

## Inches

**Version 6 spheres**  
32½" x 33¼" x 29¼"\*  
**Version 9 spheres**  
32½" x 33¼" x 29¼"\*

\* Overall height excluding cables and ceiling plate

## SFERE/SPHERES



**Cristallo trasparente soffiato a bocca**  
Transparent mouth-blown glass



**Cristallo trasparente "ametista"**  
"Ametista" mouth-blown glass

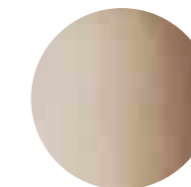

**Cristallo trasparente "bronzite"**  
"Bronzite" mouth-blown glass

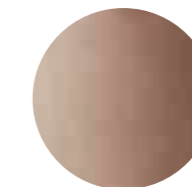

**Cristallo trasparente "ametista"**  
"Ametista" mouth-blown glass

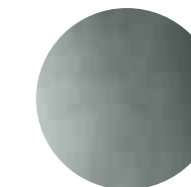

**Cristallo trasparente "topazio"**  
"Topazio" mouth-blown glass



**Ottone brunito a mano**  
Hand burnished brass



# Bolle Orizzontale

Massimo Castagna / 2019

Lampada a sospensione a luce LED dimmerabile disponibile con 10 sfere oppure 16 sfere in cristallo trasparente soffiato a bocca. Disponibile anche versione con sfere colorate in cristallo soffiato a bocca nei colori "topazio", "ambra", "ametista" e "bronzite". Parti metalliche in ottone brunito a mano. In dotazione cavo di 4mt per regolare l'altezza.

Hanging lamp with dimmable LED light. Available 10 or 16 transparent mouth-blown glass spheres. Also available version with coloured mouth-blown glass spheres available in "topazio", "ambra", "ametista" and "bronzite" colours. Metal parts in hand burnished brass. Supplied with cable 4mt long to customize height.

Le lampade BOLLE ORIZZONTALE sono fornite complete di lampadine come servizio di cortesia.

As courtesy BOLLE ORIZZONTALE lamps are supplied with light bulbs.

## Versione 10 sfere composta da:

2 sfere Ø20 cm / Ø8"  
4 sfere Ø25 cm / Ø10"  
4 sfere Ø30 cm / Ø12"

## Versione 16 sfere composta da:

2 sfere Ø20 cm / Ø8"  
6 sfere Ø25 cm / Ø10"  
8 sfere Ø30 cm / Ø12"

## 10 spheres version composed by:

2 spheres Ø20 cm / Ø8"  
4 spheres Ø25 cm / Ø10"  
4 spheres Ø30 cm / Ø12"

## 16 spheres version composed by:

2 spheres Ø20 cm / Ø8"  
6 spheres Ø25 cm / Ø10"  
8 spheres Ø30 cm / Ø12"

## ! Braccetti non regolabili.

La lampada viene fornita con driver per dimmerazione 1-10V.

In caso di presenza di un diverso sistema di dimmerazione o per connessione con sistema di domotica, si prega di specificare al momento dell'ordine per verificarne la compatibilità.

## ! Non-adjustable arms.

The lamp is supplied with 1-10V driver.

In case of need for different dimmer system or for the connection to home automation system, please inform us prior to ordering for checking compatibility.

## NOTE TECNICHE SUI MATERIALI

**VETRO SOFFIATO A BOCCA** | Piccole variazioni dimensionali sono dovute alla lavorazione artigianale del vetro fuso.

**OTTONE BRUNITO A MANO** | L'ottone brunito a mano è ottenuto da un processo di ossidazione naturale eseguito manualmente. Il risultato di questa lavorazione è un prodotto che può presentare macchie e variazioni di colore che non sono da considerarsi imperfezioni ma caratteristiche che conferiscono ad ogni pezzo una particolare unicità, rendendolo esclusivo.

## TECHNICAL INFORMATION ON THE MATERIALS

**MOUTH\_BLOWN GLASS** | Small dimensional variations are due to the handcrafted processing of molten glass.

**HAND BURNISHED BRASS** | The hand burnished brass is the consequence of hand-made process of natural oxidation. The result of this processing is a product that may show marks and colour variations. These differences are inevitable and should not be considered imperfections but evidence of the hand-crafted process. They enhance the beauty and distinctiveness of a unique piece.



## INFORMAZIONI TECNICHE/ TECHNICAL INFORMATIONS

CTT: 2700K  
CRI: ≥ 80  
Light output: 2000lm (Bolle Orizzontale 10),  
3200lm (Bolle Orizzontale 16)  
Light sources: G4 12V 1,8W each  
Dimmability: 1-10V  
Cable length: 4mt  
Weight: ≈ 41kg (Bolle Orizzontale 10),  
≈ 61kg (Bolle Orizzontale 16)



For technical drawing / p. 607

Pricelist 2023 / p. 169  
Homescapes, sense of materials / p. 44  
Homescapes, embracing beauty / p. 16  
Homescapes, gentle attitude / pp. 81, 83

## Cm

Versione 10 sfere  
200 x 120 x 85  
Versione 16 sfere  
300 x 120 x 85

## Inches

Version 10 spheres  
78¾" x 47¼" x 33½"  
Version 16 spheres  
118¾" 47¼" x 33½"

## SFERE/SPHERES



Cristallo trasparente  
soffiato a bocca  
Transparent mouth-blown  
glass

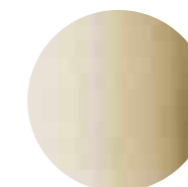

Cristallo trasparente  
"ametista"  
"Ametista" mouth-blown  
glass

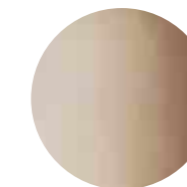

Cristallo trasparente  
"bronzite"  
"Bronzite" mouth-blown  
glass



Cristallo trasparente  
"ametista"  
"Ametista" mouth-blown  
glass

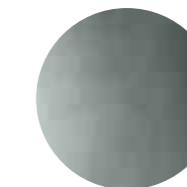

Cristallo trasparente  
"topazio"  
"Topazio" mouth-blown  
glass



Ottone brunito a mano  
Hand burnished brass



▲ **BOLLE SOLA**  
 n.2 Bolle Sola Ø25 e n.2 Bolle Sola Ø20  
 n.2 Bolle Sola Ø25 and n.2 Bolle Sola Ø20

# Bolle Sola

Massimo Castagna / 2015

Lampada a sospensione a luce LED non dimmerabile. Sfera in cristallo trasparente soffiato a bocca. Disponibile anche versione con sfere colorate in cristallo soffiato a bocca nei colori "topazio", "ambra", "ametista" e "bronzite". Parti metalliche in ottone brunito a mano. In dotazione cavo da 4mt per regolare l'altezza. Su richiesta realizzabili set da 3 e 5 lampade con un unico rosone, questa versione è dimmerabile solo per voltaggio 220-240V.

Hanging lamp with LED light (not dimmable). Transparent mouth-blown glass sphere. Also available version with coloured mouth-blown glass spheres available in "topazio", "ambra", "ametista" and "bronzite" colours. Metal parts in hand burnished brass. Supplied with cable 4mt long to customize height. On request set of 3 or 5 lamps with unique canopy, this version is dimmable only for 220-240V voltage.

Le lampade BOLLE SOLA sono fornite complete di lampadine come servizio di cortesia.

As courtesy BOLLE SOLA lamps are supplied with light bulbs.

**Rosone unico  
set 3 pezzi:**

2 sfere Ø20 cm / Ø8"  
1 sfera Ø25 cm / Ø10"

**Rosone unico  
set 5 pezzi:**

3 sfere Ø20 cm / Ø8"  
2 sfere Ø25 cm / Ø10"

**Unique canopy  
set of 3 pcs:**

2 spheres Ø20 cm / Ø8"  
1 sphere Ø25 cm / Ø10"

**Unique canopy  
set of 5 pcs:**

3 spheres Ø20 cm / Ø8"  
2 spheres Ø25 cm / Ø10"

! Per versione 110V rosone differente, vedi disegni pp.50

! Different canopy for 110V version, see drawings pp.50.

La composizione da 3 e 5 lampade con un unico rosone è dimmerabile solo per voltaggio 220-240V. Questa versione viene fornita con driver per dimmerazione in taglio di fase.

The composition of 3 or 5 lamps with unique canopy is dimmable only for 220-240V voltage. This version is supplied with phase-cut driver.

In caso di presenza di un diverso sistema di dimmerazione o per connessione con sistema di domotica, si prega di specificare al momento dell'ordine per verificarne la compatibilità.

In case of need for different dimmer system or for the connection to home

#### NOTE TECNICHE SUI MATERIALI

**VETRO SOFFIATO A BOCCA** | Piccole variazioni dimensionali sono dovute alla lavorazione artigianale del vetro fuso.

#### TECHNICAL INFORMATION ON THE MATERIALS

**MOUTH-BLOWN GLASS** | Small dimensional variations are due to the handcrafted processing of molten glass.

**OTTONE BRUNITO A MANO** | L'ottone brunito a mano è ottenuto da un processo di ossidazione naturale eseguito manualmente. Il risultato di questa lavorazione è un prodotto che può presentare macchie e variazioni di colore che non sono da considerarsi imperfezioni ma caratteristiche che conferiscono ad ogni pezzo una particolare unicità, rendendolo esclusivo.

**HAND BURNISHED BRASS** | The hand burnished brass is the consequence of hand-made process of natural oxidation. The result of this processing is a product that may show marks and colour variations. These differences are inevitable and should not be considered imperfections but evidence of the hand-crafted process. They enhance the beauty and distinctiveness of a unique piece.



#### INFORMAZIONI TECNICHE/ TECHNICAL INFORMATIONS

CTT: 2700K  
 CRI: ≥ 80  
 Light output: 200lm  
 Light sources: G4 12V 1,8W each  
 Dimmability: NO - Dimmable  
 phase-cut just for 3-5 lamps version  
 (only for 220-240V)  
 Cable length: 4mt  
 Weight: ≈5kg



For technical drawing / p. 607

Pricelist 2023 / p. 170  
 Homescapes, sense of materials / pp. 73, 110  
 Homescapes, intimate portraits / p. 40

**Cm**  
 Ø20 x 50,5  
 Ø25 x 62

**Inches**  
 Ø8" x 20"  
 Ø10" x 24½"

#### SFERE/SPHERES



**Cristallo trasparente soffiato a bocca**  
 Transparent mouth-blown glass



**Cristallo trasparente "ametista"**  
 "Ametista" mouth-blown glass

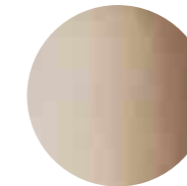

**Cristallo trasparente "bronzite"**  
 "Bronzite" mouth-blown glass

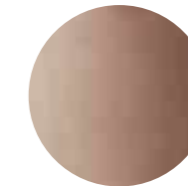

**Cristallo trasparente "ametista"**  
 "Ametista" mouth-blown glass

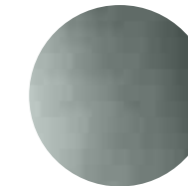

**Cristallo trasparente "topazio"**  
 "Topazio" mouth-blown glass



**Ottone brunito a mano**  
 Hand burnished brass

#### PARTI METALLICHE/ METAL PARTS

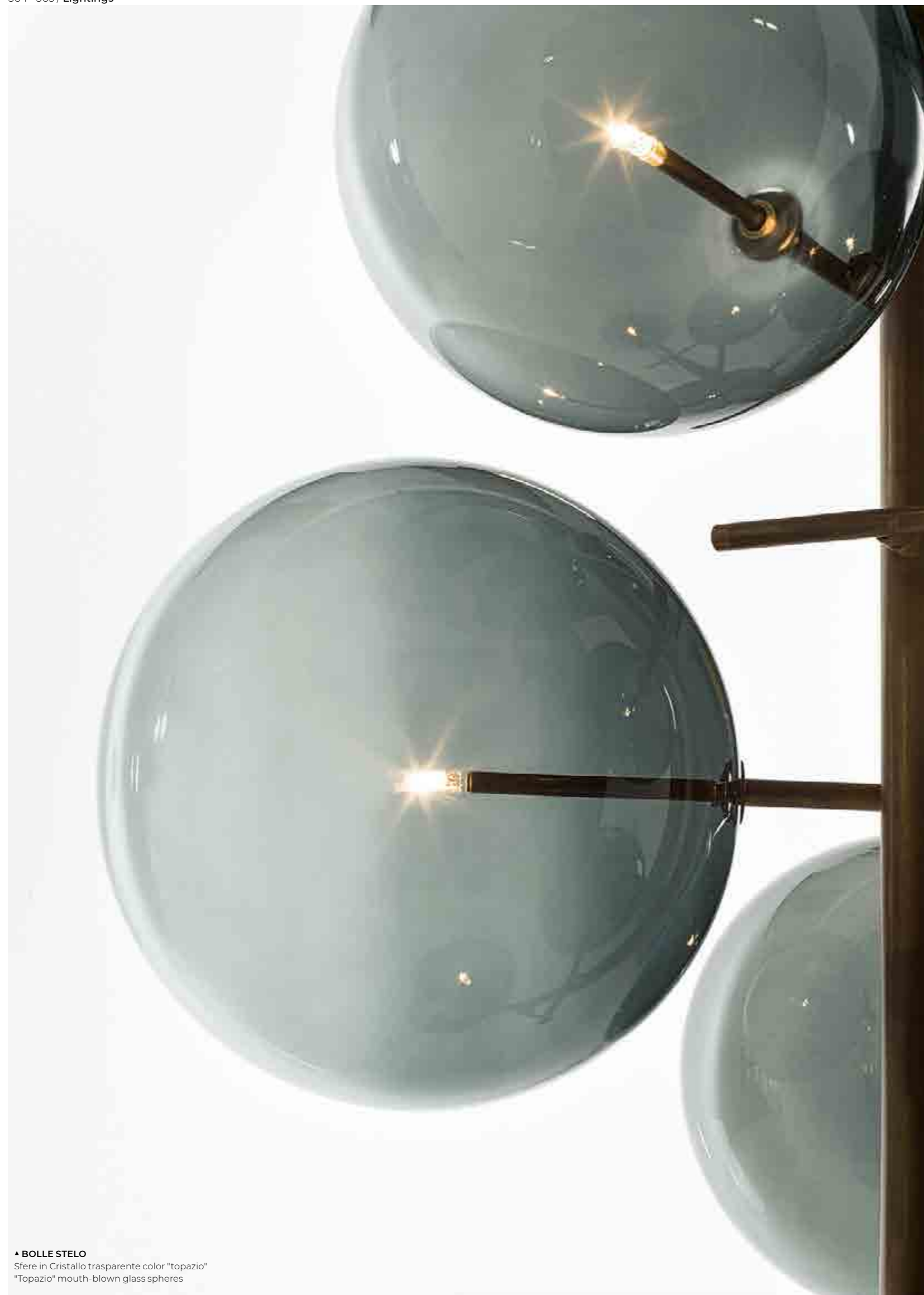

▲ **BOLLE STELO**  
Sfere in Cristallo trasparente color "topazio"  
"Topazio" mouth-blown glass spheres

# Bolle Stelo

Massimo Castagna / 2024

Lampada da terra a luce LED dimmerabile dotata di 7 sfere in cristallo trasparente soffiato a bocca. Disponibile anche versione con sfere colorate in cristallo soffiato a bocca nei colori "topazio", "ambra", "ametista" e "bronzite". Parti metalliche in ottone brunito a mano. Dimmer presente sul cavo di alimentazione. Basamento in ottone brunito a mano e metallo laccato nero.

Floor lamp with dimmable LED light with 7 transparent mouth-blown glass spheres. Also available version with coloured mouth-blown glass spheres available in "topazio", "ambra", "ametista" and "bronzite" colours. Hand burnished brass metal parts. Dimmer on the power cable. Base in hand burnished brass and black lacquered metal.

Le lampade BOLLE TAVOLO 1 sono fornite complete di lampadine come servizio di cortesia.

As courtesy BOLLE TAVOLO 1 lamps are supplied with light bulbs.

#### Composta da:

1 sfera Ø20 cm / Ø8"  
4 sfere Ø25 cm / Ø10"  
2 sfere Ø30 cm / Ø12"

#### Composed by:

1 sphere Ø20 cm / Ø8"  
4 spheres Ø25 cm / Ø10"  
2 spheres Ø30 cm / Ø12"

#### NOTE TECNICHE SUI MATERIALI

**VETRO SOFFIATO A BOCCA** | Piccole variazioni dimensionali sono dovute alla lavorazione artigianale del vetro fuso.

#### TECHNICAL INFORMATION ON THE MATERIALS

**MOUTH\_BLOWN GLASS** | Small dimensional variations are due to the handcrafted processing of molten glass.

**OTTONE BRUNITO A MANO** | L'ottone brunito a mano è ottenuto da un processo di ossidazione naturale eseguito manualmente. Il risultato di questa lavorazione è un prodotto che può presentare macchie e variazioni di colore che non sono da considerarsi imperfezioni ma caratteristiche che conferiscono ad ogni pezzo una particolare unicità, rendendolo esclusivo.

**HAND BURNISHED BRASS** | The hand burnished brass is the consequence of hand-made process of natural oxidation. The result of this processing is a product that may show marks and colour variations. These differences are inevitable and should not be considered imperfections but evidence of the hand-crafted process. They enhance the beauty and distinctiveness of a unique piece.



#### INFORMAZIONI TECNICHE/ TECHNICAL INFORMATIONS

CTT: 2700K  
CRI: ≥ 80  
Light output: 800lm  
Light sources: G4 12V 1W each  
Dimmability: push button dimmer  
on the power cable  
Cable length: 1,5mt



[For technical drawing / p. 608](#)

[Pricelist 2023 / p. 171](#)  
[Homescapes, intimate portraits / p. 88](#)

**Cm**  
Ø26 x 26 x 28

**Inches**  
Ø10¼" x 10¼" x 11¼"

#### SFERE/SPHERES



Cristallo trasparente soffiato a bocca  
Transparent mouth-blown glass



Cristallo trasparente "ametista"  
"Ametista" mouth-blown glass



Cristallo trasparente "bronzite"  
"Bronzite" mouth-blown glass

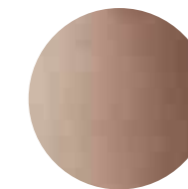

Cristallo trasparente "ametista"  
"Ametista" mouth-blown glass

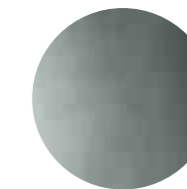

Cristallo trasparente "topazio"  
"Topazio" mouth-blown glass



Ottone brunito a mano  
Hand burnished brass



# Bolle Tavolo 1

Massimo Castagna / 2015

Lampada da tavolo singola a luce LED non dimmerabile. Sfera in cristallo trasparente soffiato a bocca. Disponibile anche versione con sfere colorate in cristallo soffiato a bocca nei colori "topazio", "ambra", "ametista" e "bronzite". Parti metalliche in ottone brunito a mano.

Le lampade BOLLE TAVOLO 1 sono fornite complete di lampadine come servizio di cortesia.

**Composta da:**  
1 sfera Ø25 cm/ Ø10"

#### NOTE TECNICHE SUI MATERIALI

**VETRO SOFFIATO A BOCCA** | Piccole variazioni dimensionali sono dovute alla lavorazione artigianale del vetro fuso.

**OTTONE BRUNITO A MANO** | L'ottone brunito a mano è ottenuto da un processo di ossidazione naturale eseguito manualmente. Il risultato di questa lavorazione è un prodotto che può presentare macchie e variazioni di colore che non sono da considerarsi imperfezioni ma caratteristiche che conferiscono ad ogni pezzo una particolare unicità, rendendolo esclusivo.

Single table lamp with LED light (not dimmable). Transparent mouth-blown glass sphere. Also available version with coloured mouth-blown glass spheres available in "topazio", "ambra", "ametista" and "bronzite" colours. Metal parts in hand burnished brass.

As courtesy BOLLE TAVOLO 1 lamps are supplied with light bulbs.

**Composed by:**  
1 sphere Ø25 cm/ Ø10"

#### TECHNICAL INFORMATION ON THE MATERIALS

**MOUTH-BLOWN GLASS** | Small dimensional variations are due to the handcrafted processing of molten glass.

**HAND BURNISHED BRASS** | The hand burnished brass is the consequence of hand-made process of natural oxidation. The result of this processing is a product that may show marks and colour variations. These differences are inevitable and should not be considered imperfections but evidence of the hand-crafted process. They enhance the beauty and distinctiveness of a unique piece.



#### INFORMAZIONI TECNICHE/ TECHNICAL INFORMATION

CTT: 2700K  
CRI: ≥ 80  
Light output: 200lm  
Light sources: G4 12V 1,8W each  
Dimmability: NO  
Cable length: 1,5mt



For technical drawing / p. 608

Pricelist 2023 / p. 171  
Homescapes, intimate portraits / p. 88

**Cm**  
Ø26 x 26 x 28

**Inches**  
Ø10¼" x 10¼" x 11¼"

#### SFERE/SPHERES



**Cristallo trasparente soffiato a bocca**  
Transparent mouth-blown glass



**Cristallo trasparente "ametista"**  
"Ametista" mouth-blown glass



**Cristallo trasparente "bronzite"**  
"Bronzite" mouth-blown glass

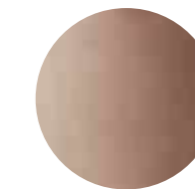

**Cristallo trasparente "ametista"**  
"Ametista" mouth-blown glass

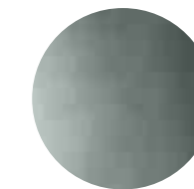

**Cristallo trasparente "topazio"**  
"Topazio" mouth-blown glass



**Ottone brunito a mano**  
Hand burnished brass

# Bolle Tavolo 3

Massimo Castagna / 2015

Lampada da tavolo a luce LED dimmerabile con 3 sfere in cristallo trasparente soffiato a bocca. Disponibile anche versione con sfere colorate in cristallo soffiato a bocca nei colori "topazio", "ambra", "ametista" e "bronzite". Parti metalliche in ottone brunito a mano. Dimmer presente sul cavo di alimentazione.

Table lamp with dimmable LED light with 3 transparent mouth-blown glass spheres. Also available version with coloured mouth-blown glass spheres available in "topazio", "ambra", "ametista" and "bronzite" colours. Metal parts in hand burnished brass. Dimmer on the power cable.

Le lampade BOLLE TAVOLO 3 sono fornite complete di lampadine come servizio di cortesia.

As courtesy BOLLE TAVOLO 3 lamps are supplied with light bulbs.

#### Composta da:

1 sfera Ø20 cm / Ø8"  
2 sfere Ø25 cm / Ø10"

#### Composed by:

1 sphere Ø20 cm / Ø8"  
2 spheres Ø25 cm / Ø10"

#### NOTE TECNICHE SUI MATERIALI

**VETRO SOFFIATO A BOCCA** | Piccole variazioni dimensionali sono dovute alla lavorazione artigianale del vetro fuso.

**OTTONE BRUNITO A MANO** | L'ottone brunito a mano è ottenuto da un processo di ossidazione naturale eseguito manualmente. Il risultato di questa lavorazione è un prodotto che può presentare macchie e variazioni di colore che non sono da considerarsi imperfezioni ma caratteristiche che conferiscono ad ogni pezzo una particolare unicità, rendendolo esclusivo.

#### TECHNICAL INFORMATION ON THE MATERIALS

**MOUTH\_BLOWN GLASS** | Small dimensional variations are due to the handcrafted processing of molten glass.

**HAND BURNISHED BRASS** | The hand burnished brass is the consequence of hand-made process of natural oxidation. The result of this processing is a product that may show marks and colour variations. These differences are inevitable and should not be considered imperfections but evidence of the hand-crafted process. They enhance the beauty and distinctiveness of a unique piece.



#### INFORMAZIONI TECNICHE/ TECHNICAL INFORMATIONS

CTT: 2700K  
CRI: ≥ 80  
Light output: 600lm  
Light sources: G4 12V 1,8W each  
Dimmability: push button dimmer on the power cable  
Cable lenght: 1,5mt



[For technical drawing / p. 608](#)

Pricelist 2023 / p. 172  
Homescapes, sense of materials / pp. 32, 89  
Homescapes, embracing beauty / p. 78

Cm  
58 x 52 x 44

Inches  
23" x 20½" x 17½"

#### SFERE/SPHERES



Cristallo trasparente soffiato a bocca  
Transparent mouth-blown glass



Cristallo trasparente "ametista"  
"Amethyst" mouth-blown glass



Cristallo trasparente "bronzite"  
"Bronzite" mouth-blown glass



Cristallo trasparente "ametista"  
"Amethyst" mouth-blown glass

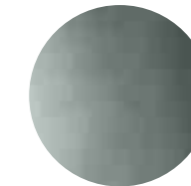

Cristallo trasparente "topazio"  
"Topazio" mouth-blown glass



Ottone brunito a mano  
Hand burnished brass



# Bolle Tela

Massimo Castagna / 2018

Lampada a sospensione a luce LED dimmerabile con 6 o 8 sfere in cristallo trasparente soffiato a bocca. Disponibile anche versione con sfere colorate in cristallo soffiato a bocca nei colori "topazio", "ambra", "ametista" e "bronzite". Parti metalliche in ottone brunito a mano. In dotazione cavo di 4mt per regolare l'altezza.

Hanging lamp with dimmable LED light with 6 or 8 transparent mouth-blown glass spheres. Also available version with coloured mouth-blown glass spheres available in "topazio", "ambra", "ametista" and "bronzite" colours. Metal parts in hand burnished brass. Supplied with cable 4mt long to customize height.

Le lampade BOLLE TELA sono fornite complete di lampadine come servizio di cortesia.

As courtesy BOLLE TELA lamps are supplied with light bulbs.

## Versione 6 sfere composta da:

2 sfere Ø20 cm / Ø8"  
2 sfere Ø25 cm / Ø10"  
2 sfere Ø30 cm / Ø12"

## Versione 8 sfere composta da:

2 sfere Ø20 cm / Ø8"  
3 sfere Ø25 cm / Ø10"  
3 sfere Ø30 cm / Ø12"

## 6 spheres version composed by:

2 spheres Ø20 cm / Ø8"  
2 spheres Ø25 cm / Ø10"  
2 spheres Ø30 cm / Ø12"

## 8 spheres version composed by:

2 spheres Ø20 cm / Ø8"  
3 spheres Ø25 cm / Ø10"  
3 spheres Ø30 cm / Ø12"

### ! Braccetti non regolabili.

La lampada viene fornita con driver per dimmerazione 1-10V.

In caso di presenza di un diverso sistema di dimmerazione o per connessione con sistema di domotica, si prega di specificare al momento dell'ordine per verificarne la compatibilità.

### ! Non-adjustable arms.

The lamp is supplied with 1-10V driver.

In case of need for different dimmer system or for the connection to home automation system, please inform us prior to ordering for checking compatibility.

### NOTE TECNICHE SUI MATERIALI

**VETRO SOFFIATO A BOCCA** | Piccole variazioni dimensionali sono dovute alla lavorazione artigianale del vetro fuso.

**OTTONE BRUNITO A MANO** | L'ottone brunito a mano è ottenuto da un processo di ossidazione naturale eseguito manualmente. Il risultato di questa lavorazione è un prodotto che può presentare macchie e variazioni di colore che non sono da considerarsi imperfezioni ma caratteristiche che conferiscono ad ogni pezzo una particolare unicità, rendendolo esclusivo.

### TECHNICAL INFORMATION ON THE MATERIALS

**MOUTH\_BLOWN GLASS** | Small dimensional variations are due to the handcrafted processing of molten glass.

**HAND BURNISHED BRASS** | The hand burnished brass is the consequence of hand-made process of natural oxidation. The result of this processing is a product that may show marks and colour variations. These differences are inevitable and should not be considered imperfections but evidence of the hand-crafted process. They enhance the beauty and distinctiveness of a unique piece.



### INFORMAZIONI TECNICHE/ TECHNICAL INFORMATIONS

CTT: 2700K  
CRI: ≥ 80  
Light output: 1200lm (Bolle Tela 6),  
1600lm (Bolle Tela 8)  
Light sources: G4 12V 1,8W each  
Dimmability: 1-10V  
Cable length: 4mt  
Weight: ≈25kg (Bolle Tela 6),  
≈40kg (Bolle Tela 8)



For technical drawing / p. 609

Pricelist 2023 / p. 173  
Homescapes, sense of materials / p. 60  
Homescapes, embracing beauty / p. 25  
Homescapes, gentle attitude / p. 69

### Cm

#### Versione 6 sfere

85 x 70 x 100

#### Versione 8 sfere

85 x 75 x 180

### Inches

#### Version 6 spheres

33½" x 27¾" x 39½"

#### Version 8 spheres

33½" x 29¾" x 71"

### SFERE/SPHERES



Cristallo trasparente soffiato a bocca  
Transparent mouth-blown glass



Cristallo trasparente "ametista"  
"Amethyst" mouth-blown glass

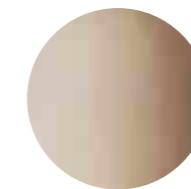

Cristallo trasparente "bronzite"  
"Bronzite" mouth-blown glass

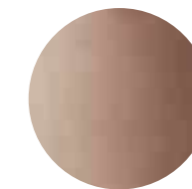

Cristallo trasparente "ametista"  
"Amethyst" mouth-blown glass

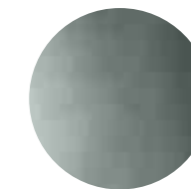

Cristallo trasparente "topazio"  
"Topazio" mouth-blown glass



Ottone brunito a mano  
Hand burnished brass



# Bolle Terra

Massimo Castagna / 2015

Lampada da terra a luce LED dimmerabile. Sfere in cristallo trasparente soffiato a bocca. Disponibile anche versione con sfere colorate in cristallo soffiato a bocca nei colori "topazio", "ambra", "ametista" e "bronzite". Parti metalliche in ottone brunito a mano. Dimmer presente sul cavo di alimentazione.

Floor lamp with dimmable LED light. Transparent mouth-blown glass spheres. Also available version with coloured mouth-blown glass spheres available in "topazio", "ambra", "ametista" and "bronzite" colours. Metal parts in hand burnished brass. Dimmer on the power cable.

Le lampade BOLLE TERRA sono fornite complete di lampadine come servizio di cortesia.

As courtesy BOLLE TERRA lamps are supplied with light bulbs.

**Composta da:**  
2 sfere Ø20 cm / Ø8"  
2 sfere Ø25 cm / Ø10"

**Composed by:**  
2 spheres Ø20 cm / Ø8"  
2 spheres Ø25 cm / Ø10"

! Braccetti non regolabili.

! Non-adjustable arms.

## NOTE TECNICHE SUI MATERIALI

**VETRO SOFFIATO A BOCCA** | Piccole variazioni dimensionali sono dovute alla lavorazione artigianale del vetro fuso.

## TECHNICAL INFORMATION ON THE MATERIALS

**MOUTH\_BLOWN GLASS** | Small dimensional variations are due to the handcrafted processing of molten glass.

**OTTONE BRUNITO A MANO** | L'ottone brunito a mano è ottenuto da un processo di ossidazione naturale eseguito manualmente. Il risultato di questa lavorazione è un prodotto che può presentare macchie e variazioni di colore che non sono da considerarsi imperfezioni ma caratteristiche che conferiscono ad ogni pezzo una particolare unicità, rendendolo esclusivo.

**HAND BURNISHED BRASS** | The hand burnished brass is the consequence of hand-made process of natural oxidation. The result of this processing is a product that may show marks and colour variations. These differences are inevitable and should not be considered imperfections but evidence of the hand-crafted process. They enhance the beauty and distinctiveness of a unique piece.



## INFORMAZIONI TECNICHE/ TECHNICAL INFORMATIONS

CTT: 2700K  
CRI: ≥ 80  
Light output: 800lm  
Light sources: G4 12V 1,8W each  
Dimmability: push button dimmer on the power cable  
Cable length: 2,2mt



[For technical drawing / p. 609](#)

Pricelist 2023 / p. 174  
Homescapes, embracing beauty / pp. 41, 100  
Homescapes, intimate portraits / p. 89

**Cm**  
72 x 68 x 167

**Inches**  
28½" x 27" x 65¾"

## SFERE/SPHERES



**Cristallo trasparente soffiato a bocca**  
Transparent mouth-blown glass



**Cristallo trasparente "ametista"**  
"Amethyst" mouth-blown glass

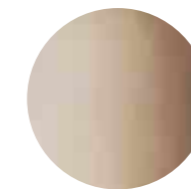

**Cristallo trasparente "bronzite"**  
"Bronzite" mouth-blown glass

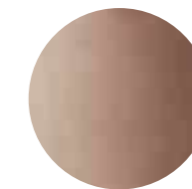

**Cristallo trasparente "ametista"**  
"Amethyst" mouth-blown glass

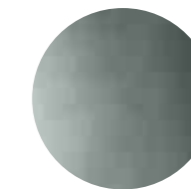

**Cristallo trasparente "topazio"**  
"Topazio" mouth-blown glass



**Ottone brunito a mano**  
Hand burnished brass



# Bolle Verticale

Massimo Castagna / 2022

Lampada telescopica terra-soffitto a luce LED dimmerabile dotata di 7 sfere in cristallo trasparente soffiato a bocca. Disponibile anche versione con sfere colorate in cristallo soffiato a bocca nei colori "topazio", "ambra", "ametista" e "bronzite". Struttura del corpo luce in ottone brunito a mano. Parte telescopica in metallo brunito scuro. Altezza regolabile da 260 a 320cm con sistema di fissaggio a soffitto.

Le lampade BOLLE VERTICALE sono fornite complete di lampadine come servizio di cortesia.

#### Composta da:

1 sfere Ø20 cm / Ø8"  
3 sfere Ø25 cm / Ø10"  
3 sfere Ø30 cm / Ø12"

#### NOTE TECNICHE SUI MATERIALI

**VETRO SOFFIATO A BOCCA** | Piccole variazioni dimensionali sono dovute alla lavorazione artigianale del vetro fuso.

**OTTONE BRUNITO A MANO** | L'ottone brunito a mano è ottenuto da un processo di ossidazione naturale eseguito manualmente. Il risultato di questa lavorazione è un prodotto che può presentare macchie e variazioni di colore che non sono da considerarsi imperfezioni ma caratteristiche che conferiscono ad ogni pezzo una particolare unicità, rendendolo esclusivo.

Telescopic floor to ceiling lamp with dimmable LED light with 7 transparent mouth-blown glass spheres. Also available version with coloured mouth-blown glass spheres available in "topazio", "ambra", "ametista" and "bronzite" colours. Hand burnished brass lighting structure. Telescopic part in dark burnished metal. Adjustable height from 260 to 320cm with ceiling fixing system.

As courtesy BOLLE VERTICALE lamps are supplied with light bulbs.

#### Composed by:

1 sphere Ø20 cm / Ø8"  
3 spheres Ø25 cm / Ø10"  
3 spheres Ø30 cm / Ø12"

#### TECHNICAL INFORMATION ON THE MATERIALS

**MOUTH\_BLOWN GLASS** | Small dimensional variations are due to the handcrafted processing of molten glass.

**HAND BURNISHED BRASS** | The hand burnished brass is the consequence of hand-made process of natural oxidation. The result of this processing is a product that may show marks and colour variations. These differences are inevitable and should not be considered imperfections but evidence of the hand-crafted process. They enhance the beauty and distinctiveness of a unique piece.



#### INFORMAZIONI TECNICHE/ TECHNICAL INFORMATION

CTT: 2700K  
CRI: ≥ 80  
Light output: 700lm  
Light sources: G4 12V 1W each  
Dimmability: Yes  
Cable length: 1,5mt



[For technical drawing / p. 609](#)

[Pricelist 2023 / p. 175](#)  
[Homescapes, gentle attitude / p. 48](#)

#### Cm

65,5 x 69,5 x 260/320

#### Inches

26" x 27½" x 102½"/126"

#### SFERE/SPHERES



Cristallo trasparente soffiato a bocca  
Transparent mouth-blown glass

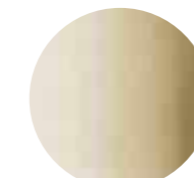

Cristallo trasparente "ametista"  
"Amethyst" mouth-blown glass

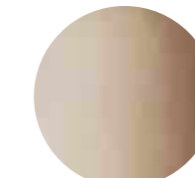

Cristallo trasparente "bronzite"  
"Bronzite" mouth-blown glass



Cristallo trasparente "ametista"  
"Amethyst" mouth-blown glass

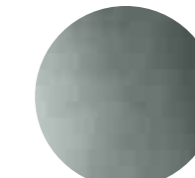

Cristallo trasparente "topazio"  
"Topazio" mouth-blown glass

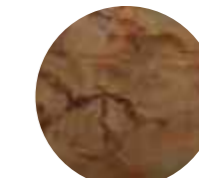

Ottone brunito a mano  
Hand burnished brass

#### PARTI TELESCOPICA/ TELESCOPIC PARTS



Metallo brunito scuro  
Dark burnished metal





▲ **BONFIRE STRIPES**  
Vetro fuso cannettato Calendula (bronzo)  
Calendula (bronze) molten ribbed and curved glass

# Bonfire

Studiopepe / 2020

Lampada a LED da tavolo in vetro fuso curvato. Disponibile anche nella versione "Stripes" in vetro fuso cannettato e curvato. Realizzabile nei colori Calendula (bronzo) e Mirto (verde). Struttura metallica in finitura cromo nero. Cavo elettrico in seta nera 1,5 mt.

## NOTE TECNICHE SUI MATERIALI

**VETRO FUSO** | Eventuali piccole bolle e segni presenti sulla superficie sono dovuti alle lavorazioni del vetro, da non considerarsi difetti. Piccole variazioni dimensionali sono dovute alla lavorazione artigianale del vetro fuso.

LED table lamp made of molten curved glass. Also available in the "Stripes" version with molten ribbed and curved glass. Available in the colours Calendula (bronze) and Mirto (green). Metallic structure in black chrome. 1,5 meter long electric cable in black silk.

## TECHNICAL INFORMATION ON THE MATERIALS

**MOLTEN GLASS** | Any small bubbles and marks present on the surface are due to the production of this type of glass and are therefore not to be considered defects. Small dimensional variations are due to the handcrafted processing of molten glass.

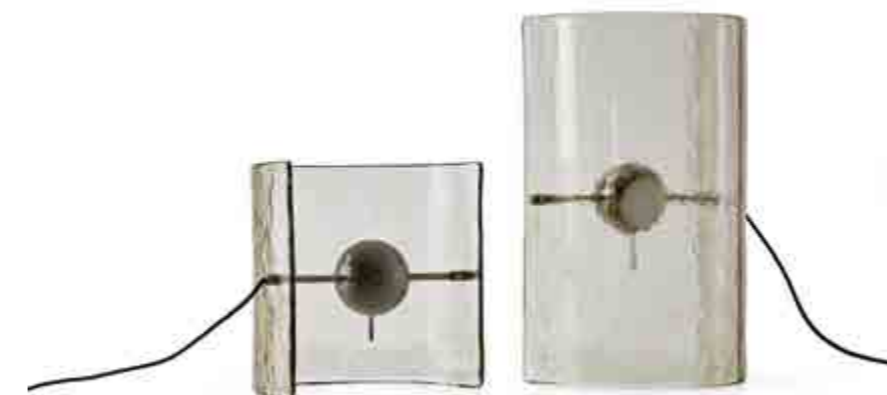

## INFORMAZIONI TECNICHE/ TECHNICAL INFORMATIONS

CTT: 3000K  
CRI: ≥ 80  
Light output: 595lm  
Light sources: LED module 5,8W 500mA  
Dimmability: touch button  
Cable length: 1,5mt



[For technical drawing / p. 610](#)

[Pricelist 2023 / p. 176](#)  
[Homescapes, embracing beauty / p. 96](#)  
[Homescapes, intimate portraits / p. 33](#)  
[Homescapes, gentle attitude / pp. 45, 86, 87](#)

**Cm**  
33 x 20 x 30  
33 x 20 x 50

**Inches**  
13" x 8" x 12"  
13" x 8" x 19¼"

## VETRO FUSO/ MOLTEN GLASS



**Calendula (bronzo)**  
Calendula (bronze)



**Mirto (verde)**  
Mirto (green)

## STRUTTURA/STRUCTURE



**Cromo nero**  
Black chrome

## VETRO FUSO CANNETTATO (Versione stripes)/ MOLTEN RIBBED GLASS (Stripes version)



**Calendula (bronzo)**  
Calendula (bronze)



**Mirto (verde)**  
Mirto (green)



# Diantha

Massimo Castagna / 2017

Lampada a sospensione a luce LED dimmerabile. Cristallo soffiato a bocca e verniciato bronzo. Parti metalliche in nero bronzato.

Hanging lamp with dimmable LED light. Mouth-blown and bronze painted glass. Bronzed black metal parts.

Le lampade DIANTHA sono fornite complete di lampadine come servizio di cortesia.

As courtesy DIANTHA lamps are supplied with light bulbs.

! Versione 220-240V: la lampada viene fornita con driver per dimmerazione in taglio di fase.  
Versione 110V: la lampada viene fornita con driver per dimmerazione 1-10V.

! Version 220-240V: the lamp is supplied with phase-cut driver.  
Version 110V: the lamp is supplied with 1-10V driver.

In caso di presenza di un diverso sistema di dimmerazione o per connessione con sistema di domotica, si prega di specificare al momento dell'ordine per verificarne la compatibilità.

In case of need for different dimmer system or for the connection to home automation system, please inform us prior to ordering for checking compatibility.



• DH



• DVL

	Cm	Inches
DH	157 x 84 x 110	62 " x 33¼" x 43½"
DVS	122 x 123 x 123	48¼" x 48½" x 48½"
DVL	153 x 144 x 220	60¼" x 56¾" x 86¾"

[For technical drawing / p. 610](#)

[Pricelist 2023 / p. 177](#)  
[Homescapes, gentle attitude / pp. 86, 87](#)

## CRISTALLO/GLASS

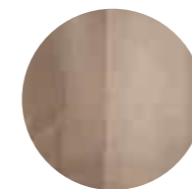

Cristallo soffiato a bocca  
verniciato bronzo  
Mouth blow bronze  
painted glass

## PARTI METALLICHE/ METAL PARTS



Nero bronzato  
Bronzed black

## INFORMAZIONI TECNICHE/ TECHNICAL INFORMATION

CTT: 2700K  
CRI: ≥ 80  
Light output: 1200lm  
Light sources: G4 12V 1,8W each  
Dimmability: phase-cut (220-240V), 1-10V (110V)  
Weight: ≈11kg (DH), ≈17kg (DVS), ≈20kg (DVL)





# Diantha Terra

Massimo Castagna / 2018

Lampada da terra a luce LED dimmerabile. Cristallo soffiato a bocca e verniciato bronzo. Parti metalliche in nero bronzato. Interruttore a pulsante touch posizionato sulla struttura.

Floor lamp with dimmable LED light. Mouth-blown and bronze painted glass. Bronzed black metal parts. Touch button switch positioned on the lamp structure.

Le lampade DIANTHA TERRA sono fornite complete di lampadine come servizio di cortesia.

As courtesy DIANTHA TERRA lamps are supplied with light bulbs.



**Cm**  
104,5 x 80 x 220

**Inches**  
41¼" x 31½" x 87½"

[For technical drawing / p. 610](#)

[Pricelist 2023 / p. 178](#)

## CRISTALLO/GLASS

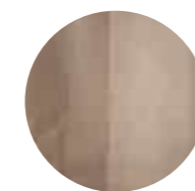

Cristallo soffiato a bocca  
verniciato bronzo  
Mouth blow bronze  
painted glass

## PARTI METALLICHE/ METAL PARTS

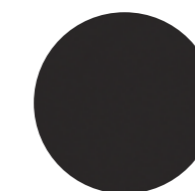

Nero bronzato  
Bronzed black

## INFORMAZIONI TECNICHE/ TECHNICAL INFORMATION

CTT: 2700K  
CRI: ≥ 80  
Light output: 800lm  
Light sources: G4 12V 1,8W each  
Dimmability: touch button  
Cable lenght: 3mt





# Epsilon

Massimo Castagna / 2016

Lampada a sospensione a luce a LED dimmerabile. Cilindri in cristallo sagomato a mano. Parti metalliche in ottone brunito a mano. L'altezza può essere realizzata a misura da un minimo di 115 cm ad un massimo di 450cm.

Le lampade EPSILON sono fornite complete di lampadine come servizio di cortesia.

#### Composta da:

6 cilindri Ø3 x 29 cm / Ø1¼" x 11½"  
6 cilindri Ø3 x 22 cm / Ø1¼" x 8¾"

! **Versione 220-240V:** la lampada viene fornita con driver per dimmerazione in taglio di fase.  
\* **Versione 110V:** la lampada viene fornita con driver per dimmerazione 1-10V.

In caso di presenza di un diverso sistema di dimmerazione o per connessione con sistema di domotica, si prega di specificare al momento dell'ordine per verificarne la compatibilità.

#### NOTE TECNICHE SUI MATERIALI

**OTTONE BRUNITO A MANO** | L'ottone brunito a mano è ottenuto da un processo di ossidazione naturale eseguito manualmente. Il risultato di questa lavorazione è un prodotto che può presentare macchie e variazioni di colore che non sono da considerarsi imperfezioni ma caratteristiche che conferiscono ad ogni pezzo una particolare unicità, rendendolo esclusivo.

Hanging lamp with dimmable LED light. Handshaped glass cylinders. Hand burnished metal parts. The height can be customised from minimum of 115cm to a maximum of 450cm.

As courtesy EPSILON lamps are supplied with light bulbs.

#### Composed by:

6 cylinders Ø3 x 29 cm / Ø1¼" x 11½"  
6 cylinders Ø3 x 22 cm / Ø1¼" x 8¾"

! **Version 220-240V:** the lamp is supplied with phase-cut driver.  
\* **Version 110V:** the lamp is supplied with 1-10V driver.

In case of need for different dimmer system or for the connection to home automation system, please inform us prior to ordering for checking compatibility.

#### TECHNICAL INFORMATION ON THE MATERIALS

**HAND BURNISHED BRASS** | The hand burnished brass is the consequence of hand-made process of natural oxidation. The result of this processing is a product that may show marks and colour variations. These differences are inevitable and should not be considered imperfections but evidence of the hand-crafted process. They enhance the beauty and distinctiveness of a unique piece.



**Cm**  
Ø 100 x 115  
Ø 160 x 115

**Inches**  
Ø 39½" x 45½"  
Ø 63" x 45½"

For technical drawing / p. 611

Pricelist 2023 / p. 179  
Homescapes, gentle attitude / pp. 92, 93

#### CILINDRI/ CYLINDERS



Cristallo sagomato a mano  
Handshaped glass

#### PARTI METALLICHE/ METAL PARTS



Ottone brunito a mano  
Hand burnished brass

#### INFORMAZIONI TECNICHE/ TECHNICAL INFORMATIONS

CTT: 2700K  
CRI: ≥ 80  
Light output: 2400lm  
Light sources: G4 12V 1,8W each  
Dimmability: phase-cut (220-240V), 1-10V (110V)  
Weight: ≈15kg (Ø100cm), ≈26kg (Ø160cm)





# Epsilon Sola

Massimo Castagna / 2017

Lampada a sospensione a luce LED integrata (non dimmerabile). Cilindri in cristallo trasparente sagomato a mano. Parti metalliche in ottone lucido, satinato, brunito a mano, cromato nero o ramato. Rosone in metallo nero bronzato. In dotazione cavo da 4mt per regolare l'altezza. Su richiesta realizzabili set da 3 e 5 lampade con un unico rosone. Questa versione è dimmerabile solo per voltaggio 220-240V.

Hanging lamp with integrated LED light (not dimmable). Handshaped transparent glass cylinders. Bright, satin, hand burnished, black chromed or coppered brass metal parts. Bronzed black metal canopy. Supplied with 4mt long cable to customize height. On request set of 3 or 5 lamps with unique canopy. This version is dimmable only for 220-240V voltage.

#### Rosone unico

##### set 3 pezzi:

2 cilindri Ø6 x 36 cm / Ø2½" x 14¼"

1 cilindro Ø8 x 46 cm / Ø3¼" x 18¼"

#### Rosone unico

##### set 5 pezzi:

3 cilindri Ø6 x 36 cm / Ø2½" x 14¼"

2 cilindri Ø8 x 46 cm / Ø3¼" x 18¼"

#### Unique canopy

##### set of 3 pcs:

2 cylinders Ø6 x 36 cm / Ø2½" x 14¼"

1 cylinder Ø8 x 46 cm / Ø3¼" x 18¼"

#### Unique canopy

##### set of 5 pcs:

3 cylinders Ø6 x 36 cm / Ø2½" x 14¼"

2 cylinders Ø8 x 46 cm / Ø3¼" x 18¼"

! La composizione da 3 e 5 lampade con un unico rosone è dimmerabile solo per voltaggio 220-240V. Questa versione viene fornita con driver per dimmerazione in taglio di fase.

In caso di presenza di un diverso sistema di dimmerazione o per connessione con sistema di domotica, si prega di specificare al momento dell'ordine per verificarne la compatibilità.

! The composition of 3 or 5 lamps with unique canopy is dimmable only for 220-240V voltage. This version is supplied with phase-cut driver.

In case of need for different dimmer system or for the connection to home automation system, please inform us prior to ordering for checking compatibility.

#### NOTE TECNICHE SUI MATERIALI

**OTTONE BRUNITO A MANO** | L'ottone brunito a mano è ottenuto da un processo di ossidazione naturale eseguito manualmente. Il risultato di questa lavorazione è un prodotto che può presentare macchie e variazioni di colore che non sono da considerarsi imperfezioni ma caratteristiche che conferiscono ad ogni pezzo una particolare unicità, rendendolo esclusivo.

#### TECHNICAL INFORMATION ON THE MATERIALS

**HAND BURNISHED BRASS** | The hand burnished brass is the consequence of hand-made process of natural oxidation. The result of this processing is a product that may show marks and colour variations. These differences are inevitable and should not be considered imperfections but evidence of the hand-crafted process. They enhance the beauty and distinctiveness of a unique piece.

	Cm	Inches
S	Ø 6 x 36	Ø 2½" x 14¼"
L	Ø 8 x 46	Ø 3¼" x 18¼"



For technical drawing / p. 611

Pricelist 2023 / p. 180  
Homescapes, intimate portraits / p. 52  
Homescapes, gentle attitude / pp. 52, 55

#### CILINDRI/ CYLINDERS



Cristallo sagomato a mano  
Handshaped glass

#### ROSONE/ CANOPY

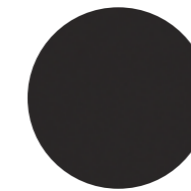

Nero bronzato  
Bronzed black

#### PARTI METALLICHE/ METAL PARTS

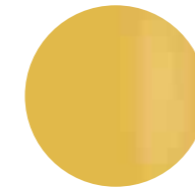

Ottone lucido  
Bright brass

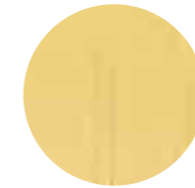

Ottone satinato  
Satin brass



Ottone brunito a mano  
Hand burnished brass

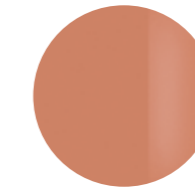

Ottone ramato  
Coppered brass

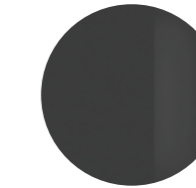

Cromo nero  
Black chrome

#### INFORMAZIONI TECNICHE/ TECHNICAL INFORMATIONS

CTT: 2700K

CRI: ≥ 80

Light output: 357lm

Light sources: LED spot 3,15W 350mA (costant current)

Dimmability: NO - Dimmable phase-cut just for 3-5 lamps version (only for 220-240V)

Cable lenght: 4mt

Weight: ≈3kg





# Eris

Massimo Castagna / 2017

Lampada a sospensione a luce LED non dimmerabile con struttura verniciata nero bronzato e fasce in ottone lucido, satinato, brunito a mano e cromato nero.

Hanging lamp with LED light (not dimmable) with black bronzed painted structure and bright, satin, hand-burnished and black chromed brass parts.

## NOTE TECNICHE SUI MATERIALI

**OTTONE BRUNITO A MANO** | L'ottone brunito a mano è ottenuto da un processo di ossidazione naturale eseguito manualmente. Il risultato di questa lavorazione è un prodotto che può presentare macchie e variazioni di colore che non sono da considerarsi imperfezioni ma caratteristiche che conferiscono ad ogni pezzo una particolare unicità, rendendolo esclusivo.

## TECHNICAL INFORMATION ON THE MATERIALS

**HAND BURNISHED BRASS** | The hand burnished brass is the consequence of hand-made process of natural oxidation. The result of this processing is a product that may show marks and colour variations. These differences are inevitable and should not be considered imperfections but evidence of the hand-crafted process. They enhance the beauty and distinctiveness of a unique piece.



### Cm

Ø 35 x 180  
Ø 35 x 210  
Ø 35 x 250  
Ø 35 x 280  
Ø 35 x 320

### Inches

Ø 14" x 71"  
Ø 14" x 82¾"  
Ø 14" x 98½"  
Ø 14" x 110¼"  
Ø 14" x 126"

For technical drawing / p. 611

Pricelist 2023 / p. 181  
Homescapes, sense of materials / p. 18

## STRUTTURA/STRUCTURE

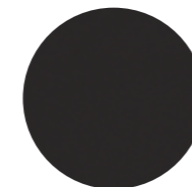

Nero bronzato  
Black bronzed

## FASCE/PARTS



Ottone lucido  
Bright brass



Ottone satinato  
Satin brass



Ottone brunito a mano  
Hand burnished brass



Cromo nero  
Black chrome

## INFORMAZIONI TECNICHE/ TECHNICAL INFORMATIONS

CTT: 3000K  
CRI: ≥ 80  
Light output: 4680lm  
Light sources: LED stripe/integrated: 57,6W (19,2W/mt x 3mt), 1560lm/mt x3  
Dimmability: NO  
Weight: ≈30kg





# Jolie

Federica Biasi / 2019

Lampada a sospensione a luce LED dimmerabile composta da due calotte in vetro di Murano soffiato a bocca. Dettagli metallici in ottone satinato. Disponibile anche versione con dettagli metallici in ottone brunito scuro. In dotazione cavo da 4 mt per regolare l'altezza.

## NOTE TECNICHE SUI MATERIALI

**VETRO DI MURANO** | Eventuali piccole bolle e segni presenti sulla superficie sono dovuti alle lavorazioni del vetro, da non considerarsi difetti.

! La lampada viene fornita con driver per dimmerazione 1-10V.

In caso di presenza di un diverso sistema di dimmerazione o per connessione con sistema di domotica, si prega di specificare al momento dell'ordine per verificarne la compatibilità.

Hanging lamp with dimmable LED light composed by two dome shaped sections in Murano's mouth-blown glass. Satin brass metal details. Also available version with dark burnished brass metal details. Supplied with cable 4mt long to customize height.

## TECHNICAL INFORMATION ON THE MATERIALS

**MURANO'S GLASS** | Any small bubbles and marks present on the surface are due to the production of this type of glass and are therefore not to be considered defects.

! The lamp is supplied with 1-10V driver.

In case of need for different dimmer system or for the connection to home automation system, please inform us prior to ordering for checking compatibility.



**Cm**  
Ø 60 x 62

**Inches**  
Ø 23¾" x 24½"

[For technical drawing / p. 612](#)

Pricelist 2023 / p. 182  
Homescapes, sense of materials / p. 18  
Homescapes, gentle attitude / pp. 28, 30

## VETRO/GLASS

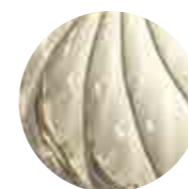

Vetro di Murano  
soffiato a bocca  
Murano's mouth-blown  
glass

## DETTAGLI/DETAILS



Ottone satinato  
Satin brass

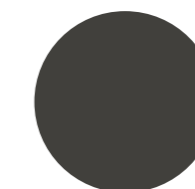

Ottone brunito scuro  
Dark burnished brass

## INFORMAZIONI TECNICHE/ TECHNICAL INFORMATIONS

CTT: 3200K  
CRI: ≥ 90  
Light output: 1800lm  
Light sources: LED module 15W  
Dimmability: 1-10V  
Cable length: 4mt  
Weight: ≈15kg





# Jolie Applique

Federica Biasi / 2019

Applique in cristallo soffiato a bocca. Dettagli metallici in ottone satinato. Luce LED (non dimmerabile). Disponibile anche versione con dettagli metallici in ottone brunito scuro.

Wall light in mouth-blown glass. Satin brass metal details. LED light (not dimmable). Also available version with dark burnished brass metal details.

## NOTE TECNICHE SUI MATERIALI

VETRO SOFFIATO A BOCCA | Eventuali piccole bolle e segni presenti sulla superficie sono dovuti alle lavorazioni del vetro, da non considerarsi difetti.

## TECHNICAL INFORMATION ON THE MATERIALS

MOUTH\_BLOWN GLASS | Any small bubbles and marks present on the surface are due to the production of this type of glass and are therefore not to be considered defects.

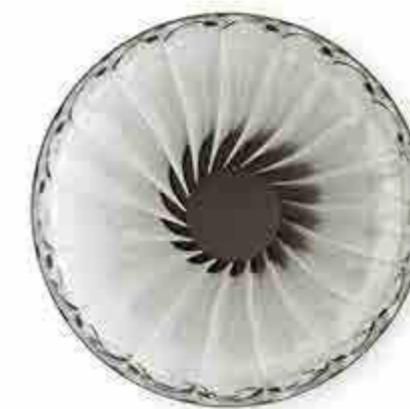

**Cm**  
 Ø 20 x 11  
 Ø 30 x 15

**Inches**  
 Ø 8" x 4½"  
 Ø 12" x 6"

[For technical drawing / p. 612](#)

Pricelist 2023 / p. 183  
 Homescapes, sense of materials / p. 74  
 Homescapes, gentle attitude / pp. 16, 17, 28, 29

## VETRO/GLASS



Cristallo soffiato a bocca  
 Mouth-blown glass

## DETTAGLI/DETAILS



Ottone satinato  
 Satin brass

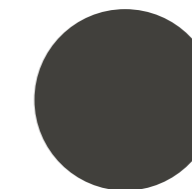

Ottone brunito scuro  
 Dark burnished brass

## INFORMAZIONI TECNICHE/ TECHNICAL INFORMATIONS

CTT: 3000K  
 CRI: ≥ 80  
 Light output: 1000lm  
 Light sources: LED module 7,8W  
 Dimmability: NO







# Key-to-Heaven

Massimo Castagna / 2022

Lampada a sospensione a luce LED (non dimmerabile). Parti metalliche in ottone satinato oppure in metallo laccato color brunito scuro. In dotazione cavo di 4mt per regolare l'altezza.

Hanging lamp with LED light (not dimmable). Satin or dark burnished lacquered metal parts. Supplied with cable 4mt long to customize height.

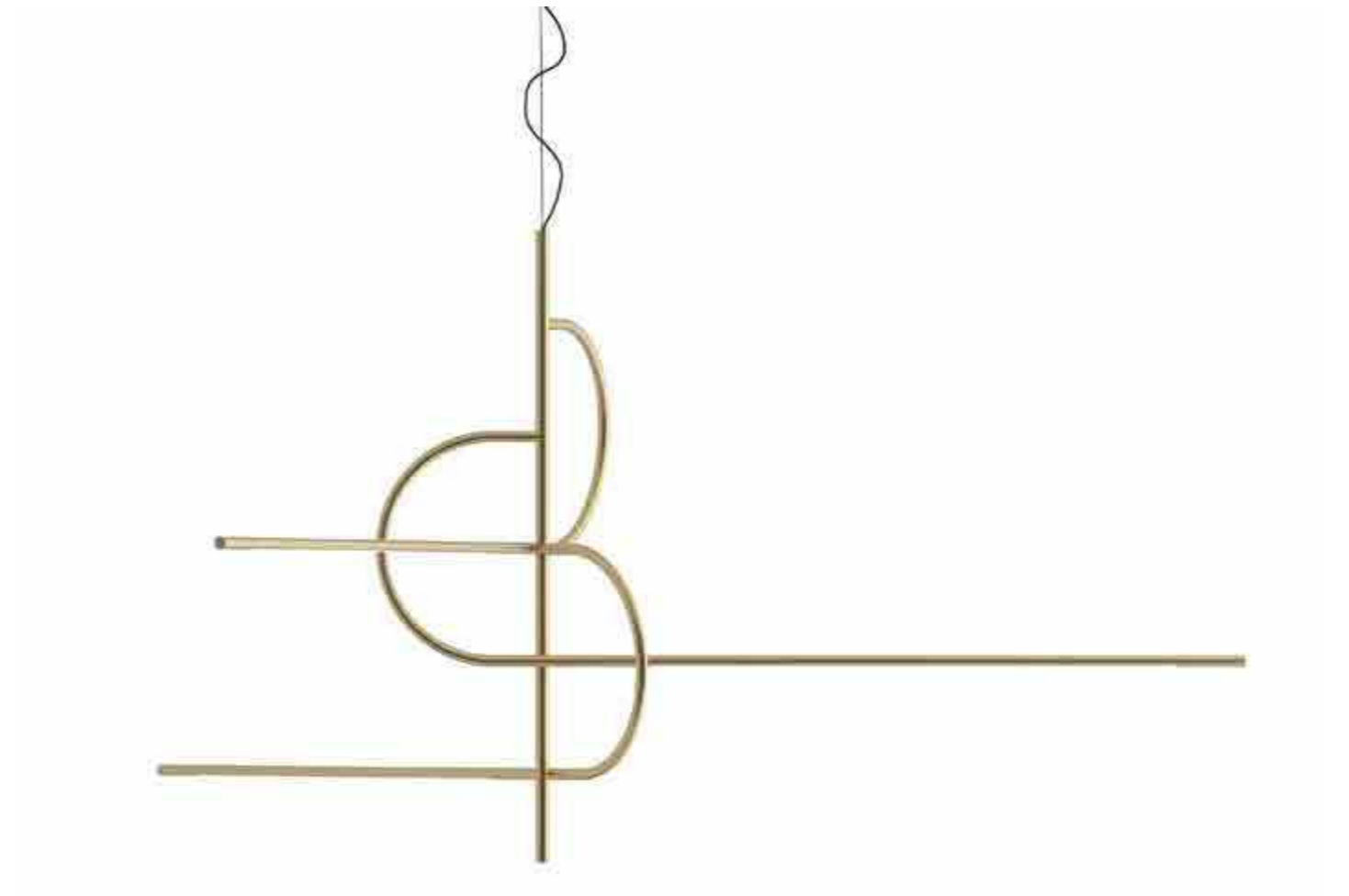

**Cm**  
233 x 204 x 120

**Inches**  
9 1/4" x 80 1/2" x 47 1/4"

[For technical drawing / p. 612](#)

[Pricelist 2023 / p. 184](#)  
[Homescapes, gentle attitude / pp. 72, 73, 76, 77](#)

## PARTI METALLICHE/ METAL PARTS



Ottone satinato  
Satin brass

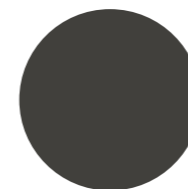

Metallo laccato color brunito  
Dark burnished lacquered metal

## INFORMAZIONI TECNICHE/ TECHNICAL INFORMATION

CTT: 2700K  
CRI: ≥ 80  
Light output: 1081lm  
Light sources: LED stripe/integrated: 11,5W  
Dimmability: NO





# Key-to-Heaven Fix

Massimo Castagna / 2022

Lampada a sospensione a luce LED (non dimmerabile). Struttura a 4 vie in metallo laccato color brunito scuro. Disponibile in 3 altezze predefinite.

Hanging lamp with LED light (not dimmable). Dark burnished lacquered metal structure with 4 arms. Available in three standard heights.



#### Cm

158 x 79 x 115  
158 x 79 x 145  
158 x 79 x 175

#### Inches

62¼" x 31¼" x 45½"  
62¼" x 31¼" x 57¼"  
62¼" x 31¼" x 69"

[For technical drawing / p. 613](#)

[Pricelist 2023 / p. 185](#)  
[Homescapes, gentle attitude / pp. 72, 73, 76, 77](#)

#### STRUTTURA/ STRUCTURE

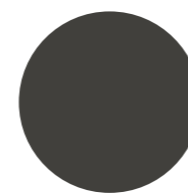

Metallo laccato color brunito scuro  
Dark burnished lacquered metal

#### INFORMAZIONI TECNICHE/ TECHNICAL INFORMATION

CTT: 2700K  
CRI: ≥ 80  
Light output: 1081lm  
Light sources: LED stripe/integrated: 11,5W  
Dimmability: NO





# Narghilé

Massimo Castagna / 2018

Lampada a sospensione a luce LED non dimmerabile. Cilindri in cristallo trasparente sagomato a mano. Parti metalliche in ottone cromato lucido. Rosone in metallo verniciato bianco. In dotazione cavo di 4mt per regolare l'altezza. Su richiesta set da 4 e 6 lampade con un unico rosone. Questa versione è dimmerabile solo per voltaggio 220-240V.

Hanging lamp with LED light (not dimmable). Handshaped transparent glass cylinders. Bright chromed brass metal parts. White painted metal canopy. Supplied with cable 4mt long to customize height. On request set of 4 or 6 lamps with unique canopy. This version is dimmable only for 220-240V voltage.

! Disponibile fino ad esaurimento scorte.

La composizione da 4 e 6 lampade con un unico rosone è dimmerabile solo per voltaggio 220-240V. Questa versione viene fornita con driver per dimmerazione in taglio di fase.

In caso di presenza di un diverso sistema di dimmerazione o per connessione con sistema di domotica, si prega di specificare al momento dell'ordine per verificarne

! Available while stock lasts.

The composition of 4 or 6 lamps with unique canopy is dimmable only for 220-240V voltage. This version is supplied with phase-cut driver.

In case of need for different dimmer system or for the connection to home



## Cm

Ø 30 x 79

Ø 30 x 98

## Rosone

36 x 36 x 4 | singola

72 x 72 x 4 | 4 pezzi

72 x 108 x 4 | 6 pezzi

## Inches

Ø 12" x 31¼"

Ø 12" x 38¾"

## Canopy

14¼" x 14¼" x 1¼" | single

28½" x 28½" x 1¼" | 4 pieces

28½" x 42¾" x 1¼" | 6 pieces

[For technical drawing / p. 613](#)

[Pricelist 2023 / p. 186](#)  
[Homescapes, sense of materials / p. 51](#)  
[Homescapes, gentle attitude / pp. 98, 99](#)

## CILINDRI/ CYLINDERS



Cristallo trasparente sagomato a mano  
Handshaped transparent glass

## PARTI METALLICHE/ METAL PARTS



Ottone cromato lucido  
Bright chromed brass

## ROSONE/CANOPY



Metallo verniciato bianco  
White painted metal

## INFORMAZIONI TECNICHE/ TECHNICAL INFORMATIONS

CTT: 2700K

CRI: ≥ 80

Light output: 357lm

Light sources: LED spot 3,15W 350mA (costant current)

Dimmability: NO - Dimmable phase-cut just for 4-6 lamps version (only for 220-240V)

Cable lenght: 4mt

Weight: ≈40kg





# Ori

Massimo Castagna / 2017

Applique in ottone satinato all'esterno e lucido all'interno. Disponibile anche nella versione in ottone brunito a mano "dark" all'esterno e ottone lucido all'interno. Lampada a LED non dimmerabile.

Wall lamp in satin brass outside and bright brass inside. Also available in the version in "dark" hand burnished brass outside and bright brass inside. LED light (not dimmable).



**Cm**  
18 x 5 x 48

**Inches**  
7 1/4" x 2" x 19"

[For technical drawing / p. 613](#)

[Pricelist 2023 / p. 187](#)  
[Homescapes, intimate portraits / p. 82](#)

STRUTTURA ESTERNA/  
OUTSIDE STRUCTURE

STRUTTURA INTERNA/  
INSIDE STRUCTURE

STRUTTURA ESTERNA/  
OUTSIDE STRUCTURE

STRUTTURA INTERNA/  
INSIDE STRUCTURE

INFORMAZIONI TECNICHE/  
TECHNICAL INFORMATIONS



Ottone satinato  
Satin brass



Ottone lucido  
Bright brass



Ottone brunito a  
mano "dark"  
"Dark" hand burnished brass



Ottone lucido  
Bright brass

CTT: 4000K  
CRI: ≥ 80  
Light output: 1500lm  
Light sources: LED stripe/integrated: 2x5W 24Vdc  
Dimmability: NO  
Weight: ≈7kg





# Spectrum

Studiopepe / 2021

Lampada a sospensione a luce NEON dimmerabile solo nella versione 220/240V. Fonte luminosa in Neon curvato a caldo. Struttura in ottone brunito a mano. In dotazione cavo da 4mt per regolare l'altezza. Disponibile in due dimensioni e due diverse configurazioni del NEON.

! La lampada è dimmerabile solo per voltaggio 220-240V. Questa versione viene fornita con driver per dimmerazione in taglio di fase.

In caso di presenza di un diverso sistema di dimmerazione o per connessione con sistema di domotica, si prega di specificare al momento dell'ordine per verificarne la compatibilità.

## NOTE TECNICHE SUI MATERIALI

**OTTONE BRUNITO A MANO** | L'ottone brunito a mano è ottenuto da un processo di ossidazione naturale eseguito manualmente. Il risultato di questa lavorazione è un prodotto che può presentare macchie e variazioni di colore che non sono da considerarsi imperfezioni ma caratteristiche che conferiscono ad ogni pezzo una particolare unicità, rendendolo esclusivo.

Hanging lamp with NEON light, dimmable just for version 220/240V. Light source in hot-bent NEON. Hand burnished brass structure. Supplied with cable 4 meters long to customize height. Available in two dimensions and two different configurations of the NEON.

! The lamp is dimmable only for 220-240V voltage. This version is supplied with phase-cut driver.

In case of need for different dimmer system or for the connection to home automation system, please inform us prior to ordering for checking compatibility.

## TECHNICAL INFORMATION ON THE MATERIALS

**HAND BURNISHED BRASS** | The hand burnished brass is the consequence of hand-made process of natural oxidation. The result of this processing is a product that may show marks and colour variations. These differences are inevitable and should not be considered imperfections but evidence of the hand-crafted process. They enhance the beauty and distinctiveness of a unique piece.



	Cm	Inches
A	64,5 x 56 x 79	25½" x 22¼" x 31¼"
	97,5 x 84,5 x 114	38½" x 33½" x 45"
B	64,5 x 56 x 79	25½" x 22¼" x 31¼"
	97,5 x 84,5 x 114	38½" x 33½" x 45"

[For technical drawing / p. 614](#)

[Pricelist 2023 / p. 188](#)  
[Homescapes, intimate portraits/ p. 28](#)  
[Homescapes, gentle attitude / pp. 24, 25, 90](#)

## STRUTTURA/STRUCTURE



Ottone brunito a mano  
Hand burnished brass

## INFORMAZIONI TECNICHE/ TECHNICAL INFORMATIONS

CTT: 2800K  
 CRI: ≥ 80  
 Light output: 1680lm (79h version) 3410lm (114h version)  
 Light sources:  
 hot-bent NEON 22W, 1,4mt Ø15mm(79h version)  
 hot-bent NEON 39W, 2,2mt Ø18mm(114h version)  
 Dimmability: phase-cut (only for 220-240V)  
 Cable length: 4mt  
 Weight: ≈20kg (79h version), ≈22kg (114h version)



# 14

**Lampade / Lightings**  
**TECHNICAL MODULE**

## GENERAL INDICATION

220-240V EU - UK	CCT (K)	CRI	Light output (lm)	Light sources	Dimmability
Bolle 4	2700K	≥ 80	800lm	n.4 G4 12V 1,8W each (7,2W totally)	phase-cut
Bolle 6	2700K	≥ 80	1200lm	n.6 G4 12V 1,8W each (10,8W totally)	phase-cut
Bolle Aria	2700K	≥ 80	600lm	n.3 G4 12V 1,8W each (5,4W)	phase-cut
Bolle Cielo	2700K	≥ 80	1200lm 1800lm	n.6 G4 12V 1,8W each (10,8W totally) n.9 G4 12V 1,8W each (16,2W totally)	phase-cut
Bolle Orizzontale	2700K	≥ 80	2000lm 3200lm	n.10 G4 12V 1,8W each (18W totally) n.16 G4 12V 1,8W each (28,8W totally)	1 - 10 V
Bolle Sola	2700K	≥ 80	200lm	n.1 G4 12V 1,8W each	1 lamp version: NO   3/5 lamps version: phase-cut
Bolle Stelo	2700K	≥ 80	800lm	n.7 G4 12V 1W each (7W totally)	YES
Bolle Tavolo 1	2700K	≥ 80	200lm	n.1 G4 12V 1,8W each	NO
Bolle Tavolo 3	2700K	≥ 80	600lm	n.3 G4 12V 1,8W each (5,4W)	YES
Bolle Tela	2700K	≥ 80	1200lm 1600lm	n.6 G4 12V 1,8W each (10,8W totally) n.8 G4 12V 1,8W each (14,4W totally)	1 - 10 V
Bolle Terra	2700K	≥ 80	800lm	n.4 G4 12V 1,8W each (7,2W totally)	YES
Bolle Verticale	2700K	≥ 80	700lm	n.7 G4 12V 1W each (7W totally)	YES
Bonfire	3000K	≥ 80	595lm	LED module 5,8W 500mA	YES
Diantha	2700K	≥ 80	1200lm	n.6 G4 12V 1,8W each (10,8W totally)	phase-cut
Diantha Terra	2700K	≥ 80	800lm	n.4 G4 12V 1,8W each (7,2W totally)	YES
Epsilon	2700K	≥ 80	2400lm	n.12 G4 12V 1,8W each (21,6W totally)	phase-cut
Epsilon Sola	2700K	≥ 80	357lm	LED Spot: 3,15W 350mA (constant current)	1 lamp version: NO   3/5 lamps version: phase-cut
Eris	3000K	≥ 80	4680lm	LED Stripe/integrated: 57,6W (19,2W/ mt x 3mt) (1560lm/mt x 3)	NO
Jolie	3000K	≥ 90	1800lm	LED module 15W	1 - 10 V
Jolie Applique	3000K	≥ 80	1000lm	LED module 7,8W	NO
Key-to-Heaven	2700K	≥ 80	1081lm	LED Stripe/integrated: 11,5W	NO
Key-to-Heaven Fix	2700K	≥ 80	1081lm	LED Stripe/integrated: 11,5W	NO
Narghilè	2700K	≥ 80	357lm	LED Spot: 3,15W 350mA (constant current)	1 lamp version: NO   4/6 lamps version: phase-cut
Ori	4000K	≥ 80	1500lm	LED Stripe/integrated: 2x5W 24Vdc	NO
Spectrum	2800K	≥ 80	3410lm 1680lm	39W (2,2 mt, Ø18 mm) 22W (1,4 mt, Ø15 mm)	phase-cut

## GENERAL INDICATION

110V USA	CCT (K)	CRI	Light output (lm)	Light sources	Dimmability
Bolle 4	2700K	≥ 80	800lm	n.4 G4 12V 1,8W each (7,2W totally)	1 - 10 V
Bolle 6	2700K	≥ 80	1200lm	n.6 G4 12V 1,8W each (10,8W totally)	1 - 10 V
Bolle Aria	2700K	≥ 80	600lm	n.3 G4 12V 1,8W each (5,4W)	1 - 10 V
Bolle Cielo	2700K	≥ 80	1200lm 1800lm	n.6 G4 12V 1,8W each (10,8W totally) n.9 G4 12V 1,8W each (16,2W totally)	1 - 10 V
Bolle Orizzontale	2700K	≥ 80	2000lm 3200lm	n.10 G4 12V 1,8W each (18W totally) n.16 G4 12V 1,8W each (28,8W totally)	1 - 10 V
Bolle Sola	2700K	≥ 80	200lm	n.1 G4 12V 1,8W each	NO
Bolle Stelo	2700K	≥ 80	800lm	n.7 G4 12V 1W each (7W totally)	YES
Bolle Tavolo 1	2700K	≥ 80	200lm	n.1 G4 12V 1,8W each	NO
Bolle Tavolo 3	2700K	≥ 80	600lm	n.3 G4 12V 1,8W each (5,4W)	YES
Bolle Tela	2700K	≥ 80	1200lm 1600lm	n.6 G4 12V 1,8W each (10,8W totally) n.8 G4 12V 1,8W each (14,4W totally)	1 - 10 V
Bolle Terra	2700K	≥ 80	800lm	n.4 G4 12V 1,8W each (7,2W totally)	YES
Bolle Verticale	2700K	≥ 80	700lm	n.7 G4 12V 1W each (7W totally)	YES
Bonfire	3000K	≥ 80	595lm	LED module 5,8W 500mA	YES
Diantha	2700K	≥ 80	1200lm	n.6 G4 12V 1,8W each (10,8W totally)	1 - 10 V
Diantha Terra	2700K	≥ 80	800lm	n.4 G4 12V 1,8W each (7,2W totally)	1 - 10 V
Epsilon	2700K	≥ 80	2400lm	n.12 G4 12V 1,8W each (21,6W totally)	1 - 10 V
Epsilon Sola	2700K	≥ 80	357lm	LED Spot: 3,15W 350mA (constant current)	NO
Eris	3000K	≥ 80	4680lm	LED Stripe/integrated: 57,6W (19,2W/ mt x 3mt) (1560lm/mt x 3)	NO
Jolie	3000K	≥ 90	1800lm	LED module 15W	1 - 10 V
Jolie Applique	3000K	≥ 80	1000lm	LED module 7,8W	NO
Key-to-Heaven	2700K	≥ 80	1081lm	LED Stripe/integrated: 11,5W	NO
Key-to-Heaven Fix	2700K	≥ 80	1081lm	LED Stripe/integrated: 11,5W	NO
Narghilè	2700K	≥ 80	357lm	LED Spot: 3,15W 350mA (constant current)	NO
Ori	4000K	≥ 80	1500lm	LED Stripe/integrated: 2x5W 24Vdc	NO
Spectrum	2800K	≥ 80	3410lm 1680lm	39W (2,2 mt, Ø18 mm) 22W (1,4 mt, Ø15 mm)	NO

**Bolle 4** | Massimo Castagna, 2014

Product information / p. 552

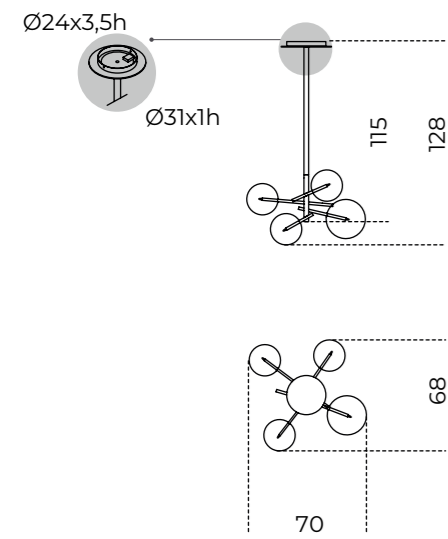

**Composta da:**  
2 sfere  $\text{Ø}20$  cm  
2 sfere  $\text{Ø}25$  cm

**Composed by:**  
2 spheres  $\text{Ø}8''$   
2 spheres  $\text{Ø}10''$

**Bolle 6** | Massimo Castagna, 2014

Product information / p. 554

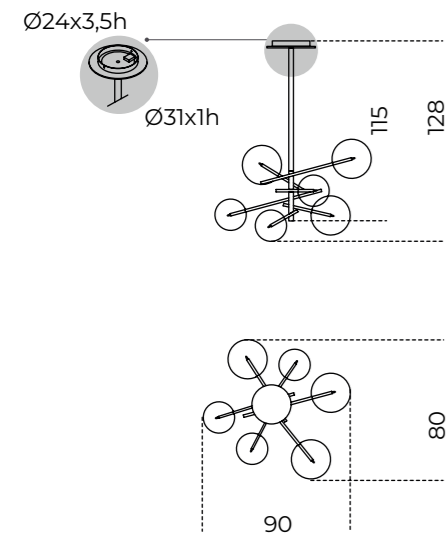

**Composta da:**  
3 sfere  $\text{Ø}20$  cm  
3 sfere  $\text{Ø}25$  cm

**Composed by:**  
3 spheres  $\text{Ø}8''$   
3 spheres  $\text{Ø}10''$

**Esempio di installazione**  
Installation example

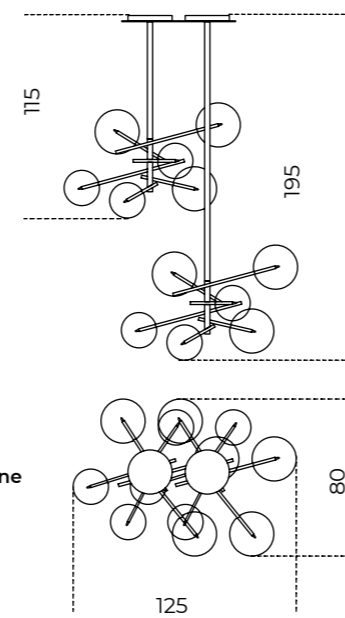

**Bolle Aria** | Massimo Castagna, 2020

Product information / p. 556

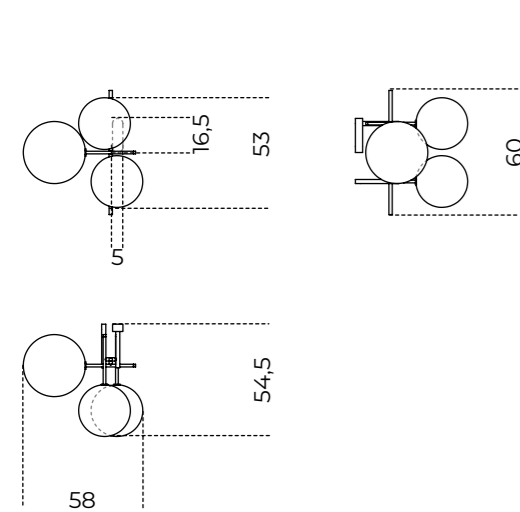

**USA Version**

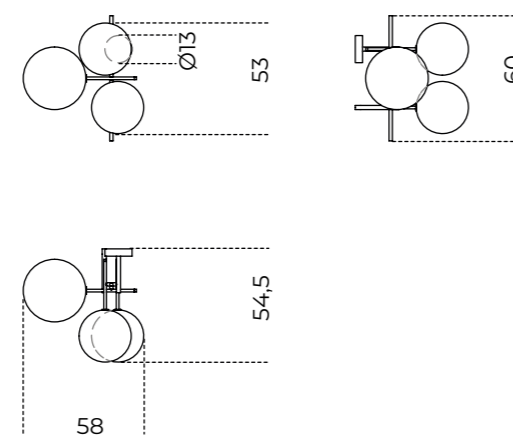

**Composta da:**  
2 sfere  $\text{Ø}25$  cm  
1 sfera  $\text{Ø}30$  cm

**Composed by:**  
2 spheres  $\text{Ø}10''$   
1 sphere  $\text{Ø}12''$

**Bolle Cielo** | Massimo Castagna, 2020

Product information / p. 558

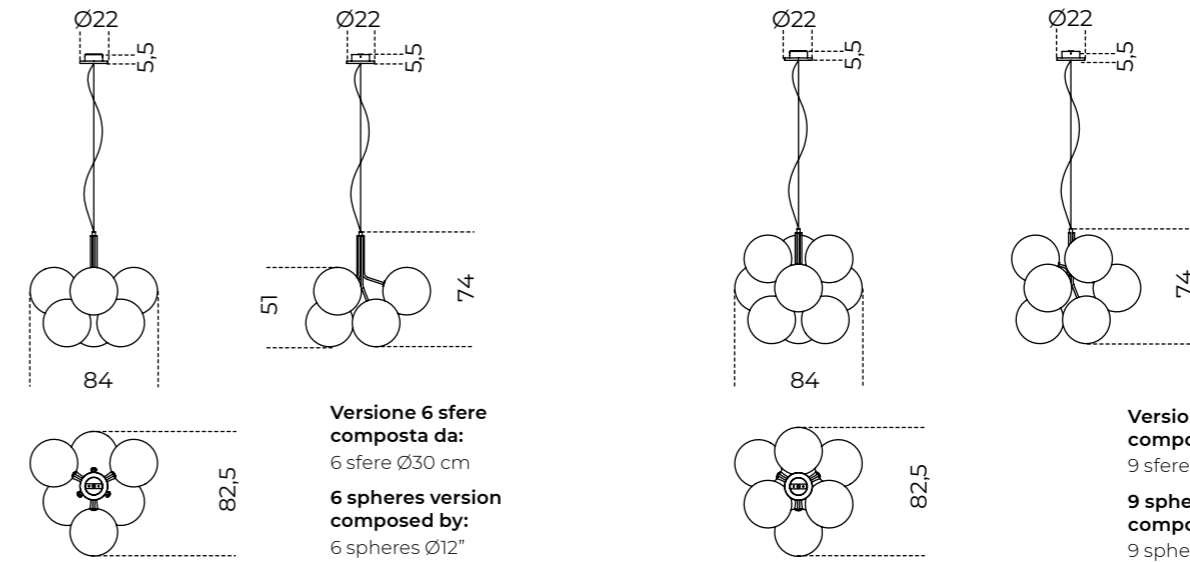

**Versione 6 sfere**  
**composta da:**  
6 sfere  $\text{Ø}30$  cm

**6 spheres version**  
**composed by:**  
6 spheres  $\text{Ø}12''$

**Versione 9 sfere**  
**composta da:**  
9 sfere  $\text{Ø}30$  cm

**9 spheres version**  
**composed by:**  
9 spheres  $\text{Ø}12''$

**Bolle Orizzontale** | Massimo Castagna, 2019

Product information / p. 560

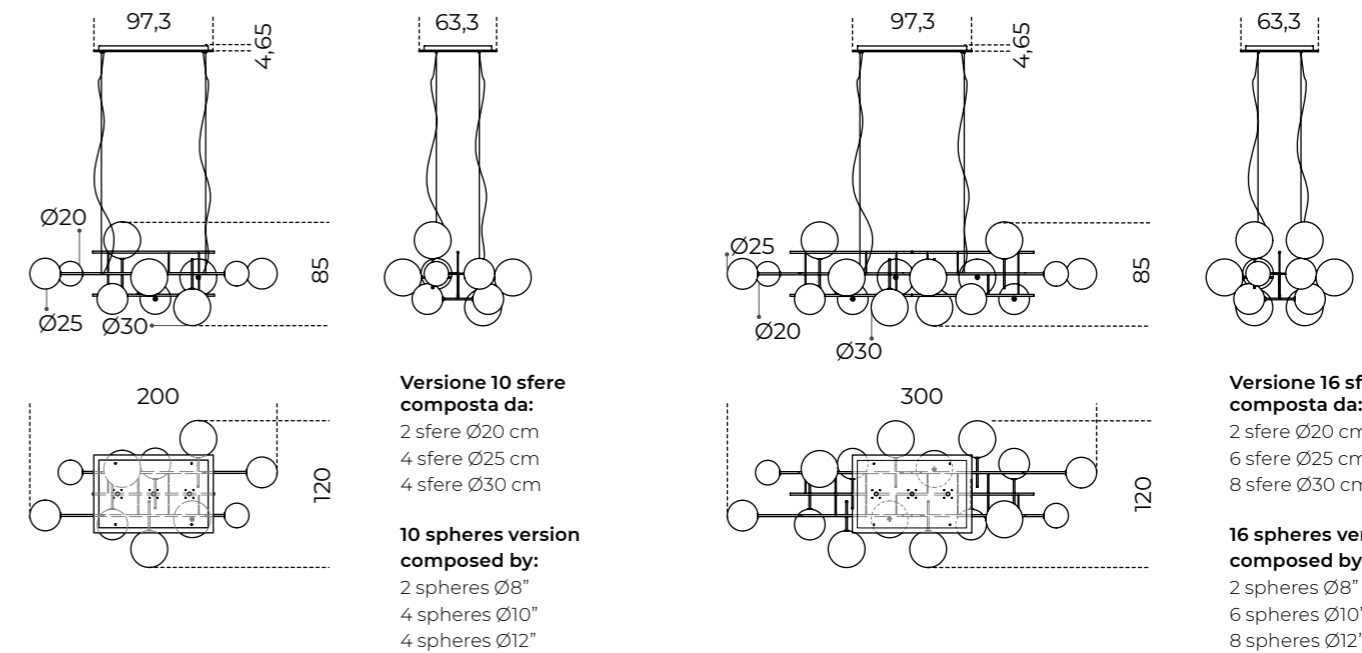

**Versione 10 sfere**  
**composta da:**  
2 sfere  $\text{Ø}20$  cm  
4 sfere  $\text{Ø}25$  cm  
4 sfere  $\text{Ø}30$  cm

**10 spheres version**  
**composed by:**  
2 spheres  $\text{Ø}8''$   
4 spheres  $\text{Ø}10''$   
4 spheres  $\text{Ø}12''$

**Versione 16 sfere**  
**composta da:**  
2 sfere  $\text{Ø}20$  cm  
6 sfere  $\text{Ø}25$  cm  
8 sfere  $\text{Ø}30$  cm

**16 spheres version**  
**composed by:**  
2 spheres  $\text{Ø}8''$   
6 spheres  $\text{Ø}10''$   
8 spheres  $\text{Ø}12''$

**Bolle Sola** | Massimo Castagna, 2019

Product information / p. 562

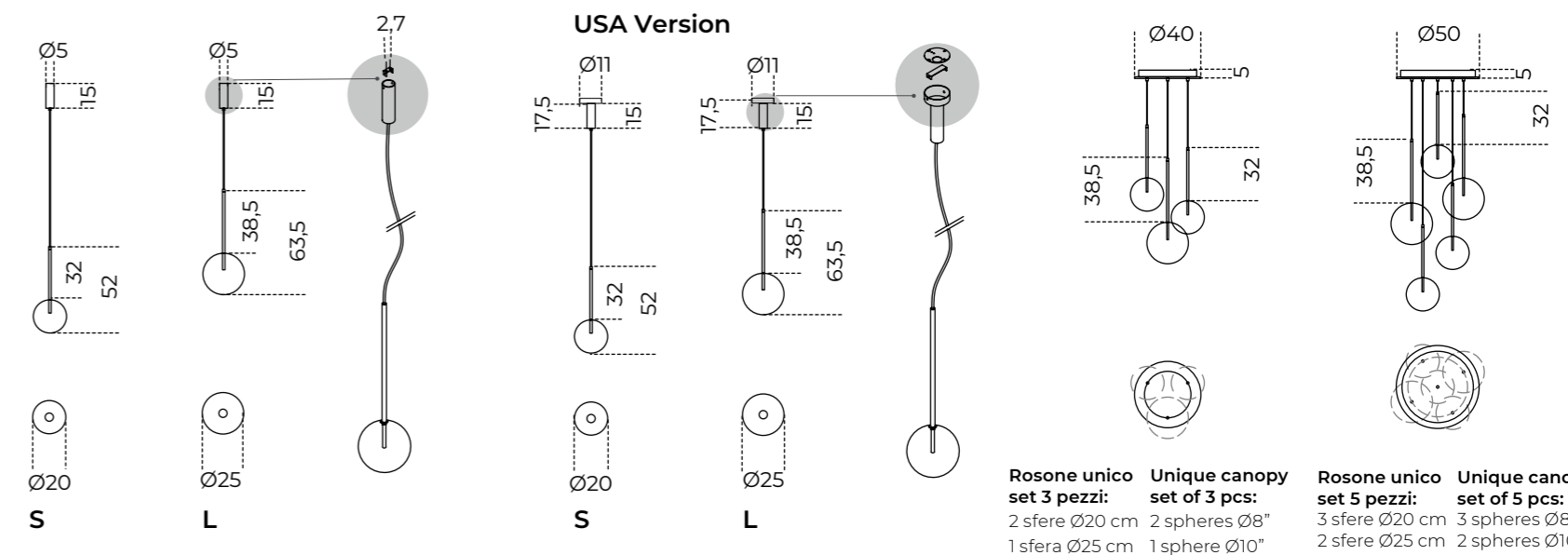

**USA Version**

**Rosone unico**  
**set 3 pezzi:**  
2 sfere  $\text{Ø}20$  cm  
1 sfera  $\text{Ø}25$  cm

**Unique canopy**  
**set of 3 pcs:**  
2 spheres  $\text{Ø}8''$   
1 sphere  $\text{Ø}10''$

**Rosone unico**  
**set 5 pezzi:**  
3 sfere  $\text{Ø}20$  cm  
2 sfere  $\text{Ø}25$  cm

**Unique canopy**  
**set of 5 pcs:**  
3 spheres  $\text{Ø}8''$   
2 spheres  $\text{Ø}10''$



**Bolle Stelo** | Massimo Castagna, 2024

Product information / p. 564

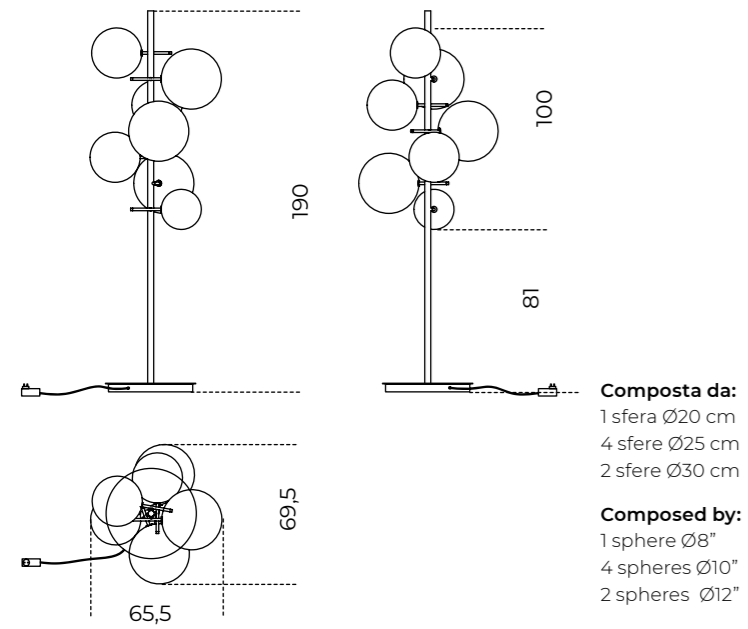
**Bolle Tela** | Massimo Castagna, 2018

Product information / p. 570

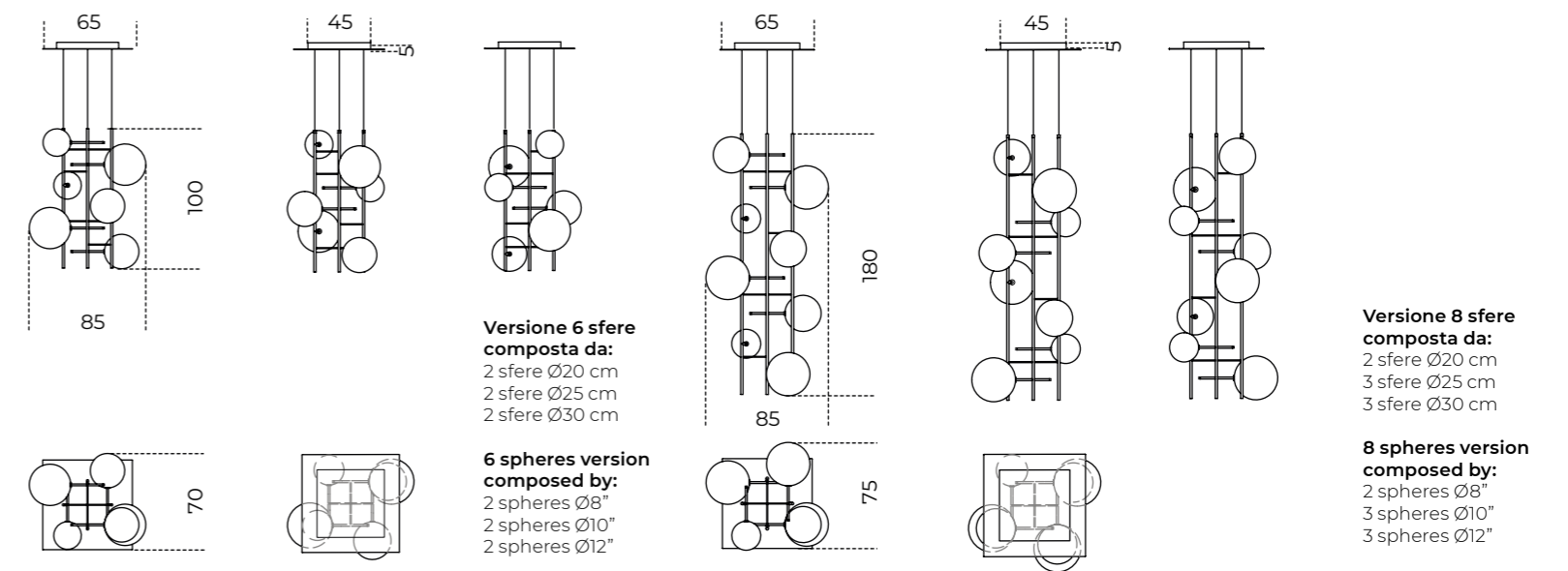
**Bolle Tavolo 1** | Massimo Castagna, 2015

Product information / p. 566

**Bolle Terra** | Massimo Castagna, 2015

Product information / p. 572

**Bolle Tavolo 3** | Massimo Castagna, 2015

Product information / p. 568

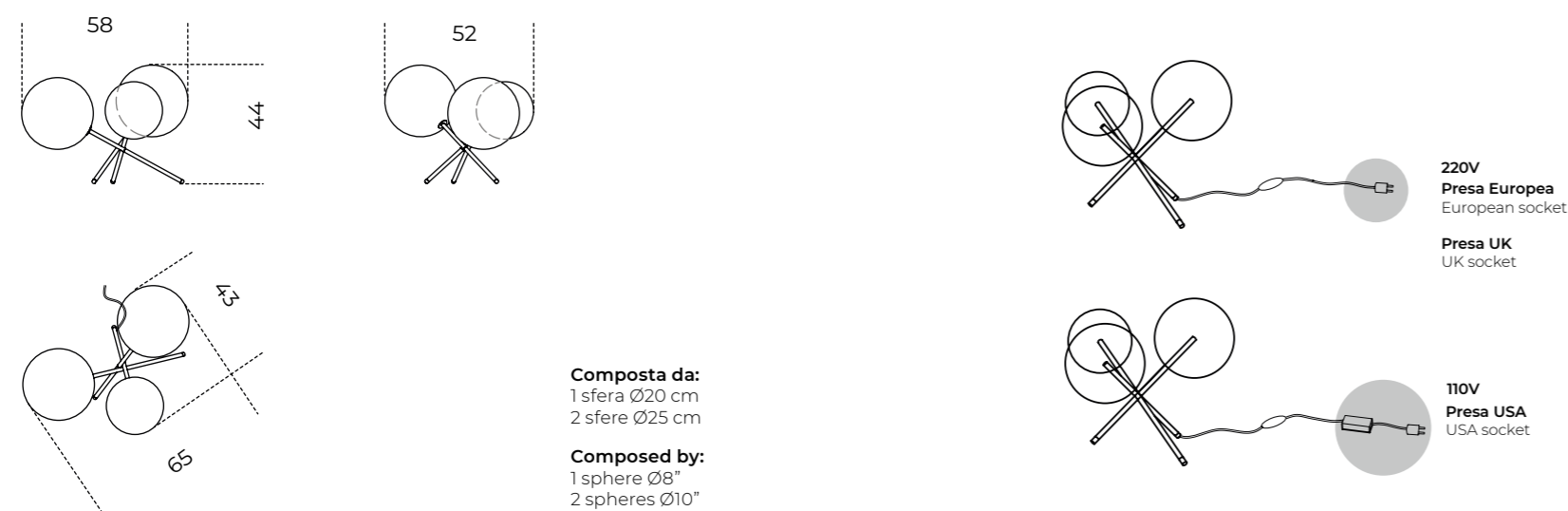
**Bolle Verticale** | Massimo Castagna, 2022

Product information / p. 574

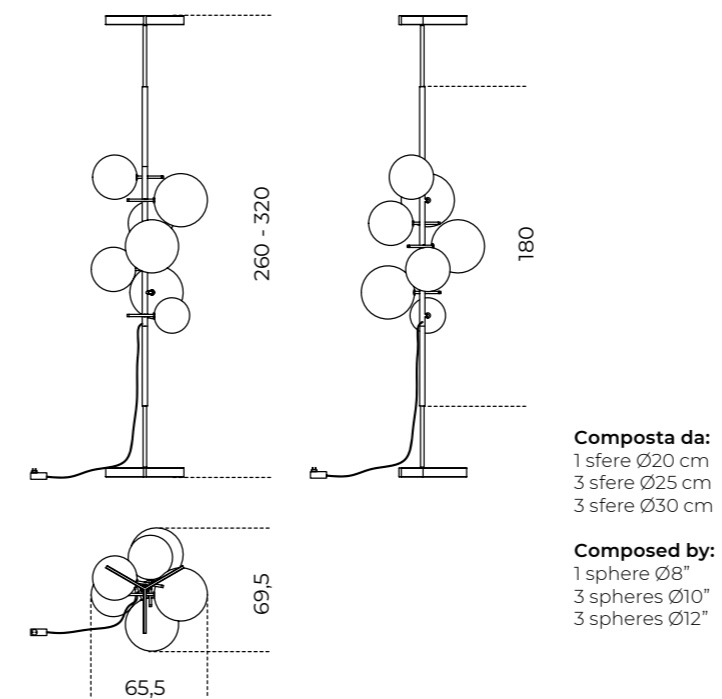

**Bonfire** | Studiopepe, 2020

Product information / p. 576

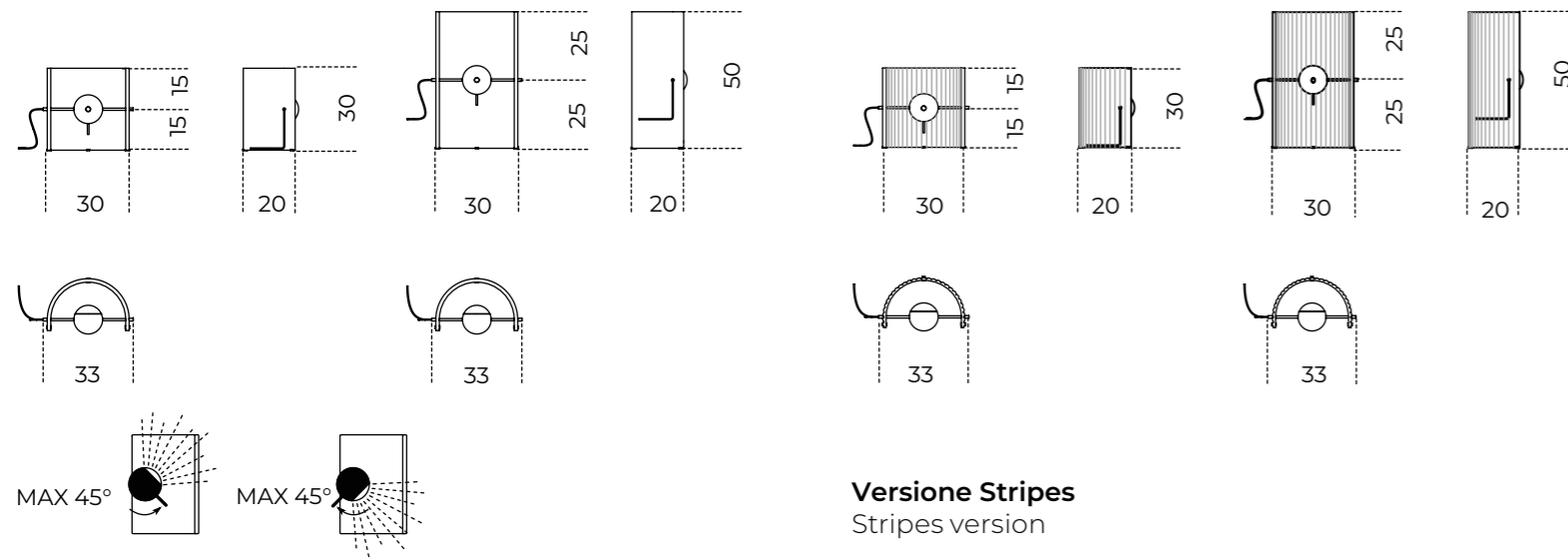

**Epsilon** | Massimo Castagna, 2016

Product information / p. 582

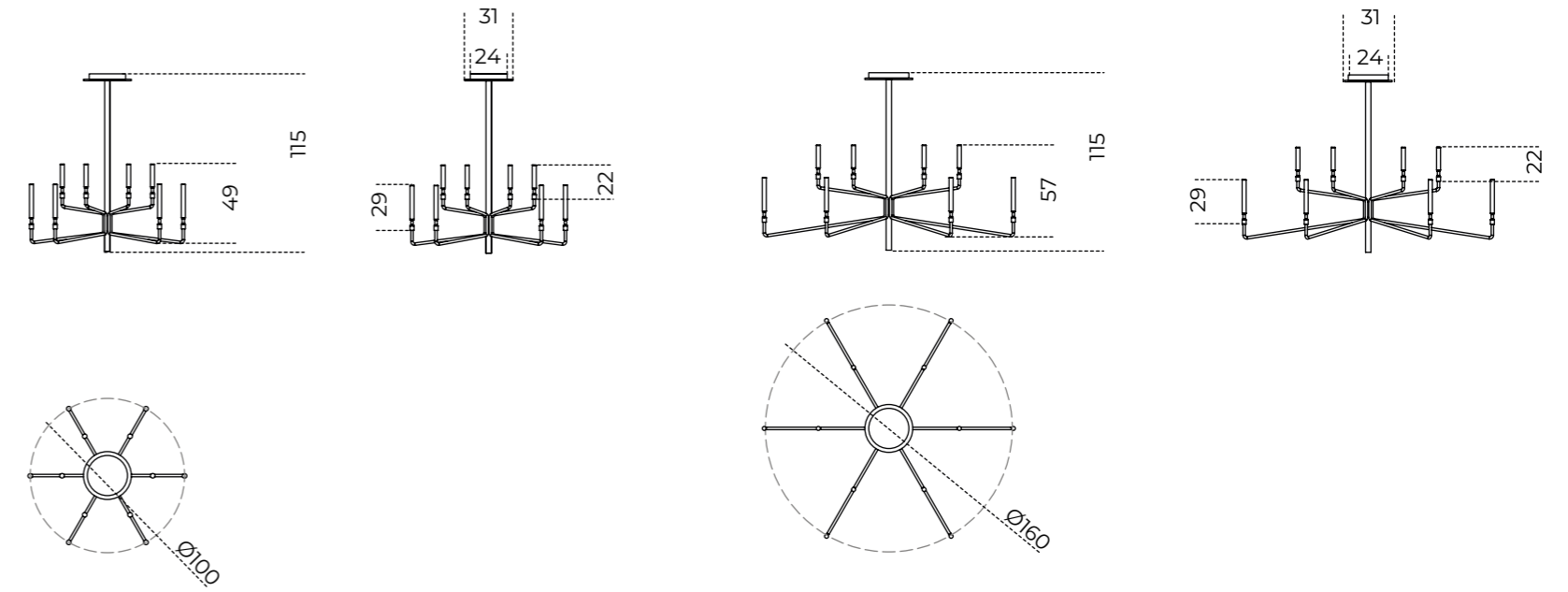

**Diantha** | Massimo Castagna, 2017

Product information / p. 578

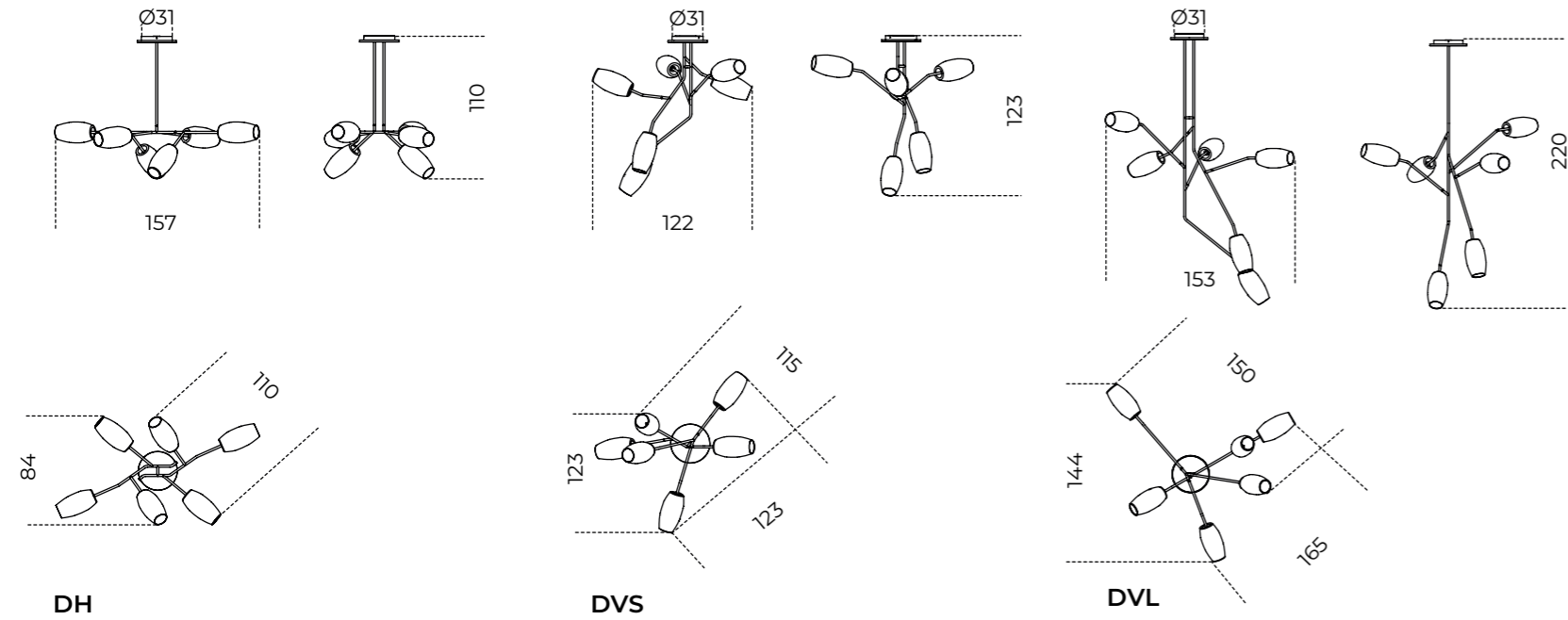

**Epsilon Sola** | Massimo Castagna, 2017

Product information / p. 584

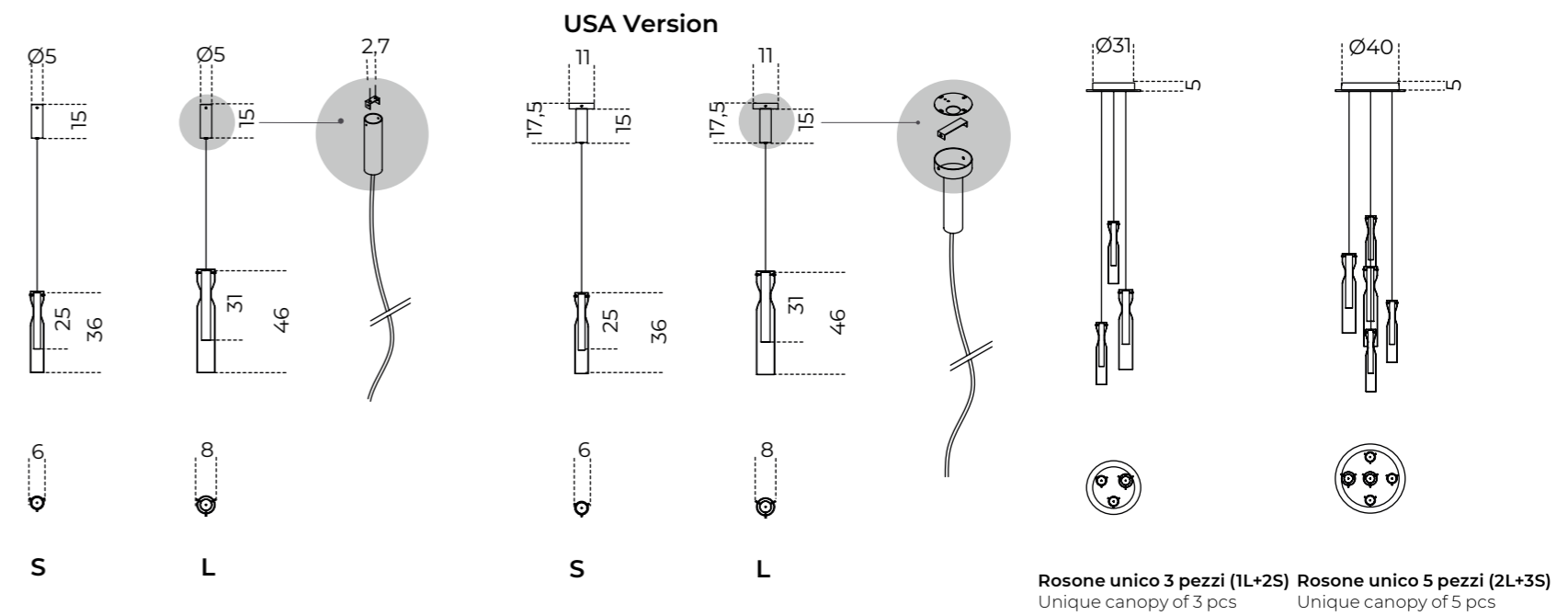

**Diantha Terra** | Massimo Castagna, 2018

Product information / p. 580

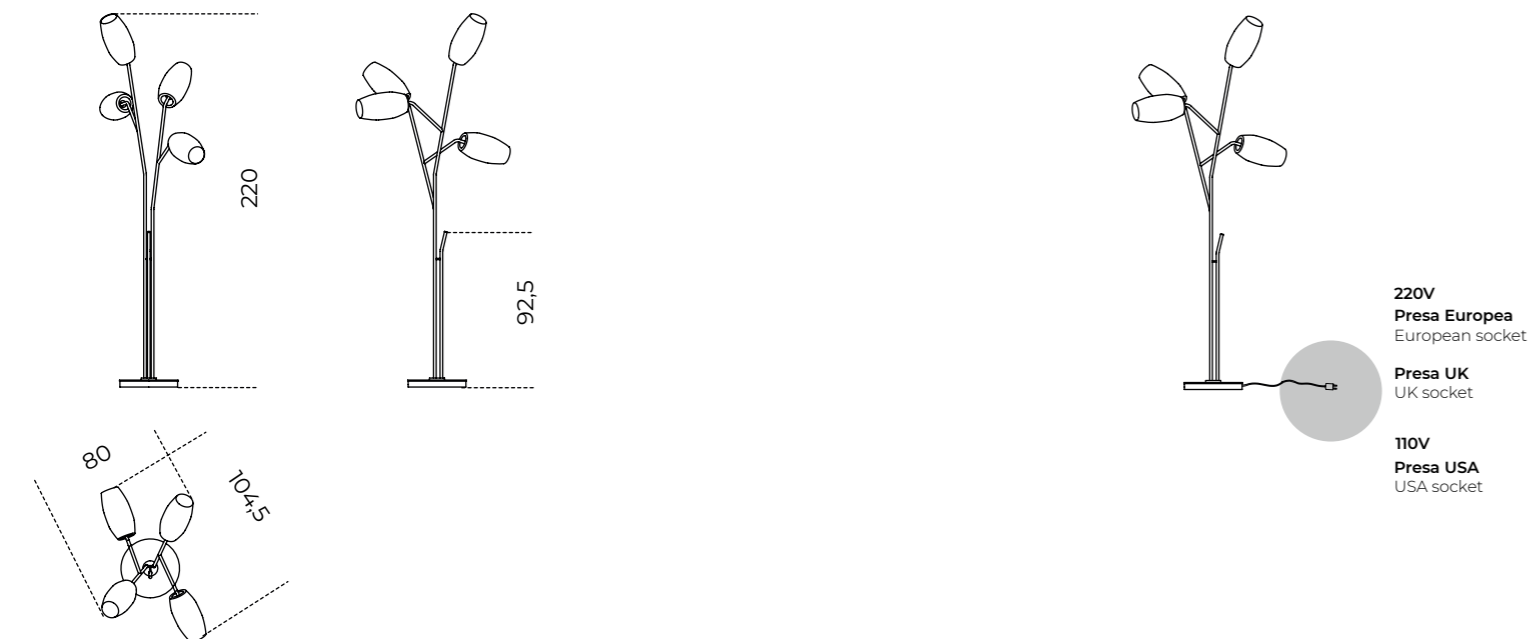

**Eris** | Massimo Castagna, 2017

Product information / p. 586

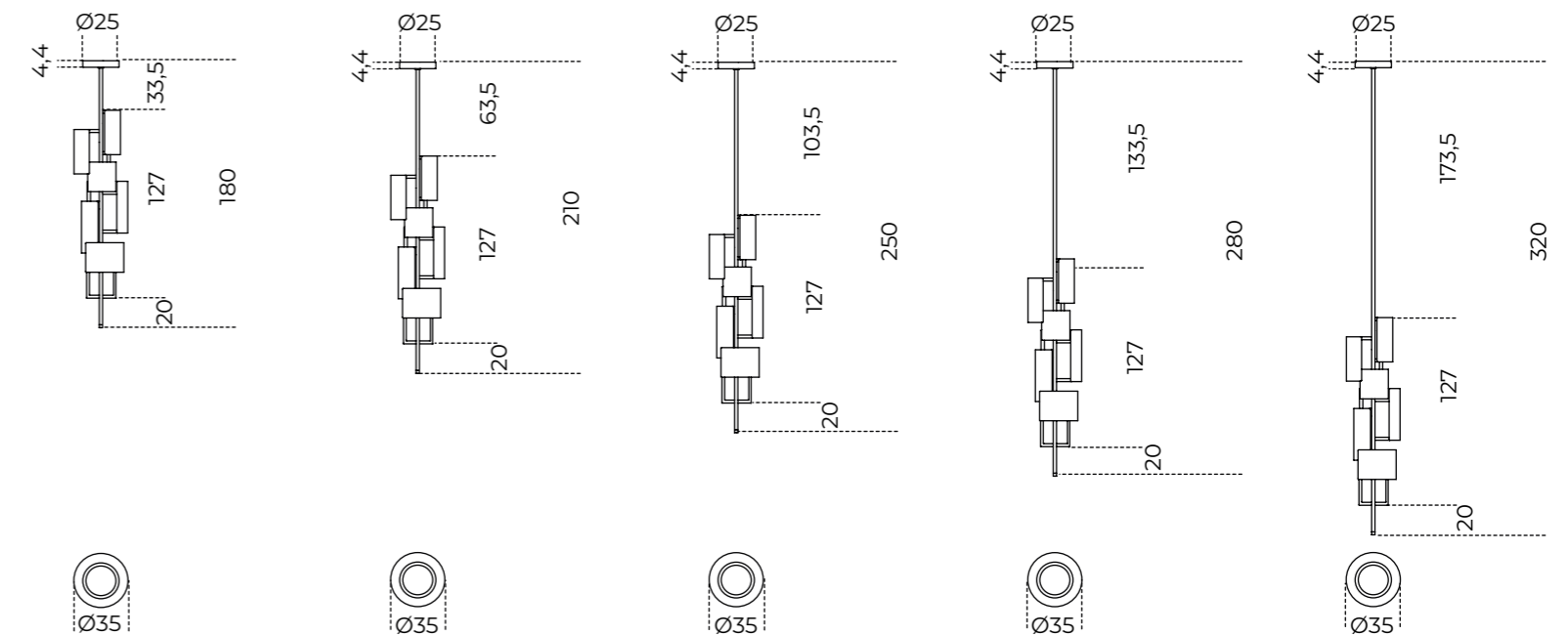

**Jolie** | Federica Biasi, 2019

[Product information / p. 588](#)

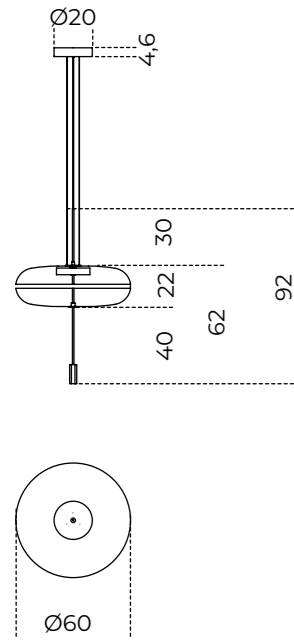

**Key-to-Heaven Fix** | Massimo Castagna, 2023

[Product information / p. 594](#)

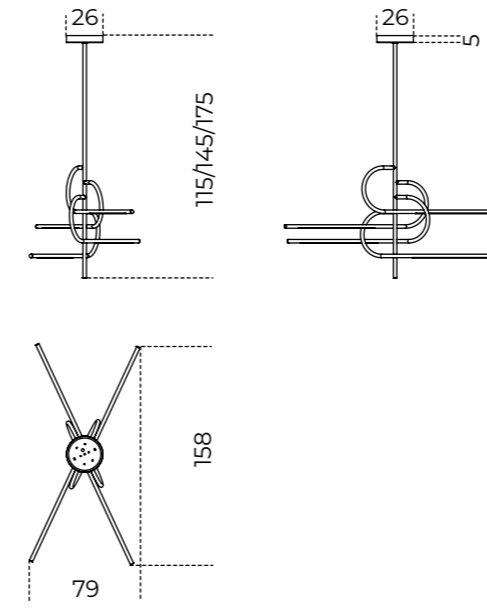

**Jolie Applique** | Federica Biasi, 2019

[Product information / p. 590](#)

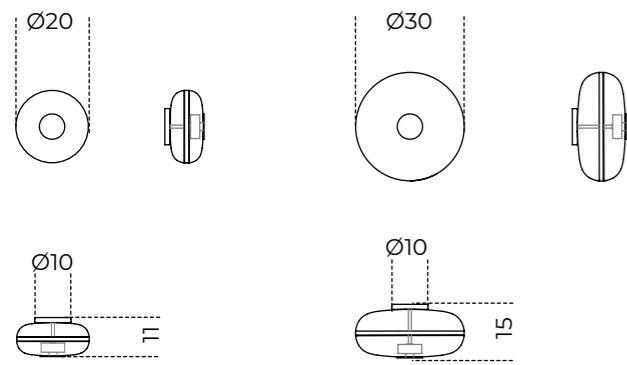

**Narghilè** | Massimo Castagna, 2018

[Product information / p. 596](#)

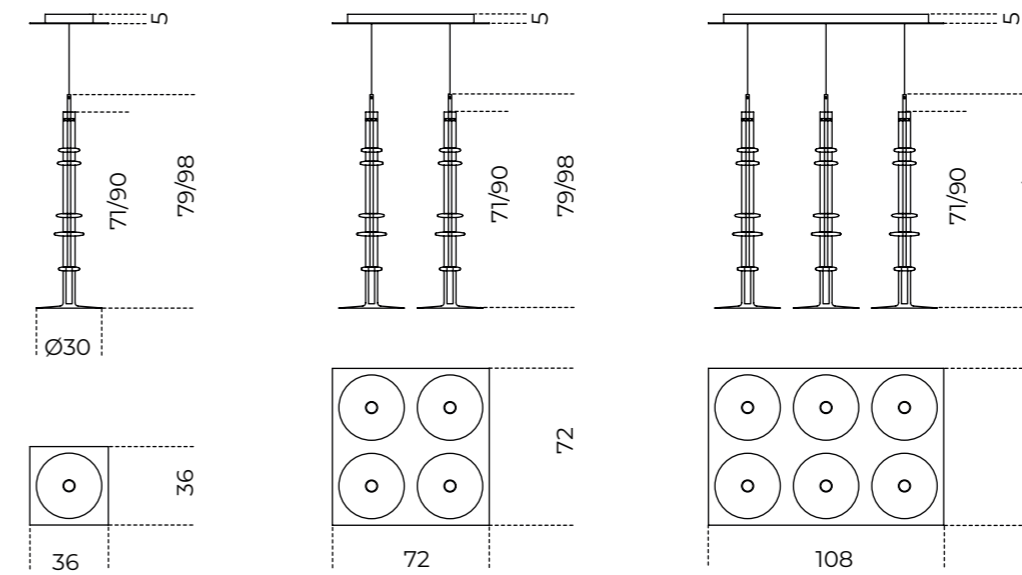

**Key-to-Heaven** | Massimo Castagna, 2022

[Product information / p. 592](#)

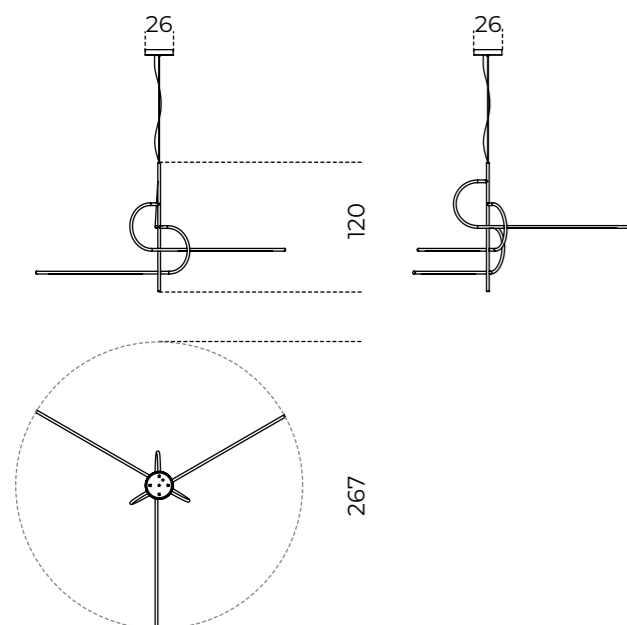

**Ori** | Massimo Castagna, 2017

[Product information / p. 598](#)

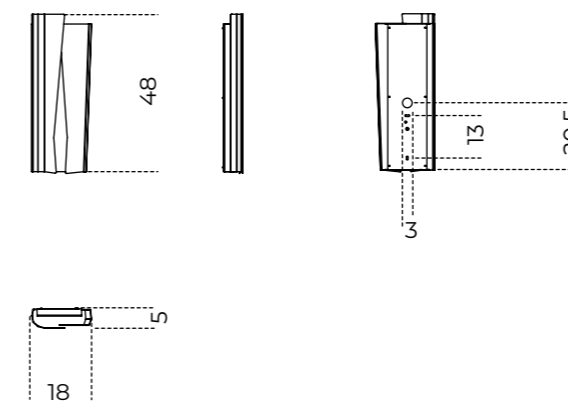

**Versione A**  
A version

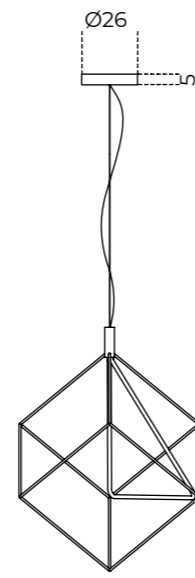
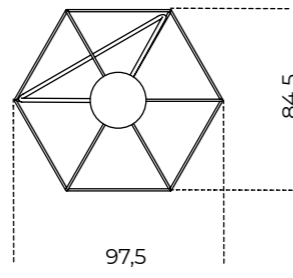
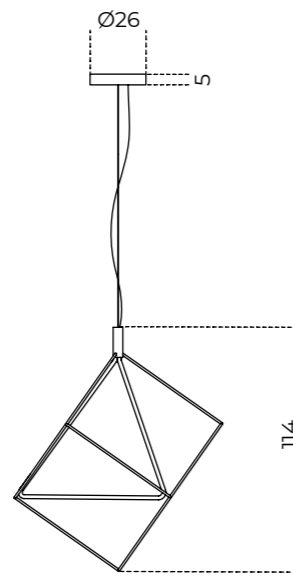
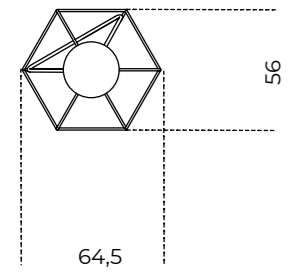
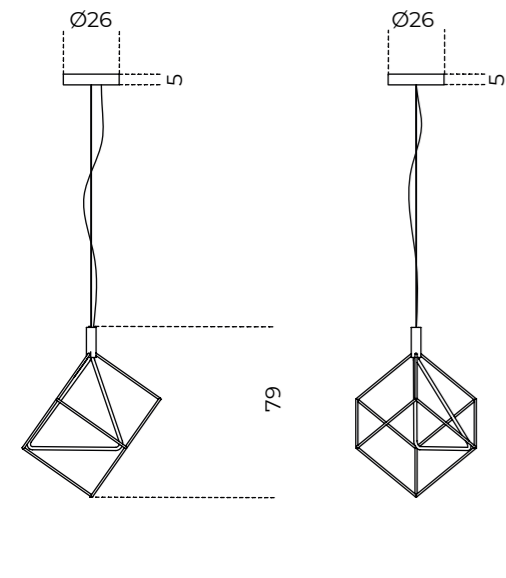

**Versione B**  
B version

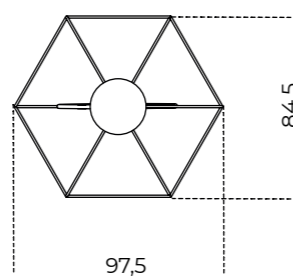
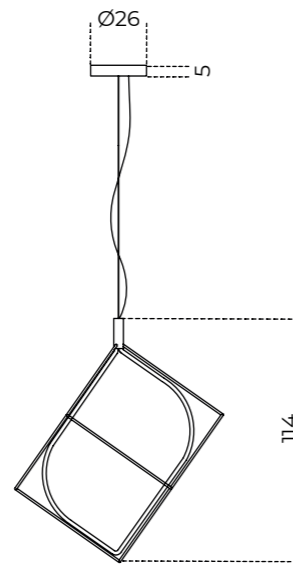
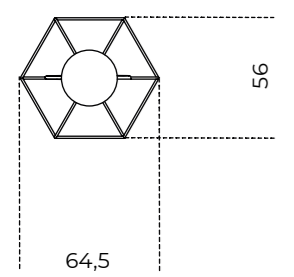
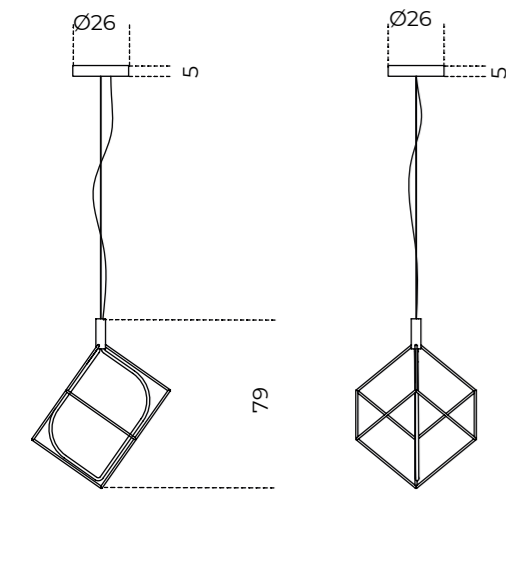

## **15** Specchi / Mirrors

- [618](#) **Black&White Beats**
- [620](#) **Cubista**
- [622](#) **Dream**
- [624](#) **Garda**
- [626](#) **Gemma**
- [628](#) **Keplero**
- [630](#) **Leaf**
- [632](#) **Lebel10**
- [634](#) **Niagara**
- [636](#) **Odette**
- [638](#) **Selene Mirror**
- [640](#) **Soft**
- [642](#) **Sole**
- [644](#) **Zed**
- [646](#) **Zeiss Mirror**
  
- [648](#) **Informazioni tecniche/  
Technical informations**

# Black&White Beat

Pietro Russo/2016

Specchio 6mm bisellato e lucidato a mano con inserti in cristallo 6mm retroverniciato nero brillante. Composto da 42 cristalli specchiati e retroverniciati nero brillante.

6mm bevelled and polished by hand mirror with 6mm bright black painted glass inserts. Made of 42 mirrored and bright black painted glass.

! La creazione di questo prodotto è completamente artigianale. I 42 cristalli vengono molati e lucidati a mano, ogni elemento viene poi posizionato singolarmente per mantenere le distanze e ottenere il disegno geometrico che caratterizza questo modello. Ogni specchio è frutto di un lavoro meticoloso e di cura per il dettaglio. Tempo, precisione ed esperienza sono essenziali per la realizzazione di questo prodotto e confermano il suo valore.

! The creation of this product is completely handmade. The 42 glass pieces are ground and polished by hand, each element is then positioned individually to keep the distance and obtain the geometric design that characterizes this model. Each mirror is the result of meticulous work and attention to detail. Time, precision and experience are essential for the realization of this product and confirm its value.

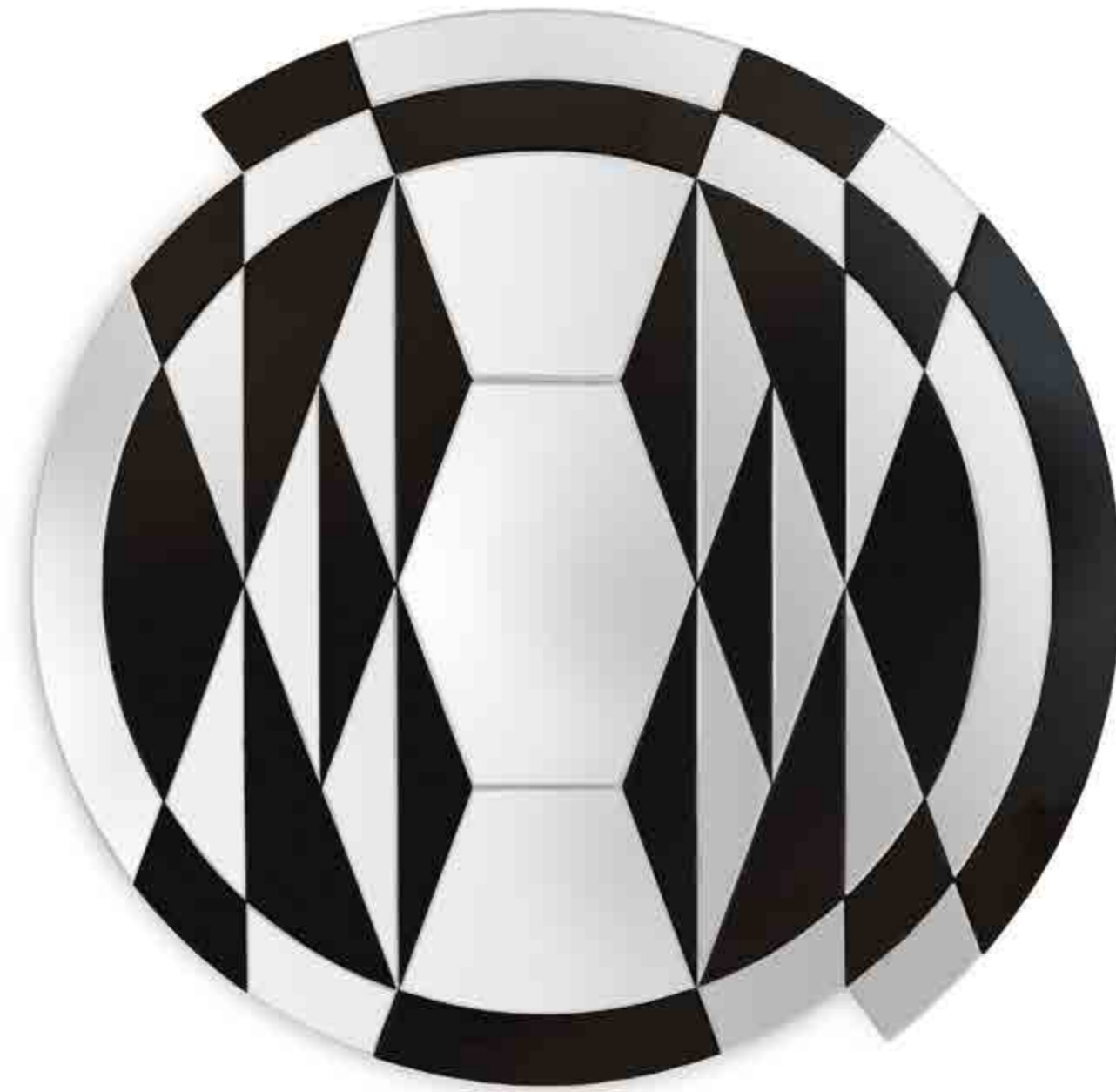

**Cm**  
142 x 142  
182 x 182

**Inches**  
56" x 56"  
71¼" x 71¼"

For technical drawing / p. 652

Pricelist 2023 / p. 206

## STRUTTURA/STRUCTURE



Specchio  
Mirror

## INSERTI/INSERTS

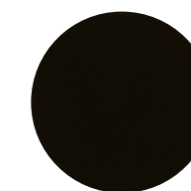

Cristallo retroverniciato  
nero brillante  
Bright black painted glass



# Cubista

Pietro Russo / 2018

Specchio 6mm bisellato e lucidato a mano con inserti in cristallo 6mm retroverniciato nero brillante. Composto da 17 cristalli specchiati e retroverniciati nero brillante.

! La creazione di questo prodotto è completamente artigianale. I 17 cristalli vengono molati e lucidati a mano, ogni elemento viene poi posizionato singolarmente per mantenere le distanze e ottenere il disegno geometrico che caratterizza questo modello. Ogni specchio è frutto di un lavoro meticoloso e di cura per il dettaglio. Tempo, precisione ed esperienza sono essenziali per la realizzazione di questo prodotto e confermano il suo valore.

6mm bevelled and polished by hand mirror with 6mm bright black painted glass inserts. Made of 17 mirrored and bright black painted glass.

! The creation of this product is completely handmade. The 17 glass pieces are ground and polished by hand, each element is then positioned individually to keep the distance and obtain the geometric design that characterizes this model. Each mirror is the result of meticulous work and attention to detail. Time, precision and experience are essential for the realization of this product and confirm its value.



Cm  
69,5 x 116

Inches  
27½" x 45¾"

For technical drawing / p. 650

Pricelist 2023 / p. 207

## STRUTTURA/STRUCTURE



Specchio  
Mirror

## INSERTI/INSERTS

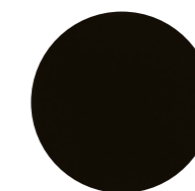

Cristallo retroverniciato  
nero brillante  
Bright black painted glass

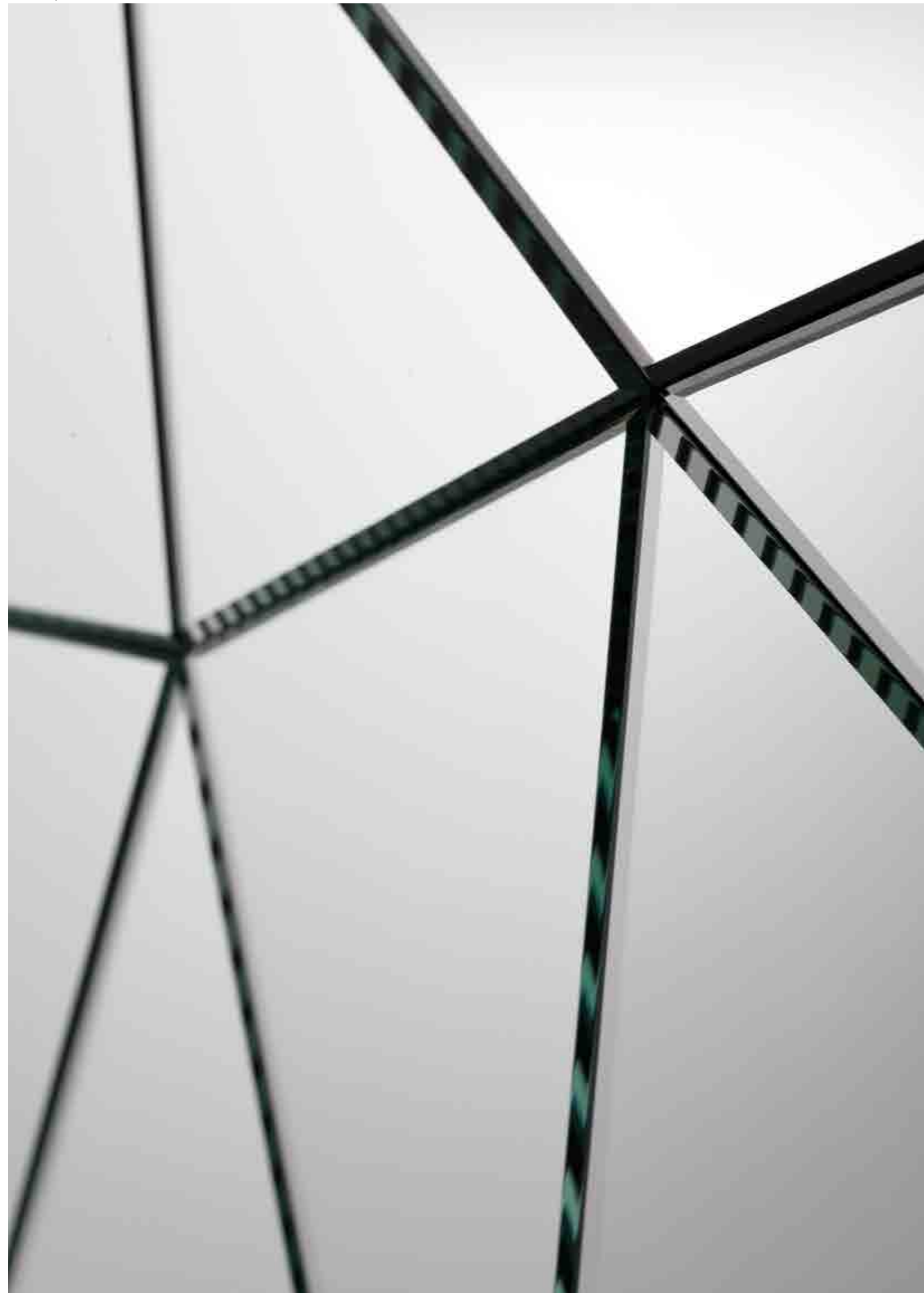

# Dream

Ricardo Bello Dias / 2007

Specchio 5mm molato a mano con parte centrale ottagonale e cornice composta da 40 specchi inclinati su piani diversi.

5mm hand polished mirror with octagonal central part and frame composed of 40 mirrors inclined on different levels.

! La creazione di questo prodotto è completamente artigianale. I 40 cristalli vengono molati e lucidati a mano, ogni elemento viene poi posizionato singolarmente per mantenere le distanze e ottenere il disegno geometrico che caratterizza questo modello. Ogni specchio è frutto di un lavoro meticoloso e di cura per il dettaglio. Tempo, precisione ed esperienza sono essenziali per la realizzazione di questo prodotto e confermano il suo valore.

! The creation of this product is completely handmade. The 40 glass pieces are ground and polished by hand, each element is then positioned individually to keep the distance and obtain the geometric design that characterizes this model. Each mirror is the result of meticulous work and attention to detail. Time, precision and experience are essential for the realization of this product and confirm its value.



**Cm**  
 Ø 120 x 6  
 Ø 150 x 6

**Inches**  
 47 1/4" x 2 1/2"  
 59 1/4" x 2 1/2"

For technical drawing / p. 650

Pricelist 2023 / p. 208

## STRUTTURA/STRUCTURE



Specchio  
 Mirror



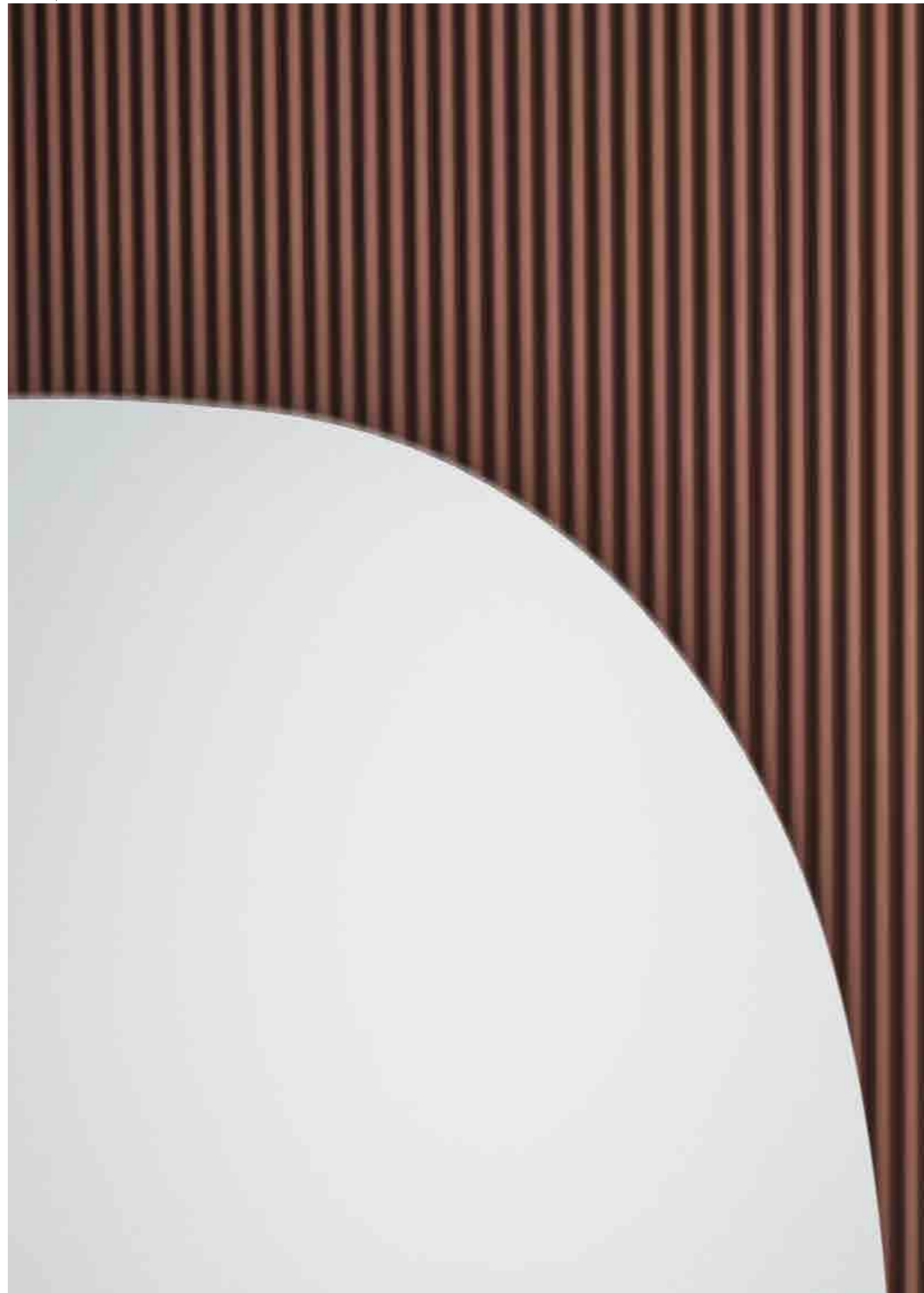

# Garda

Federica Biasi / 2022

Specchio con parte in legno fresato laccato opaco nei colori "terracotta" (RAL 8002), "seta" (RAL 7044) o "caffè nero" (RAL 8022). Su richiesta disponibile "Versione RAL" nel colore richiesto dal cliente.  
È possibile creare composizioni accostando più specchi anche con diversi orientamenti.

Mirror with milled wooden part, available matt lacquered in the colour "terracotta" (RAL 8002), "seta" (RAL 7044) or "caffè nero" (RAL 8022).  
"RAL Version" in the colour request by customer, on demand. It is possible to create compositions by combining several mirrors even with different orientations.



## Cm

A | 55 x 10 x 80  
B | 55 x 10 x 80  
C | 80 x 10 x 140  
D | 80 x 10 x 140

## Inches

21¾" x 4" x 31½"  
21¾" x 4" x 31½"  
31½" x 4" x 55¼"  
31½" x 4" x 55¼"

For technical drawing / p. 651

Pricelist 2023 / p. 209  
Homescapes, gentle attitude / pp. 90, 92, 93, 104

## PARTE IN LEGNO/ WOODEN PART



Terracotta



Seta

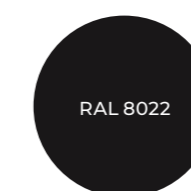

Caffè nero

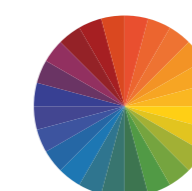

"Versione RAL"  
"RAL Version"



# Gemma

Studio G&R / 2013

Specchio extralight 6mm o "grigio Italia" 5mm con importante bisellatura da 25mm. 6mm extralight or 5mm smoked "grigio Italia" mirror with 25mm bevelled edge.



**Cm**  
 60 x 8 x 60  
 80 x 5 x 60  
 120 x 2 x 35

**Inches**  
 23¾" x 3¼" x 23¾"  
 31½" x 2" x 23¾"  
 47¼" x 1" x 14"

For technical drawing / p.651

Pricelist 2023 / p.210

## STRUTTURA/STRUCTURE



Specchio extralight  
Extralight mirror



Specchio "grigio Italia"  
Smoked "grigio Italia" mirror

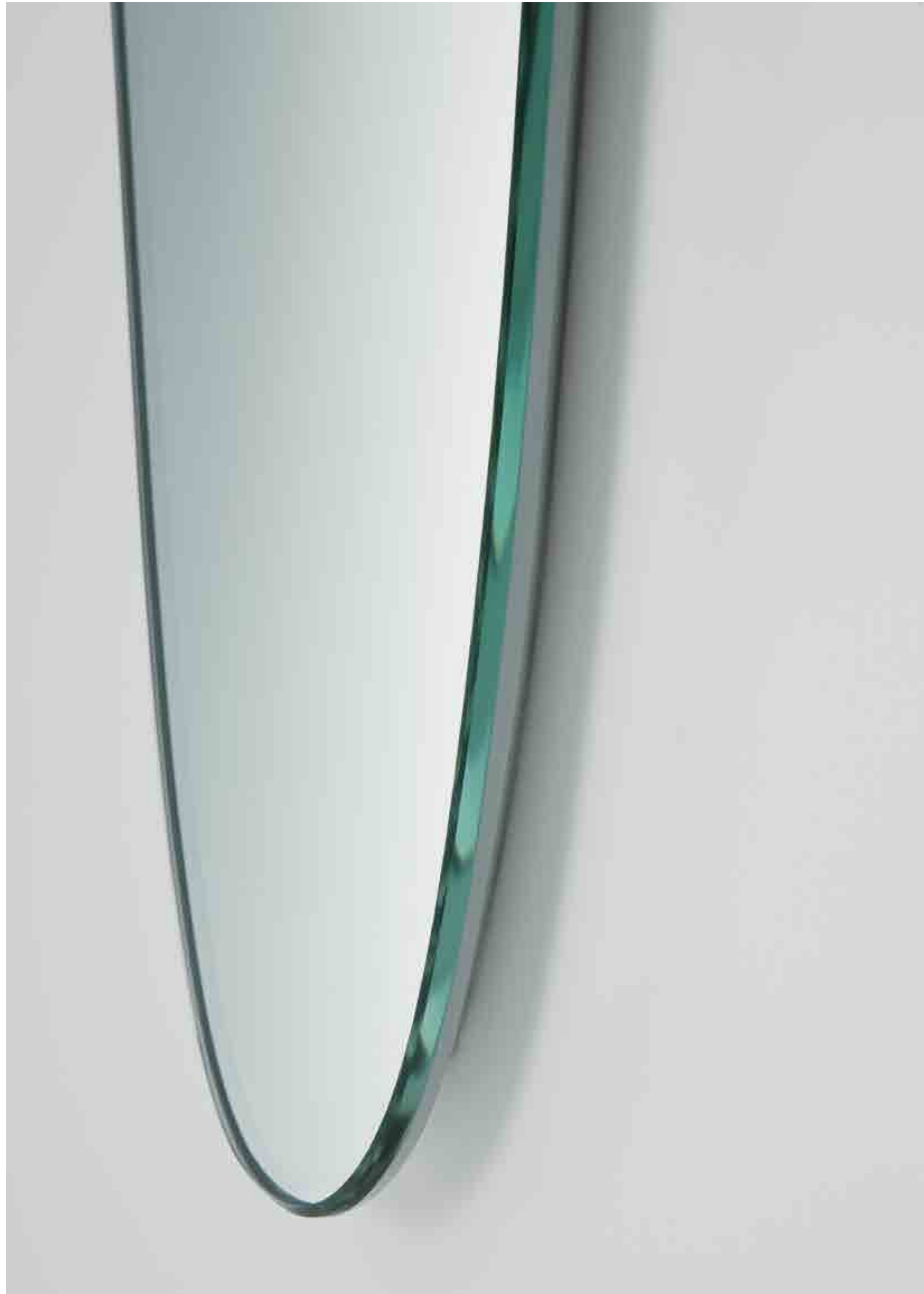

# Keplero

Andrea Bassoli/2002

Specchio 6mm molato a mano. Posizionabile sia in orizzontale che in verticale.

6mm hand polished mirror. It can be placed both in a horizontal or vertical position.



**Cm**  
26 x 200

**Inches**  
10¼" x 78¾"

[For technical drawing / p. 651](#)

[Pricelist 2023 / p. 211](#)

## STRUTTURA/STRUCTURE



**Specchio**  
Mirror

# Leaf

Ricardo Bello Dias / 2012

Sistema di specchi extralight 6mm o "grigio Italia" 5mm molati a bisello montati su pannelli a diverse inclinazioni. Disponibili in composizioni predefinite. Strutture di collegamento in metallo cromato o laccato color brunito.

System of 6mm extralight or 5mm smoked "grigio Italia" bevelled mirrors fixed on panels on different tilts. Available as per standard compositions. Chromed or burnished lacquered metal joint structure.

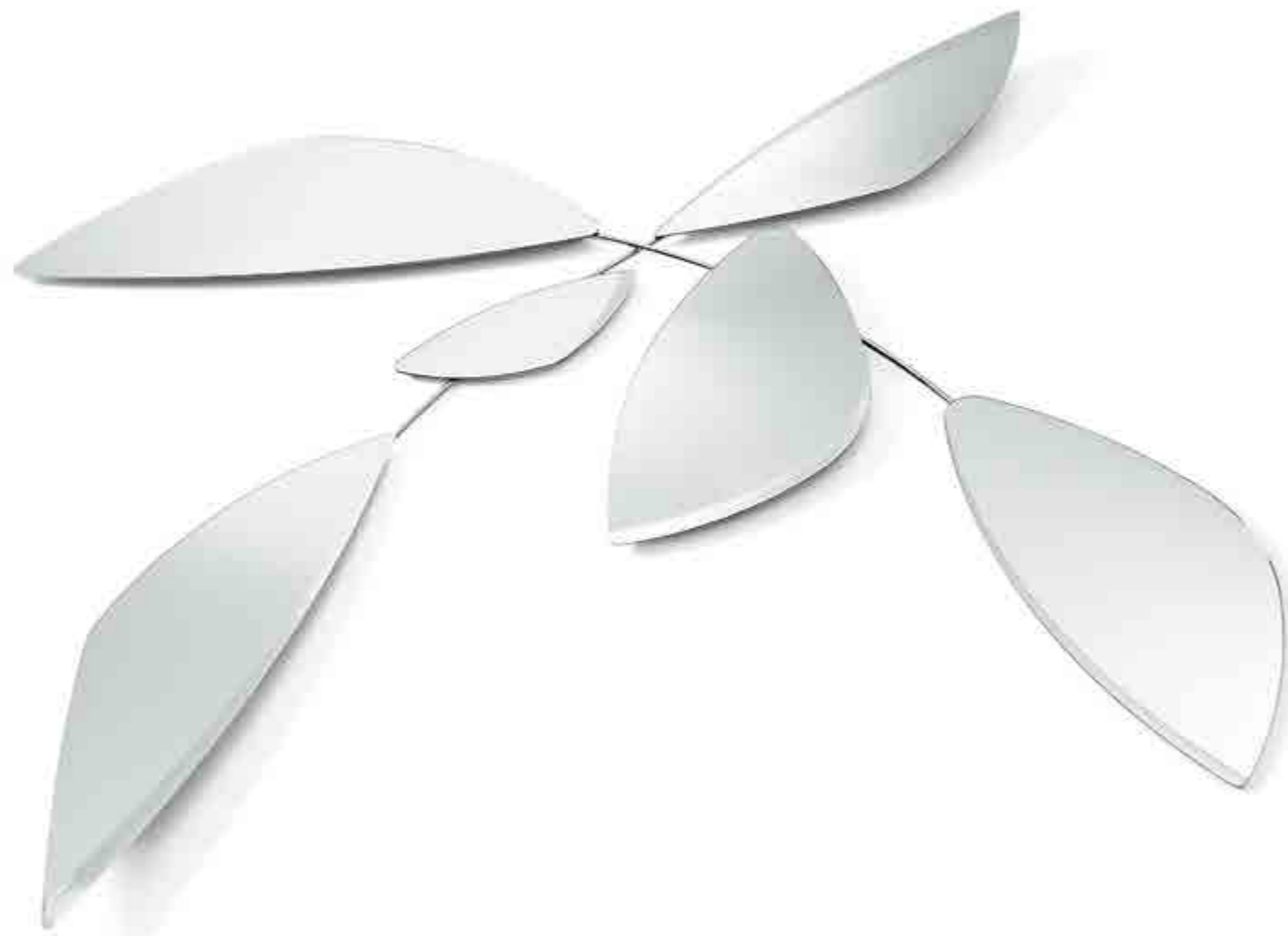

**Cm**  
Composizione 1  
215 x 200

**Composizione 2**  
180 x 235

**Inches**  
Composition 1  
84¾" x 78¾"

**Composition 2**  
71" x 92¾"

For technical drawing / p. 652

Pricelist 2023 / p. 212

## SPECCHI/MIRRORS



**Specchio extralight**  
Extralight mirror



**Specchio "grigio Italia"**  
Smoked "grigio Italia" mirror

## STRUTTURA/STRUCTURE



**Metallo cromato**  
Chromed metal

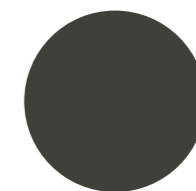

**Metallo laccato color brunito**  
Burnished lacquered metal



# Level 10

Studio G&R / 2010

Specchio 6mm composto da due specchi sovrapposti molati. Specchio superiore con importante bisellatura da 35mm.

6mm mirror made of two superimposed bevelled mirrors. Upper mirror with bevelled edge 35mm.



**Cm**  
 Ø 100  
 Ø 120  
 Ø 140

100 x 100  
 120 x 120  
 140 x 140  
 50 x 200  
 80 x 200

**Inches**  
 Ø 39½"  
 Ø 47¼"  
 Ø 55¼"

39½" x 39½"  
 47¼" x 47¼"  
 55¼" x 55¼"  
 19¾" x 78¾"  
 31½" x 78¾"

For technical drawing / p. 652

Pricelist 2023 / p. 213

## STRUTTURA/STRUCTURE



Specchio  
 Mirror

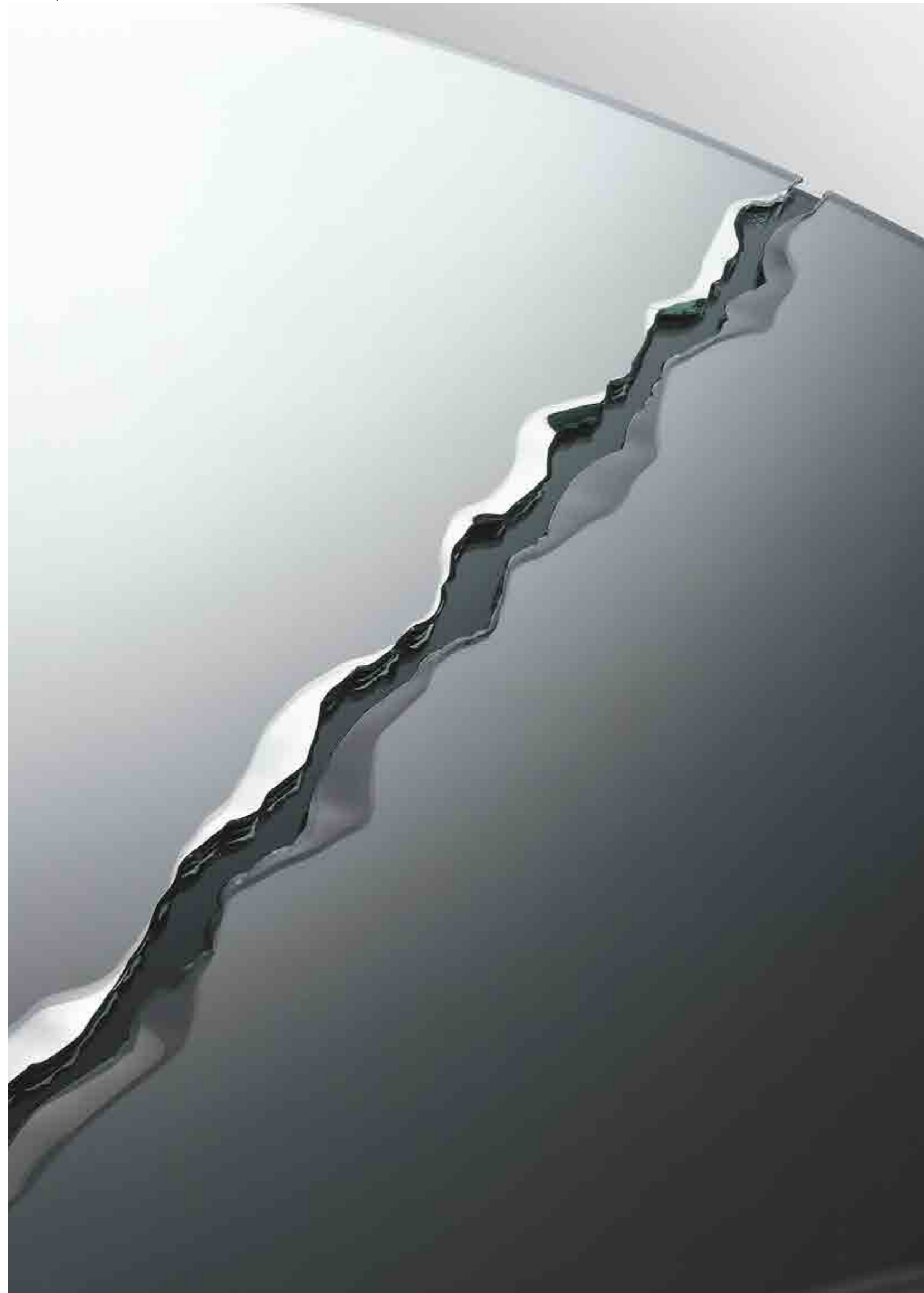

# Niagara

Pierangelo Gallotti / 1987

Specchio 6mm composto da due specchi molati, accostati e sovrapposti ad una parte in cristallo specchiato "grigio Italia". Specchi superiori con importante bisellatura centrale irregolare eseguita a mano.

! La creazione di questo prodotto è completamente artigianale. I due semicerchi vengono pinzati a mano per conferire l'irregolarità della spaccatura centrale, successivamente molati e lucidati a mano. La particolarità di questa lavorazione rende ogni prodotto unico e non replicabile. Ogni specchio è frutto di un lavoro meticoloso e di cura per il dettaglio. Tempo, precisione ed esperienza sono essenziali per la realizzazione di questo prodotto e confermano il suo valore.

6mm mirror composed of two bevelled mirrors placed side by side and superimposed on a smoked "grigio Italia" mirrored part. Upper mirrors with important irregular central bevel done by hand.

! The creation of this product is completely handmade. The two semicircles are clamped by hand to give the irregularity of the central part, then ground and polished by hand. The particularity of this workmanship makes each product unique and non-replicable. Each mirror is the result of meticulous work and attention to detail. Time, precision and experience are essential for the realization of this product and confirm its value.



Cm	Inches
Ø 80	Ø 31½"
Ø 100	Ø 39½"
Ø 120	Ø 47¼"
80 x 80	31½" x 31½"
100 x 100	39½" x 39½"

For technical drawing / p. 653

Pricelist 2023 / p. 214

## STRUTTURA/STRUCTURE



Specchio  
Mirror



▲ ODETTE  
Specchio "Antique 2" / Dettaglio in ottone lucido  
"Antique 2" mirror / bright brass detail

# Odette

Studio G&R / 2015

Specchio extralight 6mm con particolare decorativo in ottone lucido posizionabile a discrezione lungo il perimetro. Disponibile anche in specchio 5mm "Antique 1" o "Antique 2".

6mm extralight mirror with bright brass decorative detail, which can be placed around the perimeter, according to the customer choice. Also available in 5mm "Antique 1" or "Antique 2" mirror.



**Cm**  
Ø 50  
Ø 80

58 x 36  
76 x 47  
60 x 60  
80 x 80  
30 x 140

**Inches**  
Ø 19¾"  
Ø 31½"

23" x 14¼"  
30" x 18¾"  
23¾" x 23¾"  
31½" x 31½"  
12" x 55¼"

For technical drawing / p. 653

Pricelist 2023 / p. 215

## SPECCHIO/MIRROR



Specchio extralight  
Extralight mirror



Specchio "Antique 1"  
"Antique 1" mirror



Specchio "Antique 2"  
"Antique 2" mirror

## DETTAGLIO/DETAILS



Ottone lucido  
Bright brass



# Selene Mirror

Pietro Russo / 2016

Specchio vanity da tavolo dotato di luce LED. Specchio extralight 6mm con bisello 20mm. Parti metalliche laccate ottone satinato e base in marmo levigato opaco Nero Marquinia.

Vanity mirror with LED light. 6mm extralight mirror with bevel 20mm. Satin brass lacquered metal parts and honed mat Nero Marquinia marble base.



**Cm**  
Ø40 x 12 x 65

**Inches**  
Ø15¾" x 4¾" x 25¾"

For technical drawing / p. 653

Pricelist 2023 / p. 216

## SPECCHIO/MIRROR



Specchio extraligh  
Extralight mirror

## PARTI METALLICHE/ METAL PARTS



Laccato ottone satinato  
Satin brass lacquered

## BASE/BASE



Marmo levigato opaco  
Nero Marquinia  
Honed mat Nero Marquinia  
marble

## LUCE/LIGHT

LED  
15 Watt  
108 lm  
3000°K



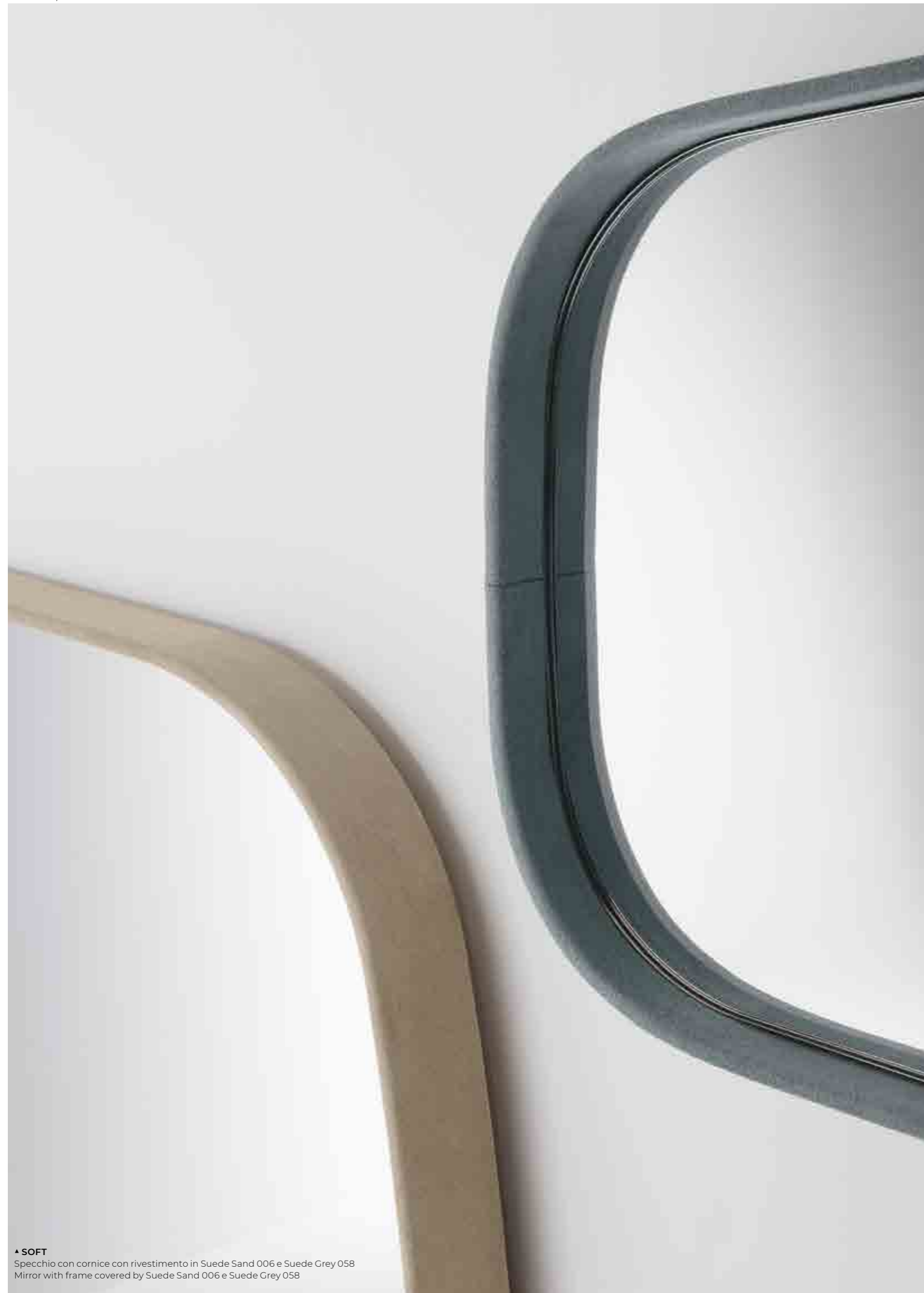

▲ **SOFT**  
Specchio con cornice con rivestimento in Suede Sand 006 e Suede Grey 058  
Mirror with frame covered by Suede Sand 006 e Suede Grey 058

# Soft

Studio G&R / 2014

Specchio 6mm con cornice (profondità 5cm) rivestita in pelle scamosciata nei colori del campionario.

6mm mirror with frame (thickness 5cm) covered by suede as per samples.

! Non realizzabile su misura.

! Not available in custom size.



**Cm**  
80 x 80  
115 x 150  
40 x 180

**Inches**  
31½" x 31½"  
45½" x 59¼"  
15¾" x 71"

[For technical drawing / p. 654](#)

[Pricelist 2023 / p. 217](#)

## STRUTTURA/STRUCTURE



Specchio  
Mirror

## CORNICE/FRAME

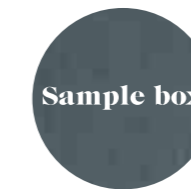

Pelle scamosciata nei colori del campionario  
Suede as per samples

# Sole

Studio G&R/1975

Specchio 6mm composto da due specchi sovrapposti. Specchio centrale con bisellatura da 30mm.

6mm mirror made of two superimposed mirrors. Central mirror with 30mm bevelled edge.



**Cm**  
Ø 150  
Ø 165

**Inches**  
Ø 59¼"  
Ø 65"

[For technical drawing / p. 654](#)

[Pricelist 2023 / p. 218](#)  
[Homescapes, gentle attitude / p. 84](#)

## STRUTTURA/STRUCTURE



**Specchio**  
Mirror



# Zed

Ricardo Bello Dias / 2006

Specchio 6mm con struttura autoportante in metallo piegato e verniciato color grigio umbro.

6mm mirror with freestanding dark grey lacquered bent metal structure.

**Cm**  
30 x 39 x 175

**Inches**  
12" x 15½" x 69"

[For technical drawing / p.654](#)

[Pricelist 2023 / p.219](#)

## SPECCHIO/MIRROR



**Specchio**  
Mirror

## STRUTTURA/STRUCTURE

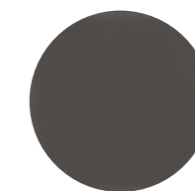

**Metallo verniciato  
grigio umbro**  
Dark grey lacquered metal



# Zeiss Mirror

Luca Nichetto / 2009

Specchio extralight 6mm molato e bisellato a mano, in tre diverse forme e dimensioni. Cornice in legno (spessore 5cm) laccato bianco oppure effetto "tessuto" nei colori castagna, sabbia e canapa.

6mm hand polished and bevelled extralight mirror in three different shapes and sizes. White lacquered wooden frame (thickness 5cm) or lacquered with "fabric" touch effect in the colours chestnut, sand and canapa.



	Cm	Inches
S	80 x 6 x 78	31½" x 2½" x 30¾"
M	104 x 6 x 92	41" x 2½" x 36¼"
L	156 x 6 x 151	61½" x 2½" x 59½"

[For technical drawing / p. 655](#)

[Pricelist 2023 / p. 220](#)  
[Homescapes, sense of materials / p. 108](#)  
[Homescapes, gentle attitude / pp. 54, 55](#)

## SPECCHIO/MIRROR



Specchio extralight  
Extralight mirror

## CORNICE/FRAME



Legno laccato bianco  
White lacquered wood

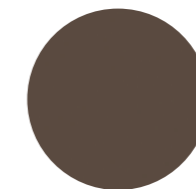

Legno laccato effetto  
"tessuto" color castagna  
Chestnut with "fabric"  
touch effect lacquered



Legno laccato effetto  
"tessuto" color sabbia  
Sand with "fabric"  
touch effect lacquered



Legno laccato effetto  
"tessuto" color canapa  
Canapa with "fabric"  
touch effect wood

# 15

**Specchi / Mirrors**  
**TECHNICAL MODULE**

**Black&White Beat** | Pietro Russo, 2016

Product information / p. 618

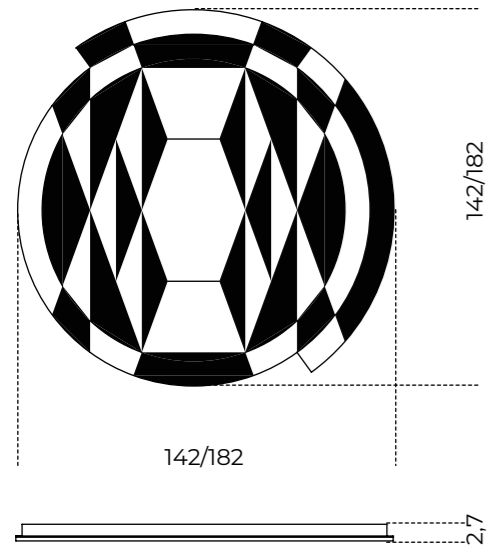

**Cubista** | Pietro Russo, 2018

Product information / p. 620

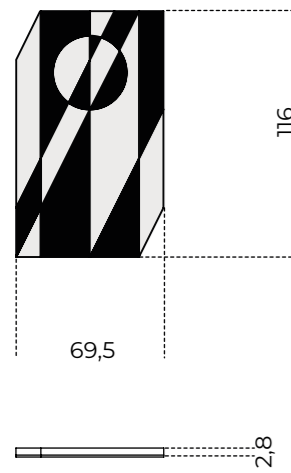

**Dream** | Ricardo Bello Dias, 2007

Product information / p. 622

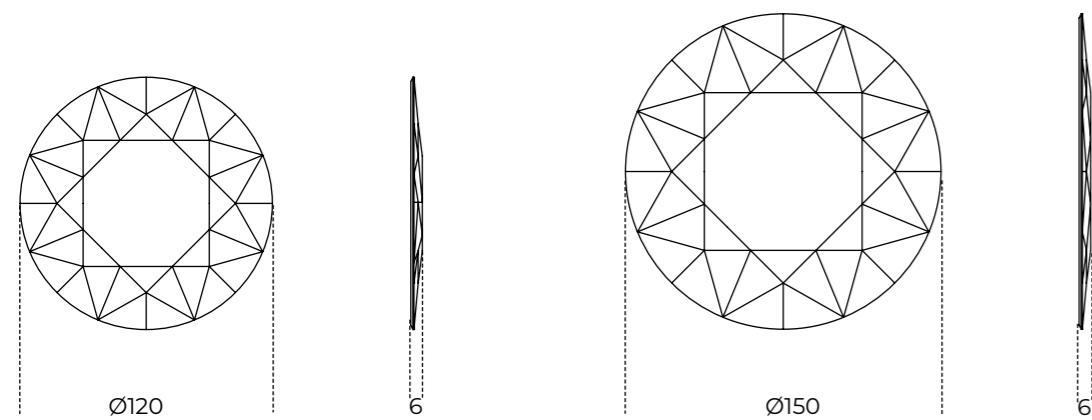

**Garda** | Federica Biasi, 2022

Product information / p. 624

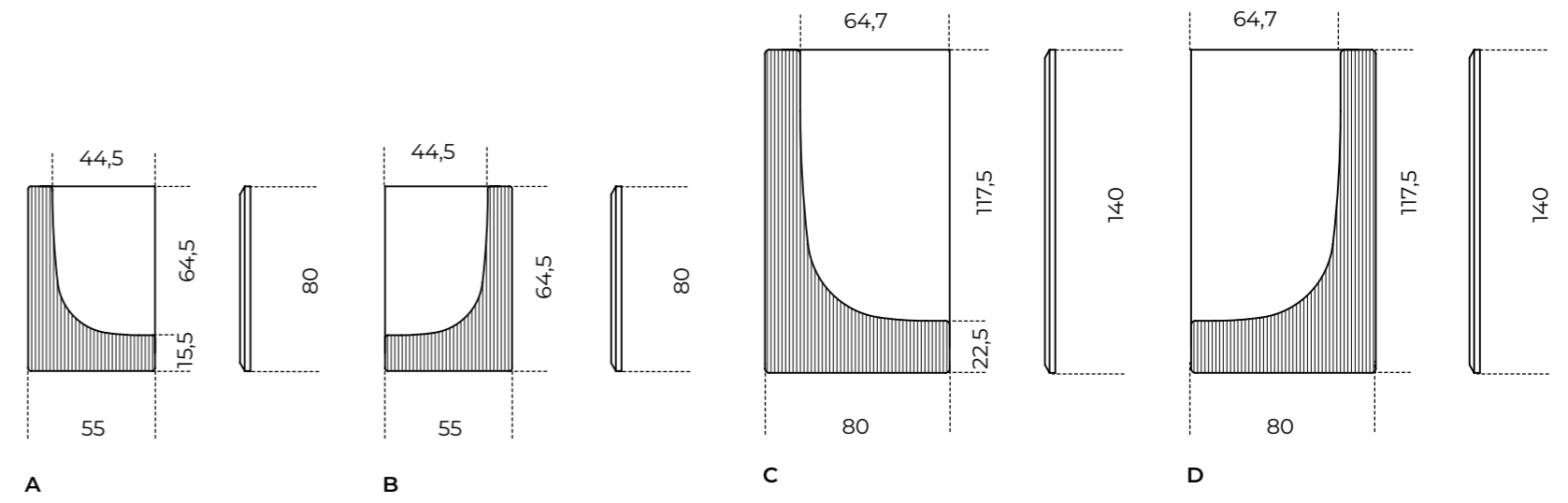

**Gemma** | Studio G&R, 2013

Product information / p. 626

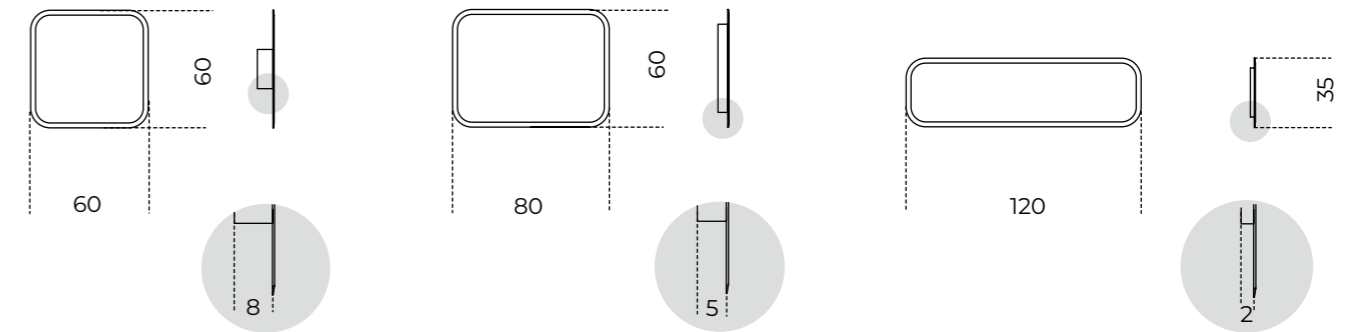

**Keplero** | Andrea Bassoli, 2002

Product information / p. 628

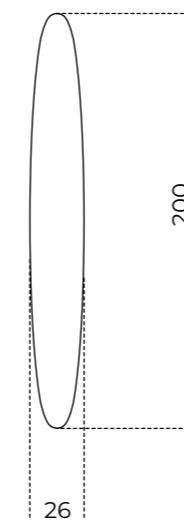

**Leaf** | Ricardo Bello Dias, 2012

Product information / p. 630

**Composizione 1**  
Composition 1

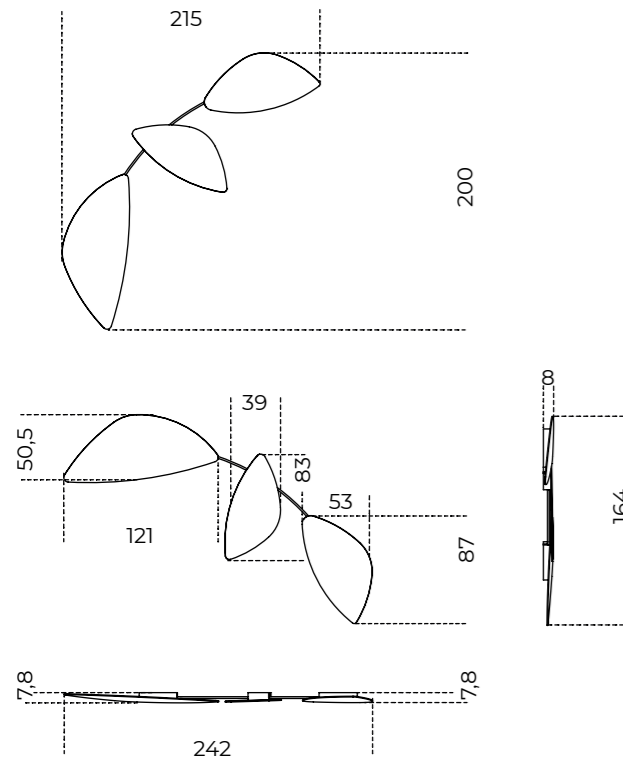

**Composizione 2**  
Composition 2

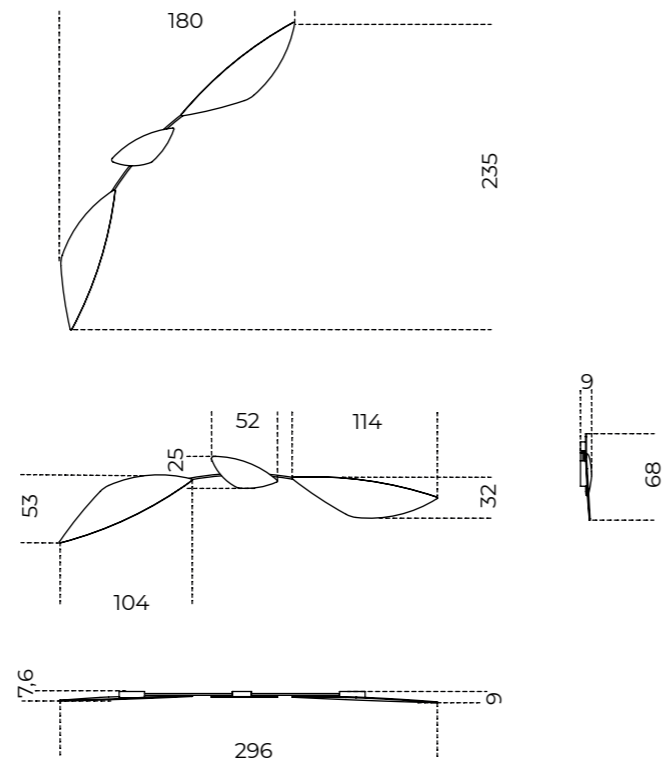

**Combinazione 1** / Combination 1

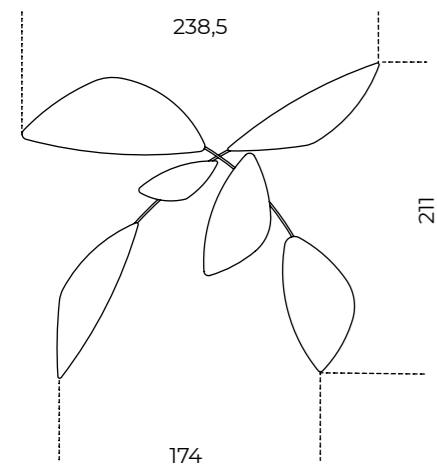

**Combinazione 2** / Combination 2

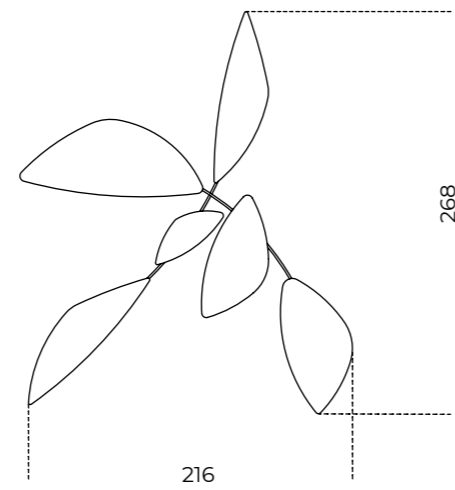

**Lebel10** | Studio G&R, 2010

Product information / p. 632

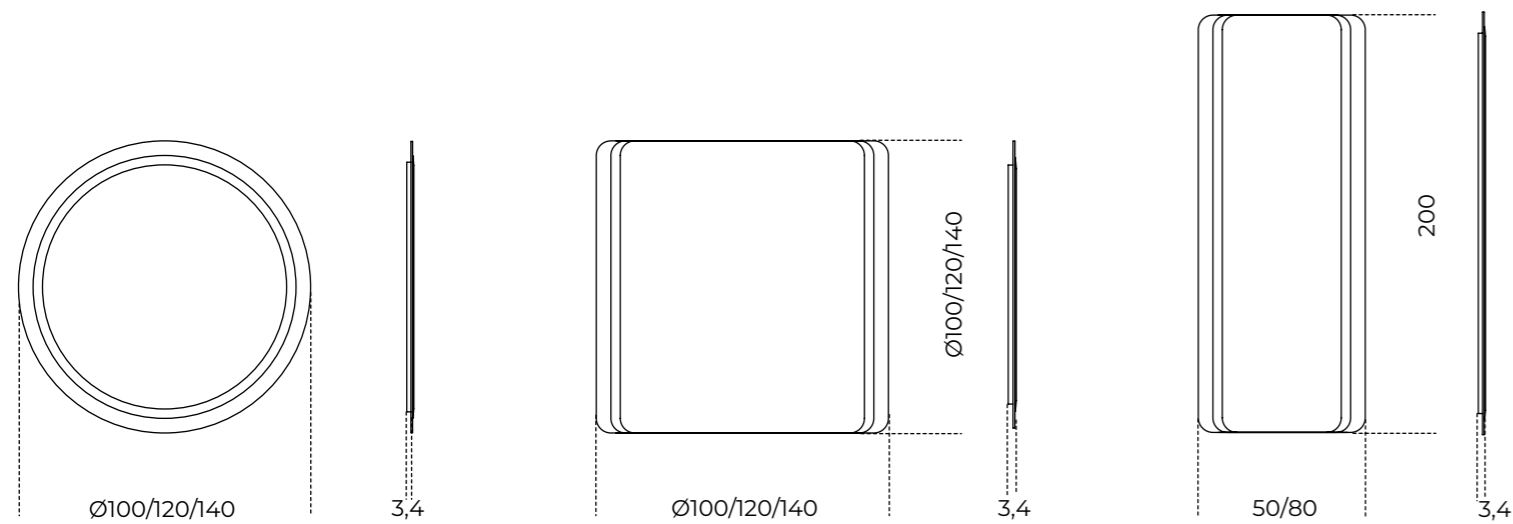

**Niagara** | Pierangelo Gallotti, 1987

Product information / p. 634

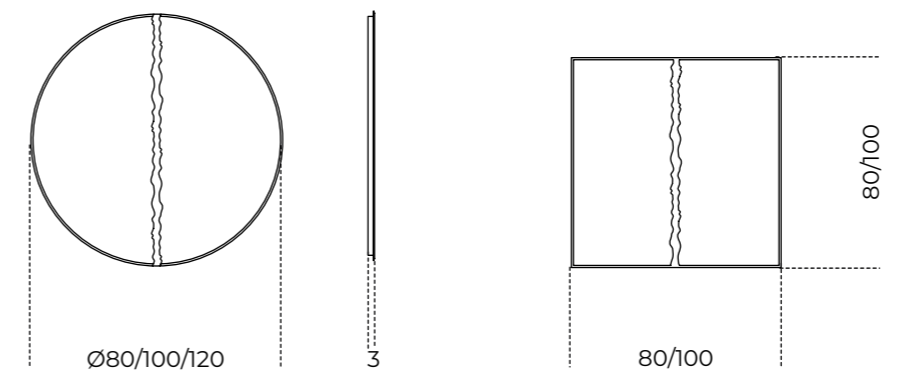

**Odette** | Studio G&R, 2015

Product information / p. 636

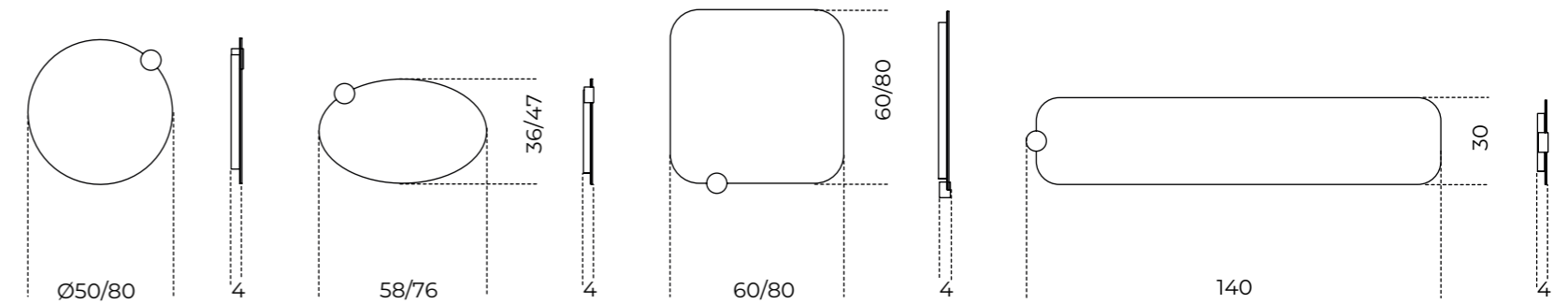

**Selene Mirror** | Pietro Russo, 2016

Product information / p. 638

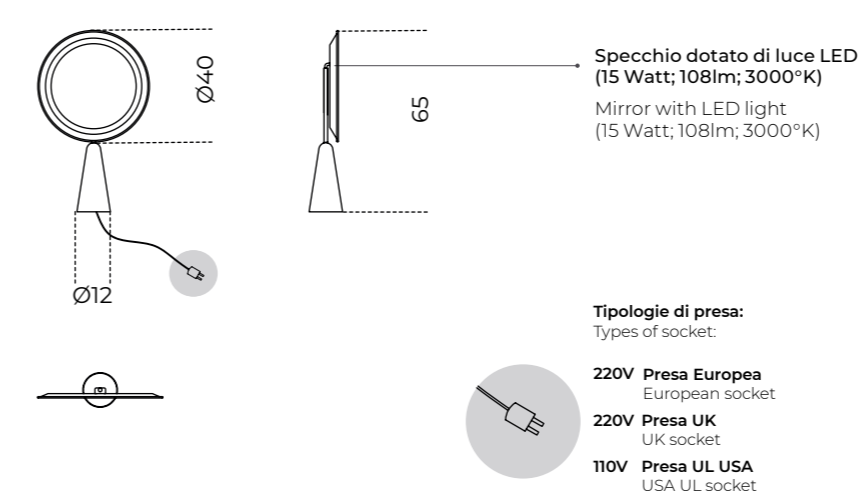

Soft | Studio G&R, 2014

Product information / p. 640

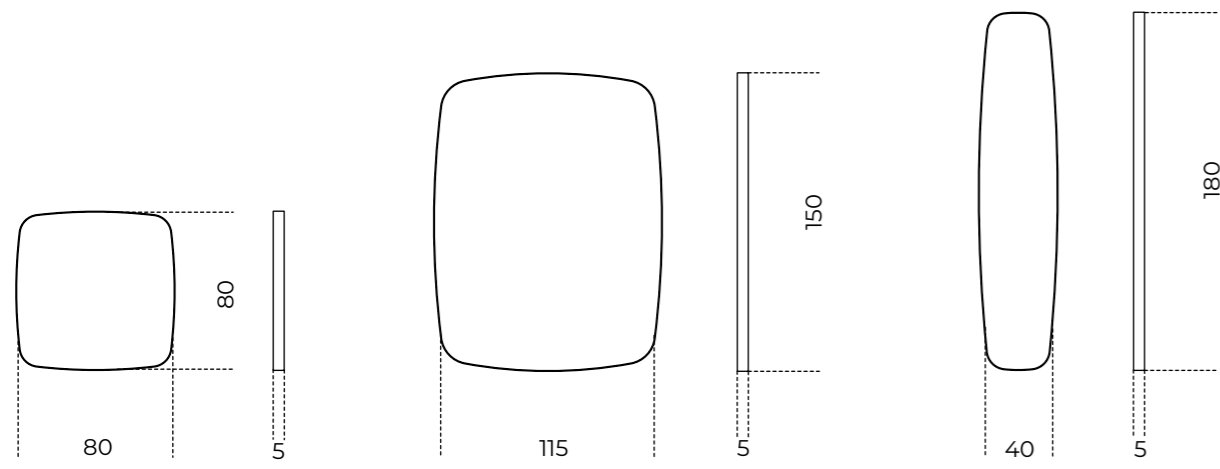

Zeiss Mirror | Luca Nichetto, 2009

Product information / p. 646

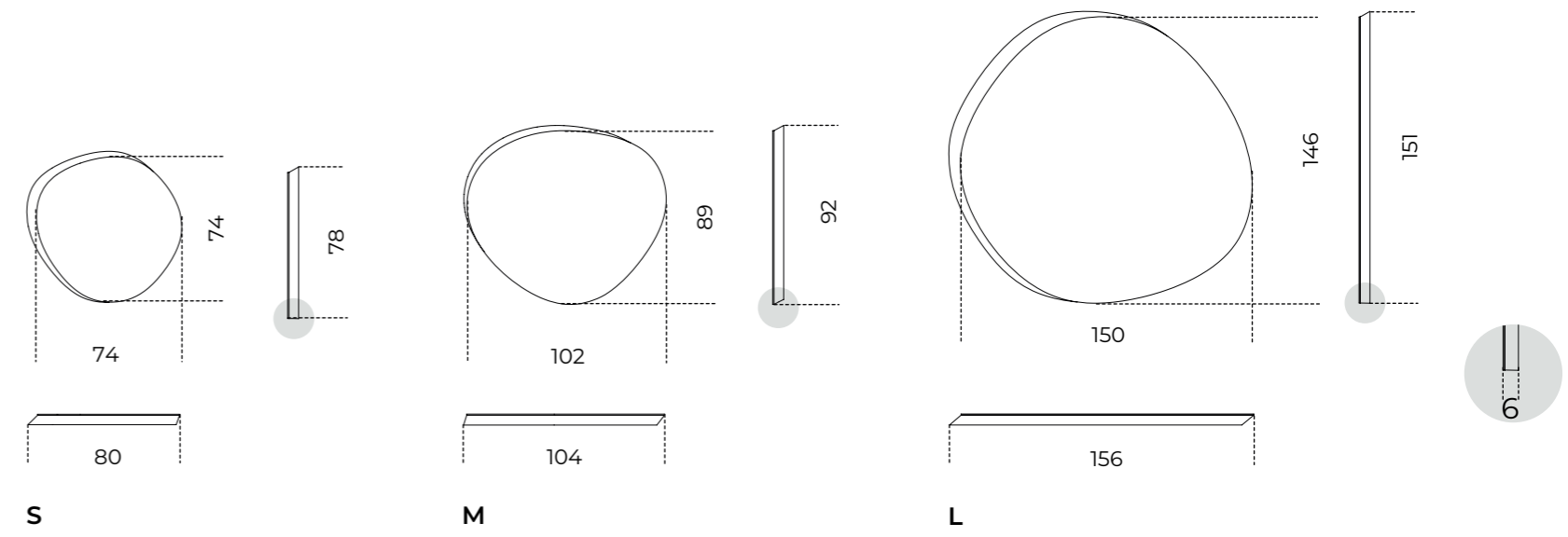

Sole | Studio G&R, 1975

Product information / p. 642

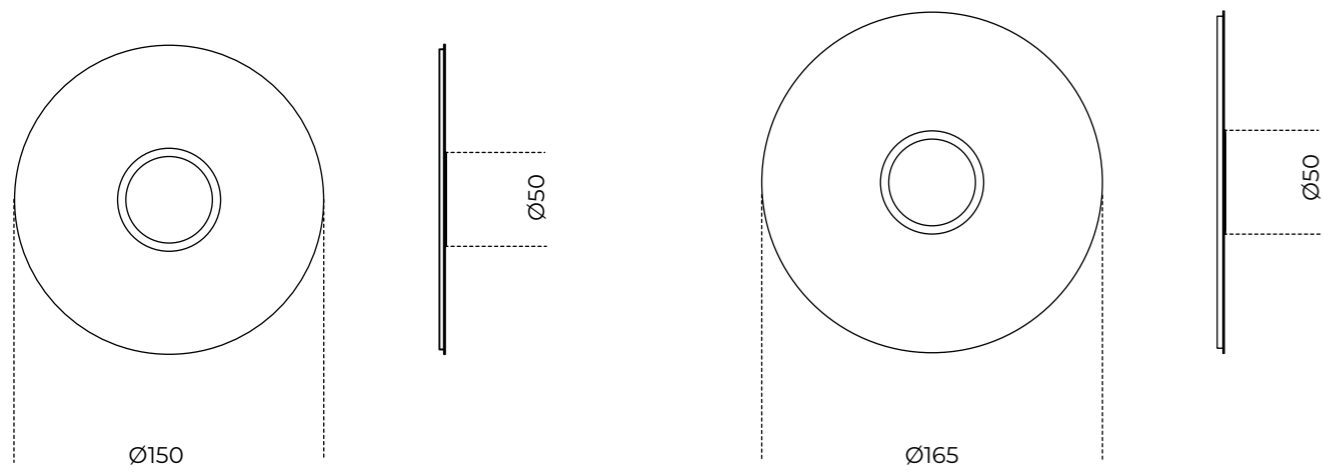

Zed | Ricardo Bello Dias, 2006

Product information / p. 644

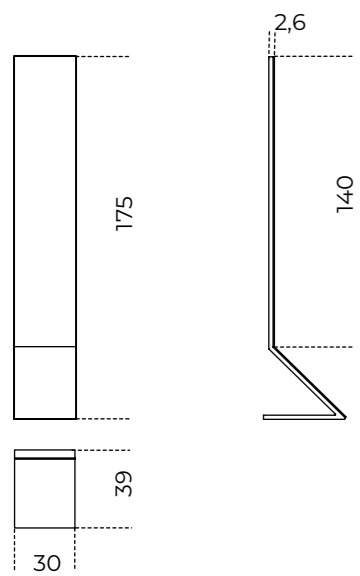



**16** Elementi decorativi /  
Decorative elements

658 [Lazy Susan](#)  
660 [Leaf Sculpture](#)

662 [Informazioni tecniche/  
Technical informations](#)



• **LAZY SUSAN**  
 Piano girevole in cristallo extralight con parte centrale retroverniciato liquirizia brillante  
 Rotating plate in extralight glass with bright liquorice black painted central part

# Lazy Susan

Studio G&R / 1986

Piano girevole in cristallo extralight 10mm molato a bisello (10mm) con parte centrale retroverniciata nei colori del campionario nella versione brillante. Disponibile versione completamente retroverniciata nei colori del campionario nella versione brillante o satinata. Può essere appoggiato su qualsiasi piano.

! Nella versione con parte centrale retroverniciata la retroverniciatura è realizzabile esclusivamente nella versione brillante.

Rotating plate in 10mm extralight glass with bevelled edge (10mm). Painted glass central part as per sample in the bright version. Also available version completely painted as per samples in the bright or satin version. It can be placed on any top.

! In the painted glass central part version the painting in the middle part can only be done in the bright version.



Cm	Inches
Ø 70	Ø 27¾"
Ø 75	Ø 29¾"
Ø 80	Ø 31½"
Ø 85	Ø 33½"
Ø 90	Ø 35½"
Ø 95	Ø 37½"
Ø 100	Ø 39½"

[For technical drawing / p. 664](#)

[Pricelist 2023 / p. 192](#)

## PIANO GIREVOLE E PARTE CENTRALE ROTATING PLATE/CENTRAL PART



Cristallo extralight/Cristallo retroverniciato  
 brillante nei colori del campionario  
 Extralight glass/Bright  
 painted glass as per samples

## PIANO GIREVOLE/ROTATING PLATE



Cristallo retroverniciato brillante/satinato  
 nei colori del campionario  
 Bright/satin painted glass  
 as per samples

# Leaf Sculpture

Ricardo Bello Dias / 2019

Sculpture in cristallo verniciate nella finitura metallo liquido color Avana e Lava. Montate su pannelli con diverse inclinazioni. Disponibili in composizioni predefinite. Strutture di collegamento in metallo laccato color brunito.

Sculptures in liquid metal lacquered glass in the colour Avana and Lava. Fixed on panels on different tilts. Available single or as per standard compositions. Burnished lacquered metal joint structure.

## NOTE TECNICHE SUI MATERIALI

**METALLO LIQUIDO** | La componente metallica della vernice fa sì che durante l'applicazione il naturale procedimento di ossidazione crei disomogeneità di sfumature che conferiscono carattere ed unicità alla superficie. Il procedimento naturale viene accentuato attraverso l'utilizzo di acidi e la spazzolatura permette di ottenere i due diversi colori.

## TECHNICAL INFORMATION ON THE MATERIALS

**LIQUID METAL** | The metallic component of the paint during the natural oxidation process creates uneven shades, that give uniqueness to the surface. The natural oxidation process is then enhanced by the use of acids and manual brushing to achieve the two different colours.



**Cm**  
Composizione 1  
215 x 200

Composizione 2  
180 x 235

**Inches**  
Composition 1  
84¾" x 78¾"

Composition 2  
71" x 92¾"

[For technical drawing / p. 664](#)

[Pricelist 2023 / p. 193](#)  
[Homescapes, sense of materials / p. 38](#)

## SCULTURE/SCULPTURES



Cristallo verniciato  
metallo liquido Avana e Lava  
Liquid metal lacquered  
Avana e Lava glass

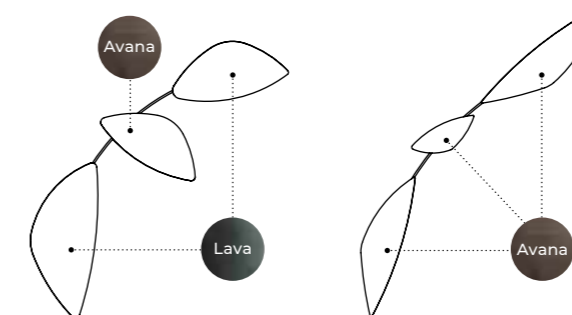

## STRUTTURA/STRUCTURE

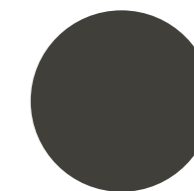

Metallo laccato  
color brunito  
Burnished lacquered metal

# 16

**Elementi Decorativi / Decorative Elements**  
**TECHNICAL MODULE**

Lazy Susan | Studio G&R, 1986

Product information / p. 658

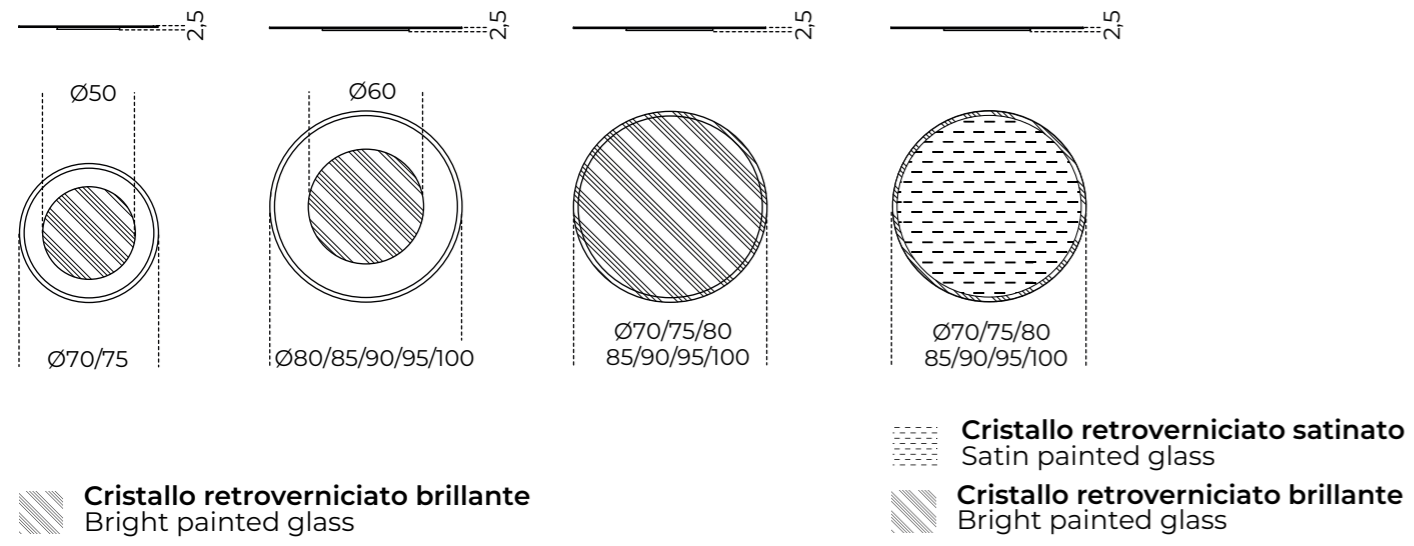

Leaf | Ricardo Bello Dias, 2012

Product information / p. 660

Composizione 1 / Composition 1

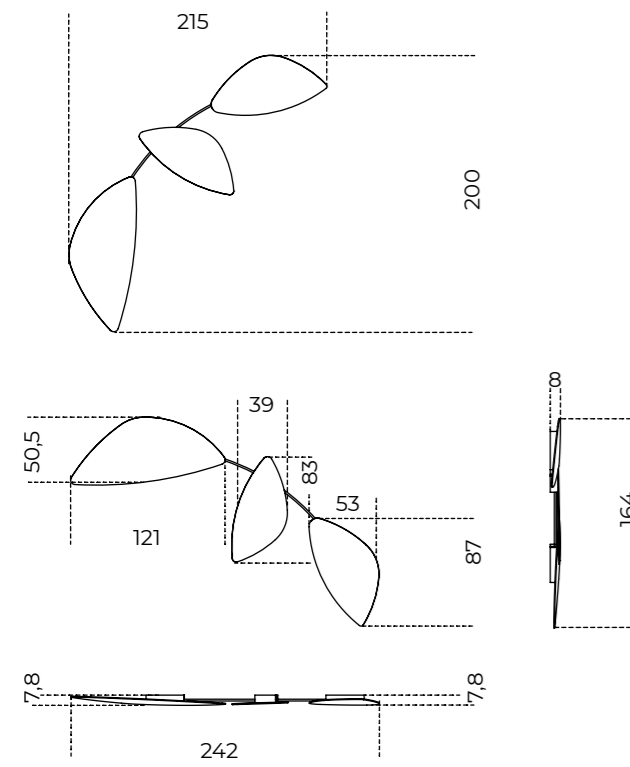

Composizione 2 / Composition 2

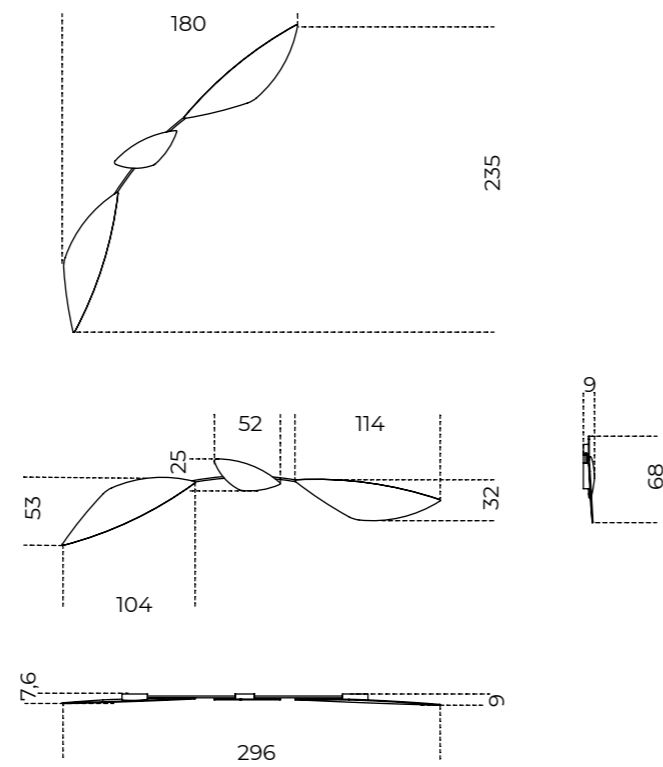

Combinazione 1 / Combination 1

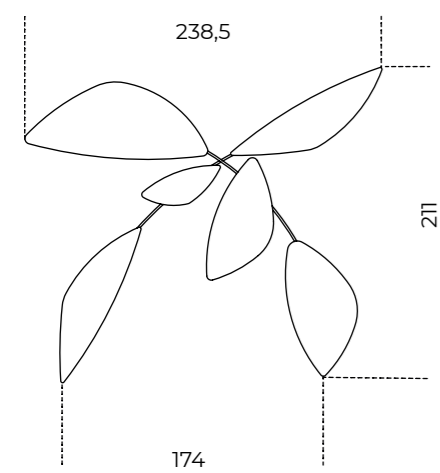

Combinazione 2 / Combination 2

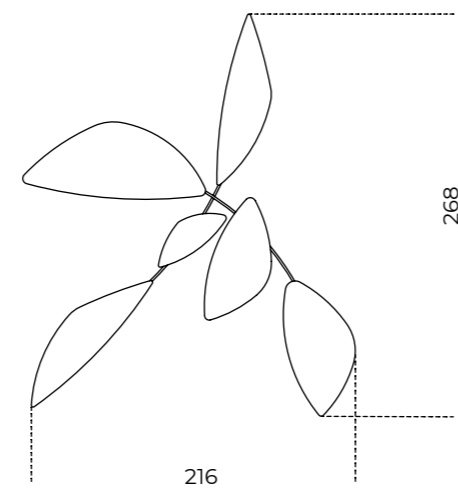

## **17** Tappeti / Rugs

668 **Ato**  
670 **Metaphores**  
674 **Resia**  
676 **Ruggy**

678 **Informazioni tecniche /**  
**Technical informations**



# Ato

Studio G&R/2024

Tappeto taftato a mano realizzato con lana della Nuova Zelanda. Ato è caratterizzato da un motivo geometrico astratto che si crea attraverso delle differenze di trame e altezze del pelo. Disponibile in tre colorazioni "sand", "dune" e "dust" realizzate attraverso tinture naturali. Su richiesta si realizzano dimensioni customizzate.

Hand tufted rug made from New Zealand wool. Ato is characterized by an abstract geometric pattern that is created through differences in pile textures and heights. Available in three colours "sand", "dune" and "dust" made through natural dyes. Customized dimensions are available upon request.

! Eventuali variazioni cromatiche sono dovute alla lavorazione artigianale del tappeto. I colori potrebbero risultare di tonalità differenti da una partita all'altra.

! Any slight color variation is due to the craftsmanship. Colors can be different, if dye bath change.



▲ "DUST"



▲ "DUNE"

[For technical drawing / p. 680](#)

	Cm	Inches
A	460 x 300	181¼" x 118¾"
B	485 x 410	191" x 161½"

PELO CORTO/SHORT PILE    PELO LUNGO/DEEP PILE



"Dust"



"Sand"



"Dune"



#### ▲ METAPHORES

Tappeto realizzato con: pelo corto beige e tessuto "Rigo" rosa "Dalia"  
Rug made with: beige short pile and "Dalia" rose "Rigo" fabric

# Metaphores

Studio G&R / 2023

**Tappeto composto da una composizione di materiali realizzati con tecniche diverse: pelo corto, pelo lungo e tessuto "Rigo".**  
Il tappeto a pelo corto è sempre realizzato nel colore beige,  
il tappeto a pelo lungo è sempre realizzato nel colore bianco.  
La parte in tessuto "Rigo" è tessuta e finita a mano e può essere realizzata in tre diversi colori: bianco "Conchiglia", rosa "Dalia" e grigio "Nuvola".  
L'unione degli diversi materiali è realizzata attraverso una termosaldatura.

! Eventuali variazioni cromatiche sono dovute alla lavorazione artigianale del tappeto.  
I colori potrebbero risultare di tonalità differenti da una partita all'altra.

Carpet composed of a composition of materials made with different techniques: short pile, long pile and "Rigo" fabric.  
The short pile carpet is always made in the color beige,  
the deep pile carpet is always made in the color white.  
The part in "Rigo" fabric is woven and finished by hand and can be made in three different colours: "Conchiglia" white, "Dalia" rose and "Nuvola" grey.  
The union of the different materials is achieved by heat-sealing.

! Any slight color variation is due to the craftsmanship.  
Colors can be different, if dye bath change.



Cm	Inches
A 432,5 x 420	170½" x 165½"
B 490 x 412,5	193" x 162½"
C 490 x 365	193" x 143¾"

[For technical drawing / p. 681](#)

[Pricelist 2023 / p. 195](#)  
[Homescapes, embracing beauty / pp. 48, 82, 106](#)  
[Homescapes, intimate portraits / p. 65](#)

#### PELO CORTO/SHORT PILE PELO LUNGO/DEEP PILE

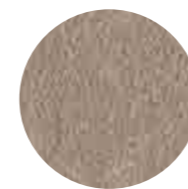

Beige  
Beige

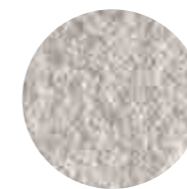

Bianco  
White

#### TESSUTO "RIGO"/"RIGO FABRIC

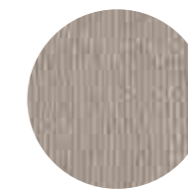

Bianco "Conchiglia"  
"Conchiglia" white



Rosa "Dalia"  
"Dalia" rose

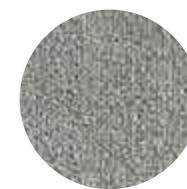

Grigio "Nuvola"  
"Nuvola" grey



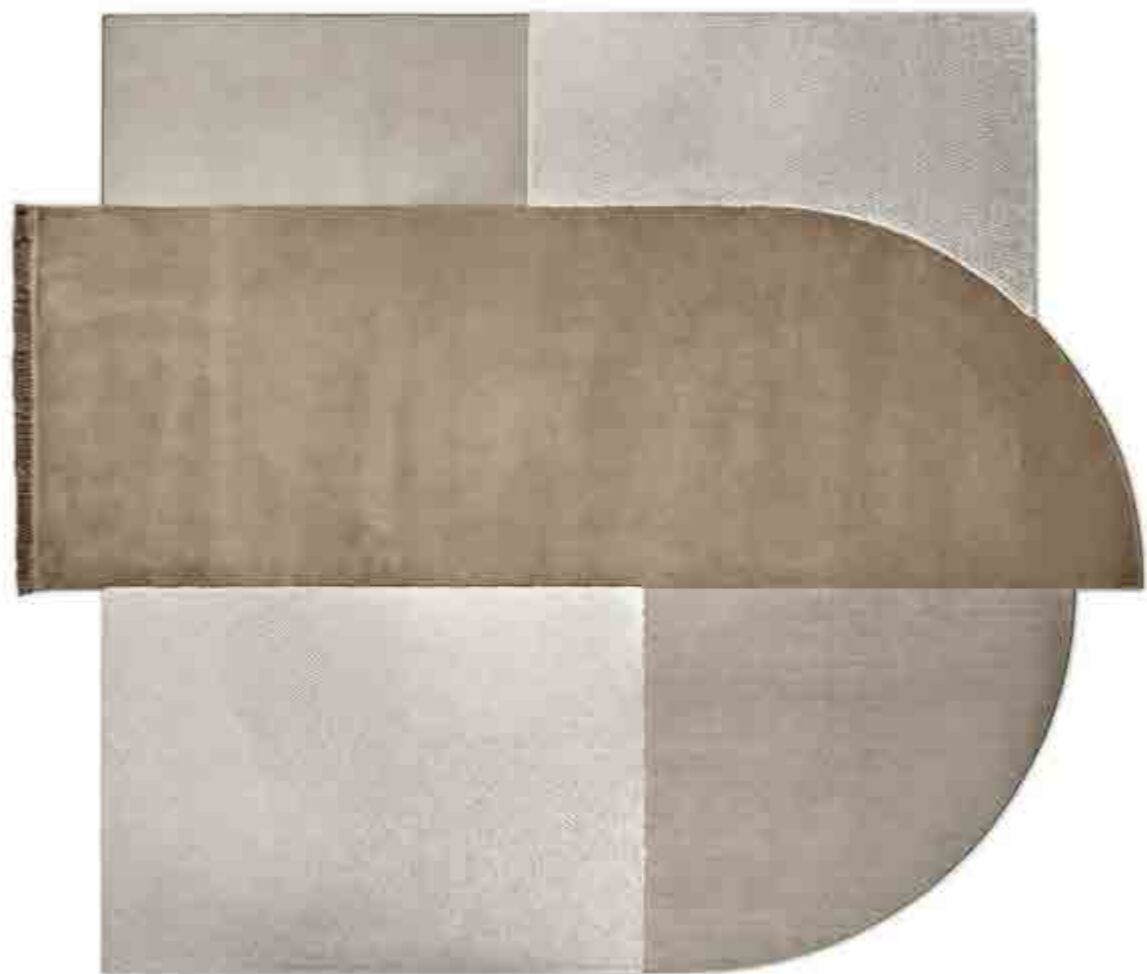

• METAPHORES

Tappeto realizzato con: pelo corto beige, pelo lungo bianco e tessuto "Rigo" bianco "Conchiglia"  
Rug made with: beige short pile, white deep pile and "Conchiglia" white "Rigo" fabric



• METAPHORES

Tappeto realizzato con: pelo corto beige, pelo lungo bianco e tessuto "Rigo" grigio "Nuvola"  
Rug made with: beige short pile, white deep pile and "Nuvola" grey "Rigo" fabric





• RESIA  
Tappeto Tea Rose  
Tea Rose rug

# Resia

Dainelli Studio / 2021

Tappeto a pelo corto effetto velluto, piacevole sia per l'occhio che al tatto. Il disegno caratterizzante è costituito da elementi geometrici. L'unione degli elementi geometrici e il bordo perimetrale sono realizzati in filo in tinta. Disponibili nei colori Tea Rose, Amazing Grey e Simply White. La morbida fibra sintetica di cui è composto garantisce un'eccezionale praticità e una semplice manutenzione.

! I colori potrebbero risultare di tonalità differenti da una partita all'altra.  
Le giunte tra due teli potrebbero risultare visibili.

Low pile rug with velvet effect, pleasant both to the eye and to the touch. The distinctive design consists of geometric elements. The joining of the geometric elements and the perimeter edge are made of matching yarn. Available in the colours Tea Rose, Amazing Grey and Simply White. The soft synthetic fibre of which it is composed guarantees an exceptional practicality and a simple maintenance.

! Colors can be different, if dye bath change.  
Joints between two sheets may be visible.



## Cm

400 x 350  
400 x 500  
450 x 260  
560 x 400

## Inches

157½" x 138"  
157½" x 197"  
177¼" x 102½"  
220½" x 157½"

[For technical drawing / p. 682](#)

[Pricelist 2023 / p. 196](#)  
[Homescapes, intimate portraits / p. 17](#)  
[Homescapes, gentle attitude / pp. 41, 43, 92, 93](#)

## VARIANTI COLORE/COLOR VARIANTS



Tea Rose



Amazing Grey



Simply White

# Ruggy

Massimo Castagna / 2020

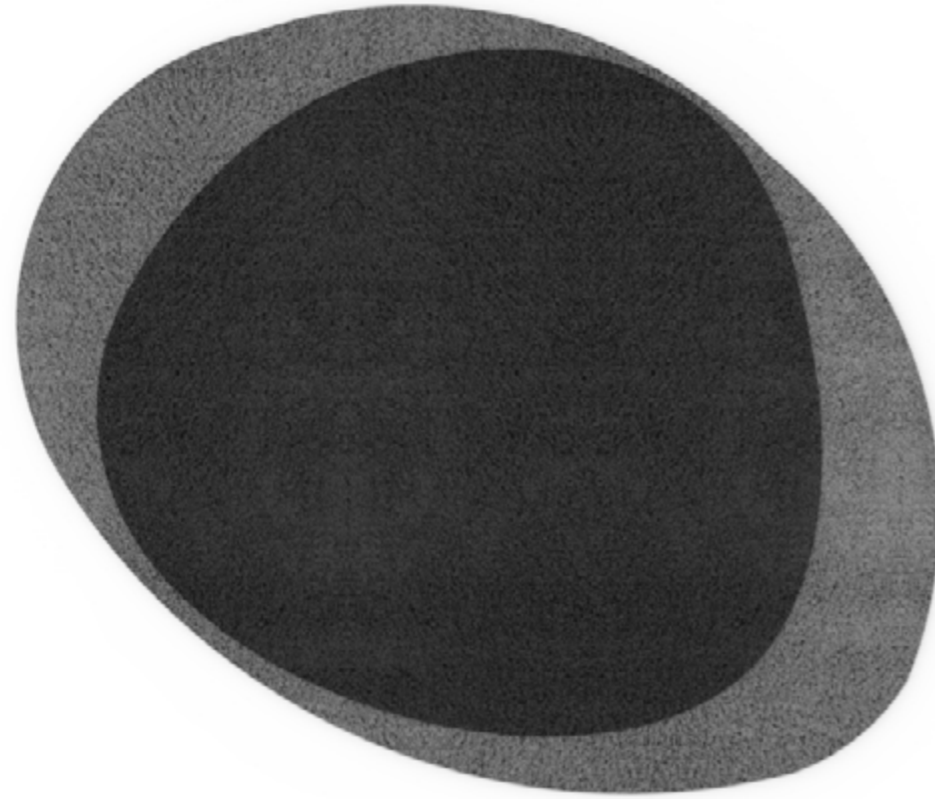

Tappeto bicolore a pelo alto in morbida fibra sintetica. Il vello è realizzato con la tecnica del tufting ed è molto morbido al tatto, con un marcato effetto scrivente. Il disegno caratterizzante è costituito da due forme organiche concentriche di differenti tonalità: ogni zona è termosaldata a quella vicina e ciò consente di non avere giunte visibili sulla superficie del tappeto. Il tappeto è bordato a filo, in tinta con le diverse aree di colore.

Disponibili in quattro combinazioni colore:

**Beige 01** – interno bianco, esterno beige  
**Beige 02** – interno beige, esterno bianco

**Grey 01** – interno grigio chiaro, esterno grigio scuro  
**Grey 02** – interno grigio scuro, esterno grigio chiaro

! I colori potrebbero risultare di tonalità differenti da una partita all'altra.  
 • Le giunte tra due teli potrebbero risultare visibili.

Two-tone deep pile rug in soft synthetic fiber. The pile is made using the tufting technic and is soft to the touch, with a strong marking effect. The distinctive design consists in two organic concentric shapes in different tones. These parts are heat sealed and this avoids visible joints on the rug's surface. The rug is flush edged in the same tone as the coloured areas. The natural colours offered and the iridescent nature of the fiber give character and refinement to every room.

Available in four colour combinations :

**Beige 01** – white inside, beige outside  
**Beige 02** – beige inside, white outside

**Grey 01** – light grey inside, dark grey outside  
**Grey 02** – dark grey inside, light grey outside

! Colors can be different, if dye bath change.  
 • Joints between two sheets may be visible.

## ▲ RUGGY

Tappeto bicolore combinazione Grey 02  
 Two-tone rug in Grey 021 color combination



## ▲ RUGGY

Tappeto bicolore combinazione Beige 01  
 Two-tone rug in Beige 01 color combination

**Cm**  
 Ø 388 x 330  
 Ø 455 x 400

**Inches**  
 Ø 152¾" x 130"  
 Ø 179¼" x 157½"

[For technical drawing / p. 683](#)

[Pricelist 2023 / p. 192](#)  
[Homescapes, embracing beauty / pp. 48, 82, 106](#)  
[Homescapes, intimate portraits / p. 65](#)

## COMBINAZIONI COLORE/COLOUR COMBINATIONS

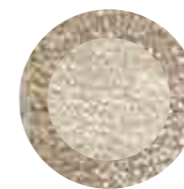

Beige 01

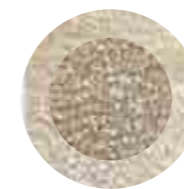

Beige 02

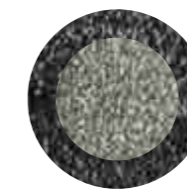

Grey 01

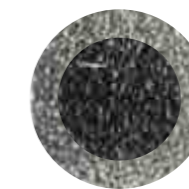

Grey 02

# 17

**Tappeti / Rugs**  
**TECHNICAL MODULE**

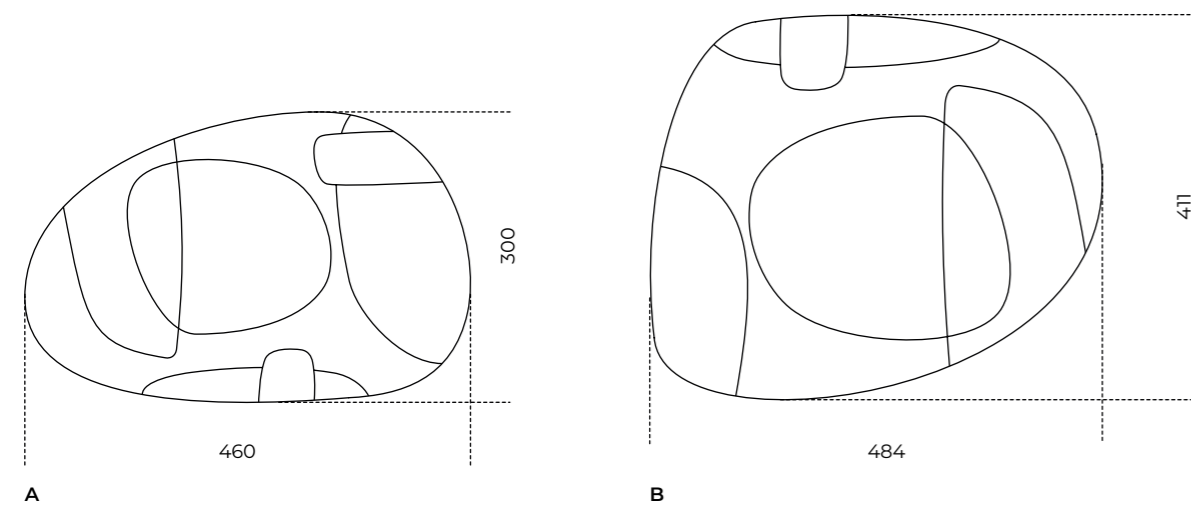
**Dati tecnici:**

<b>Costruzione</b>	Taftato a mano
<b>Composizione</b>	20% cut, 40% loop, 40% shaggy
<b>Sottofondo</b>	Lattice
<b>Spessore totale</b>	± 27mm
<b>Numero di punti</b>	Cut HT750, Loop H650, Shaggy HT850
<b>Reazione al fuoco</b>	Bfl - s1

**Technical details:**

<b>Construction</b>	Hand tufted
<b>Composition</b>	20% cut, 40% loop, 40% shaggy
<b>Backing</b>	Latex
<b>Total height</b>	± 27mm
<b>Tuft density</b>	Cut HT750, Loop H650, Shaggy HT850
<b>Flammability</b>	Bfl - s1

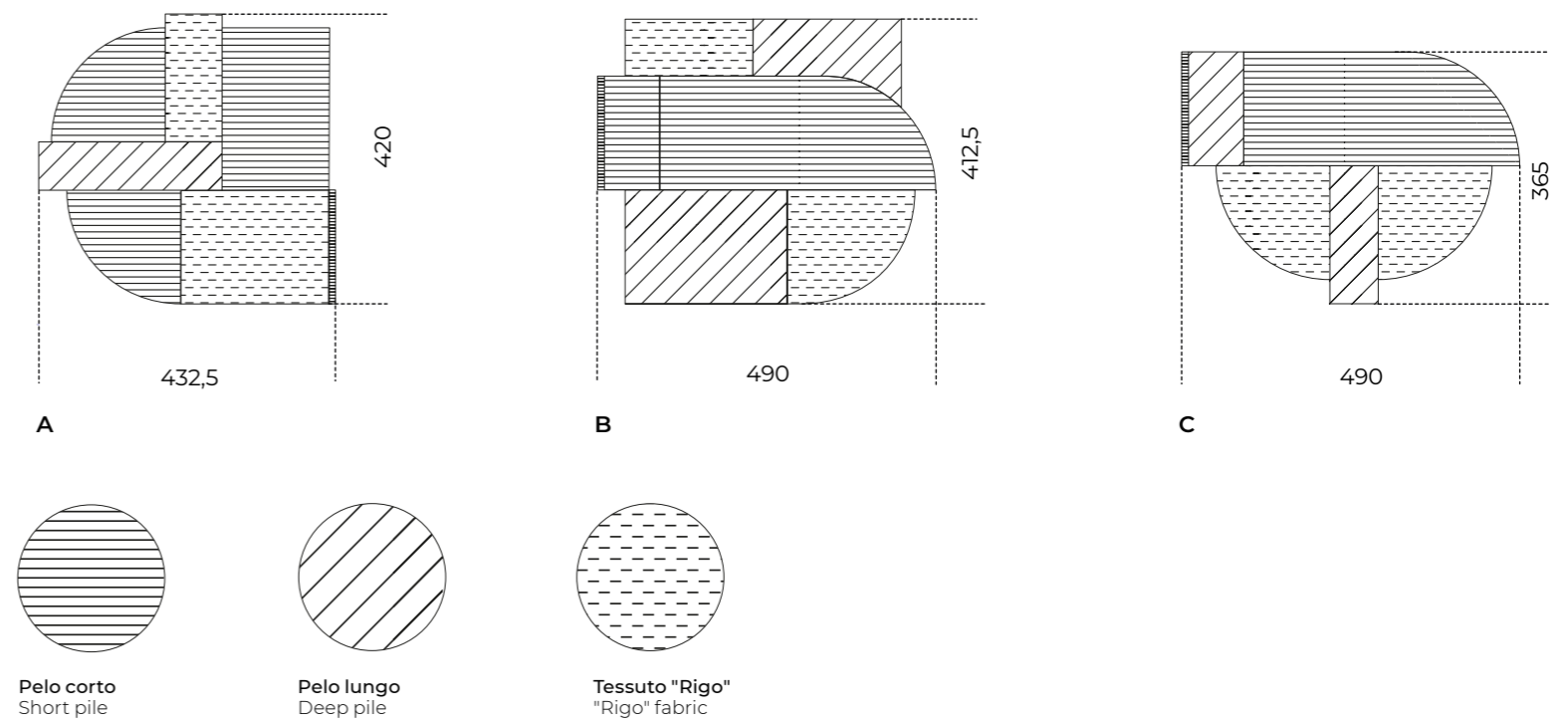
**Dati tecnici: pelo corto**

<b>Costruzione</b>	Plain saxony 5/64"
<b>Composizione</b>	100% PA IMPREL® Opal
<b>Sottofondo</b>	Twinback
<b>Spessore totale</b>	± 12 mm
<b>Peso totale</b>	± 2.600 gr/m <sup>2</sup>
<b>Numero di punti</b>	± 330.000/m <sup>2</sup>
<b>Altezza rotolo</b>	± 400 cm
<b>Reazione al fuoco</b>	Cfl - s1

**Technical details: short pile**

<b>Construction</b>	Plain saxony 5/64"
<b>Composition</b>	100% PA IMPREL® Opal
<b>Backing</b>	Twinback
<b>Total height</b>	± 12 mm
<b>Total weight</b>	± 2.600 gr/m <sup>2</sup>
<b>Tuft density</b>	± 330.000/m <sup>2</sup>
<b>Roll width</b>	± 400 cm
<b>Flammability</b>	Cfl - s1

**Dati tecnici: pelo lungo**

<b>Costruzione</b>	Berber Shaggy 1/8"
<b>Composizione</b>	100% PA IMPREL® Opal
<b>Sottofondo</b>	Twinback
<b>Altezza pelo</b>	± 9,5 mm
<b>Spessore totale</b>	± 13 mm
<b>Peso felpa</b>	± 2.500 gr/m <sup>2</sup>
<b>Peso totale</b>	± 3.200 gr/m <sup>2</sup>
<b>Numero di punti</b>	± 98.000/m <sup>2</sup>
<b>Altezza rotolo</b>	± 400 cm
<b>Reazione al fuoco</b>	Cfl - s1

**Technical details: deep pile**

<b>Construction</b>	Berber Shaggy 1/8"
<b>Composition</b>	100% PA IMPREL® Opal
<b>Backing</b>	Twinback
<b>Pile height</b>	± 9,5 mm
<b>Total height</b>	± 13 mm
<b>Pile weight</b>	± 2.500 gr/m <sup>2</sup>
<b>Total weight</b>	± 3.200 gr/m <sup>2</sup>
<b>Tuft density</b>	± 98.000/m <sup>2</sup>
<b>Roll width</b>	± 400 cm
<b>Flammability</b>	Cfl - s1

**Dati tecnici: tessuto "Rigo"**

<b>Composizione</b>	100% Polyamide 6.0
<b>Sottofondo primario</b>	Action Backing
<b>Sottofondo secondario</b>	Cotton Cloth
<b>Larghezza rotolo</b>	± 400 cm
<b>Peso pelo</b>	± 2.500 gr/m <sup>2</sup>
<b>Peso totale</b>	± 3.500 gr/m <sup>2</sup>
<b>Altezza pelo</b>	± 8 mm
<b>Altezza totale</b>	± 11 mm
<b>Reazione al fuoco</b>	Cfl-S1
<b>Zona di utilizzo</b>	Class 32
<b>Solidità alla luce</b>	≥ 5
<b>Indossabilità</b>	≥ 5
<b>Solidità all'acqua</b>	≥ 5
<b>TOG rating</b>	1,14

**Technical details: "Rigo" fabric**

<b>Composition</b>	100% Polyamide 6.0
<b>Primary backing</b>	Action Backing
<b>Secondary backing</b>	Cotton Cloth
<b>Roll width</b>	± 400 cm
<b>Pile weight</b>	± 2.500 gr/m <sup>2</sup>
<b>Total weight</b>	± 3.500 gr/m <sup>2</sup>
<b>Pile height</b>	± 8 mm
<b>Total height</b>	± 11 mm
<b>Fire Classification</b>	Cfl-S1
<b>Use area</b>	Class 32
<b>Light fastness</b>	≥ 5
<b>Wearability</b>	≥ 5
<b>Water fastness</b>	≥ 5
<b>TOG rating</b>	1,14

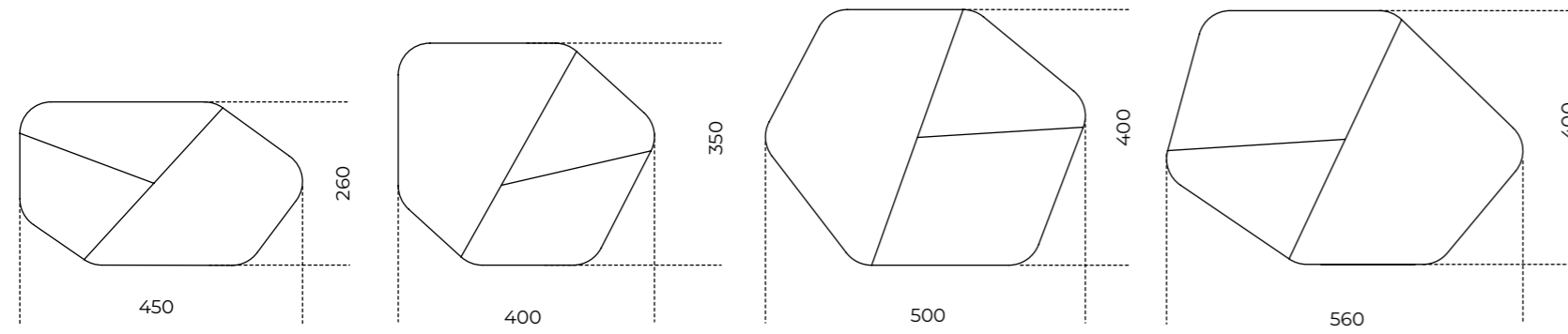

**Dati tecnici**

Aspetto	Velluto
Composizione	100% PA 6.6 Antron®
Costruzione	Tufting 1/10"
Peso felpa	1.950 gr/m <sup>2</sup>
Peso totale	2.750 gr/m <sup>2</sup>
Altezza felpa	9,00 mm
Altezza totale	11,4 mm
Punti inseriti	307.00/m <sup>2</sup>
Colorazione	Tinto in Pezza
Sottofondo	Juta CB
Altezza rotoli	2-4 m
Lunghezza rotoli	25.30 m
Reazione al fuoco	Bfl - s1
Classe di resistenza	23-33
Riduzione del suono	ΔLw 25 dB
Conducibilità termica	0,15 m2 K/W

**Technical details**

Aspect	Cut Pile
Composition	100% PA 6.6 Antron®
Construction	Tufting 1/10"
Pile weight	1.950 gr/m <sup>2</sup>
Total weight	2.750 gr/m <sup>2</sup>
Pile thickness	9,00 mm
Total thickness	11,4 mm
Number of Tufts	307.00/m <sup>2</sup>
Dyeing method	Continue
Backing	Action Back
Rolls width	2-4 m
Rolls length	25.30 m
Flammability	Bfl - s1
Resistance class	23-33
Impact sound reduction	ΔLw 25 dB
Thermal conductivity	0,15 m2 K/W

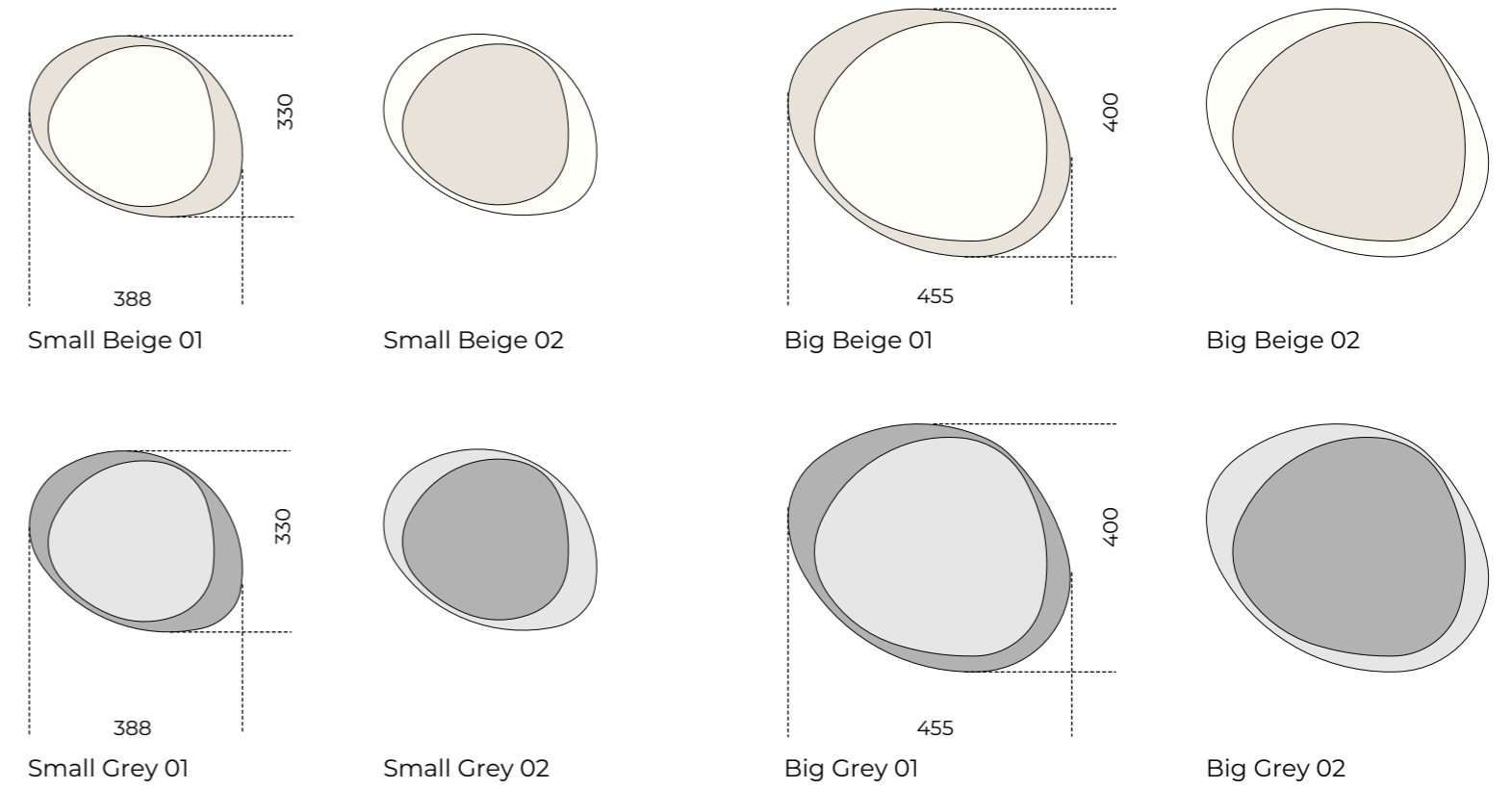
**Dati tecnici**

Costruzione	Tufting
Composizione	100% poliestere
Sottofondo	Geotessile satinato
Altezza pelo	±15
Altezza totale	±19
Peso totale	±3.700 gr/m <sup>2</sup>
Larghezza rotolo	400 cm
Reazione al fuoco	Cfl-s1

**Technical details**

Construction	Tufting
Composition	100% polyester
Backing	Satin geotextile
Pile height	±15
Total height	±19
Total weight	±3.700 gr/m <sup>2</sup>
Rolls width	400 cm
Flammability	Cfl-s1

## **18 Accessori /**

Accessories

- [686](#) [Vase 1968](#)
- [688](#) [Candle Holder](#)
- [689](#) [Candle Holder Hexagonal](#)
- [690](#) [Desk Card Holder](#)
- [692](#) [Desk Set](#)
- [694](#) [Flabello](#)
- [696](#) [Folded Tray](#)
- [698](#) [Iperboarea](#)
- [700](#) [Moonlight](#)
- [701](#) [Mouse Pad](#)
- [702](#) [Odette Tray](#)
- [704](#) [Paperweight](#)
- [706](#) [Pleiadi](#)
- [708](#) [Segno](#)
- [709](#) [Teddy](#)
- [710](#) [Tic Tac 14](#)
- [712](#) [Tip Tap Toe](#)
  
- [714](#) [Informazioni tecniche/  
Technical informations](#)



# Vase 1968

Silvia Gallotti / 2018

Vaso in ottone satinato e marmo levigato opaco Nero Marquinia o Calacatta Vagli Oro. Disponibile versione con due (M2) o tre marmi (M3). Riedizione del 1968.

## NOTE TECNICHE SUI MATERIALI

**MARMO** | Il marmo è un materiale naturale di origine sedimentaria che può presentare particolarità come venature, lievi irregolarità superficiali, colorazioni differenti e cristallizzazioni. Queste disomogeneità sono da attribuirsi alla naturalezza del materiale e non sono da considerarsi difetti ma caratteristiche tipiche del marmo. Ogni prodotto risulterà unico, esclusivo e non replicabile.

Vase in satin brass and honed mat Nero Marquinia or Calacatta Vagli oro marble. Available version with two (M2) or three marbles (M3). Re-edition of 1968.

## TECHNICAL INFORMATION ON THE MATERIALS

**MARBLE** | Il marmo è un materiale naturale di origine sedimentaria che può presentare particolarità come venature, lievi irregolarità superficiali, colorazioni differenti e cristallizzazioni. Queste disomogeneità sono da attribuirsi alla naturalezza del materiale e non sono da considerarsi difetti ma caratteristiche tipiche del marmo. Ogni prodotto risulterà unico, esclusivo e non replicabile.



	Cm	Inches
M2	10 x 10 x 23	4" x 4" x 9 1/4"
M3	10 x 10 x 23	4" x 4" x 9 1/4"

For technical drawing / p.716

Pricelist 2023 / p.314

## STRUTTURA



Ottone satinato/  
Marmo levigato opaco  
Nero Marquinia  
Satin brass/ Honed mat  
Nero Marquinia marble



Ottone satinato/  
Marmo levigato opaco  
Calacatta Vagli Oro  
Satin brass/ Honed mat  
Calacatta Vagli Oro marble



# Candle Holder

Studio G&R / 2014

Porta candele in ottone massiccio lucido. Set di due pezzi.

Candle holders in solid bright brass. Set of two.



**Cm**  
Ø3 x 4 x 20

**Inches**  
Ø1" x 1¼" x 8"

[For technical drawing / p.716](#)

[Pricelist 2023 / p.315](#)

## STRUTTURA/STRUCTURE



**Ottone lucido**  
Bright brass

# Candle Holder Hexagonal

Studio G&R / 2014

Porta candele esagonali in ottone massiccio lucido all'esterno e opaco all'interno. Set di tre pezzi.

Hexagonal candle holders in solid bright brass outside and opaque brass inside. Set of three.



**Cm**  
Ø5 x 5 x 6

**Inches**  
Ø 2" x 2" x 2½"

[For technical drawing / p.716](#)

[Pricelist 2023 / p.316](#)

## STRUTTURA/STRUCTURE



**Ottone lucido**  
Bright brass



# Desk Card Holder

Studio G&R / 2014

Porta biglietti da visita in ottone massiccio lucido.

Desk card holder in solid bright brass.



**Cm**  
Ø 7 x 4

**Inches**  
Ø 3" x 1 1/4"

[For technical drawing / p.217](#)

[Pricelist 2023 / p.317](#)

## STRUTTURA/STRUCTURE



**Ottone lucido**  
Bright brass



# Desk Set

Silvia Gallotti / 2019

Organizer da scrivania in ottone satinato con tre elementi in appoggio: un portabiglietti in marmo Verde Alpi spazzolato, un calendario in frassino tinto nero a poro aperto e un portapenne in cristallo trasparente da 24mm.

## NOTE TECNICHE SUI MATERIALI

**MARMO** | Il marmo è un materiale naturale di origine sedimentaria che può presentare particolarità come venature, lievi irregolarità superficiali, colorazioni differenti e cristallizzazioni. Queste peculiarità sono da attribuirsi alla naturalezza del materiale e non sono da considerarsi difetti ma caratteristiche tipiche del marmo. Ogni prodotto risulterà unico, esclusivo e non replicabile.

Desk organizer in satin brass with three freestanding elements: a business card holder in Verde Alpi brushed marble, a calendar in black stained open pore ash and a 24mm pen holder in transparent glass.

## TECHNICAL INFORMATION ON THE MATERIALS

**MARBLE** | The marble is a natural material of sedimentary origin that can present particularities such as veins, slight surface irregularities, different colors and crystallizations. These peculiarities are to be attributed to the naturalness of the material and are not to be considered defects but typical characteristics of marble. Each product will be unique, exclusive and non-replicable.



**Cm**  
27 x 9,3 x 3,6

**Inches**  
10¾" x 3¾" x 1½"

For technical drawing / p.717

Pricelist 2023 / p. 318

## STRUTTURA/STRUCTURE



Ottone satinato  
Satin brass

## PORTABIGLIETTI/ BUSINESS CARD HOLDER



Marmo Verde Alpi  
spazzolato  
Verde Alpi brushed  
marble

## CALENDARIO/CALENDAR

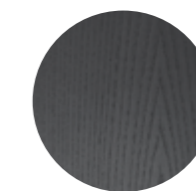

Frassino tinto  
nero poro aperto  
Black stained  
open pore ash

## PORTA PENNE/PEN HOLDER



Cristallo trasparente  
Transparent glass



# Flabello

Lanzavecchia + Wai / 2017

Specchio da tavolo 4mm, argentato ed anticato a mano. Base in frassino tinto nero a poro aperto e ottone lucido.

4mm hand silver-plated and antiqued table mirror. Black open pore stained ash base and bright brass.



	Cm	Inches
S	32 x 10 x 30	12 <sup>3</sup> / <sub>4</sub> " x 4" x 12"
M	40 x 15 x 38	15 <sup>3</sup> / <sub>4</sub> " x 6" x 15"
L	50 x 10 x 25	19 <sup>3</sup> / <sub>4</sub> " x 4" x 10"

[For technical drawing / p.717](#)

[Pricelist 2023 / p.319](#)

## SPECCHIO/MIRROR

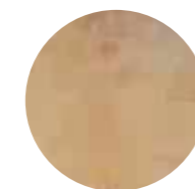

Specchio argentato-  
anticato a mano  
Hand silver-  
plated and antiqued mirror

## BASE/BASE

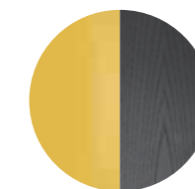

Frassino tinto nero poro aperto/  
Ottone lucido  
Black stained open pore ash/  
Bright brass

# Folded Tray

Studio G&R / 2014

Vassoio in ottone satinato e specchio anticato, disponibile nella finitura "Antique 1" o "Antique 2". A richiesta anche in ottone argentato satinato.

Tray in satin brass and antiqued mirror. Available in the "Antique 1" or "Antique 2" finish. Satin silver-plated brass, on request.

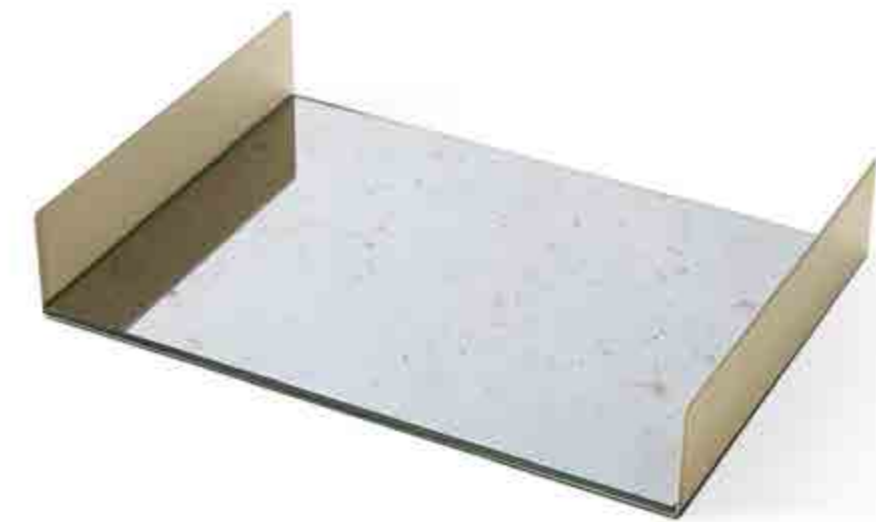

**Cm**  
26 x 35,5 x 6

**Inches**  
10 3/4" x 14" x 2 1/2"

[For technical drawing / p.718](#)

[Pricelist 2023 / p.320](#)

## LATI E BASE/SIDES AND BASE



**Ottone satinato**  
Satin brass



**Ottone satinato argentato**  
Satin silver-plated brass

## PIANO/TOP



**Specchio "Antique 1"**  
"Antique 1" mirror



**Specchio "Antique 2"**  
"Antique 2" mirror

▲ **FOLDER TRAY**  
Piano in specchio "Antique 1" / Lati e base in ottone satinato  
"Antique 1" mirror top / Satin brass sides and base



\* FOLDER TRAY  
 Piano in specchio Antique 17, lati e base in ottone satinato  
 Antique 17 mirror top, satin brass sides and base

# Iperborea

Studiopepe/2024

Wall hanging realizzato in seta pura, tinta con colori naturali, ricamata a mano da prestigiosi artigiani italiani.  
 Per ogni pannello sono necessarie circa 300 ore di lavoro.  
 Può essere posizionato orizzontalmente o verticalmente.

Wall hanging in pure silk, dyed with natural colors, embroidered by hand by prestigious Italian artisans  
 About 300 working hours are needed for each panel  
 It can be positioned horizontally or vertically.



**Cm**  
200 x 180

**Inches**  
78¾" x 71"

For technical drawing / p.718

Pricelist 2023 / p.320

SETA/SILK

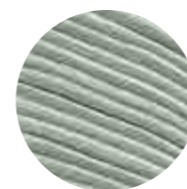

**Acquamarina**  
Aquamarine



**Beige**  
Beige

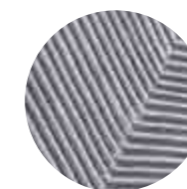

**Grigio**  
Grey



**Rosa**  
Pink

# Moonlight

Silvia Gallotti / 2017

Set di 6 sottopiatte in cristallo 4mm decorato a mano. Sfumature nei toni del nero e nichel sul fronte e nichel satinato spazzolato incrociato sul retro.

## NOTE TECNICHE SUI MATERIALI

**CRISTALLO** | Le finiture esclusive risultato del processo di lavorazione manuale realizzata sul cristallo possono presentare macchie e striature, oltre a differenze cromatiche.

Tali disomogeneità sono caratteristiche che non devono essere considerate difetti ma elementi distintivi che esaltano la bellezza e la peculiarità del pezzo unico.

Set di 6 sottopiatte in cristallo 4mm decorato a mano. Sfumature nei toni del nero e nichel sul fronte e nichel satinato spazzolato incrociato sul retro.

## TECHNICAL INFORMATION ON THE MATERIALS

**GLASS** | Artisanal and exclusive finishes that are obtained from the oxidation of silver, gold and copper leaves may show marks and spots, as well as variations in colour. These differences are inevitable and should not be considered imperfections but evidence of the hand-crafted process. They enhance the beauty and distinctiveness of a unique piece.

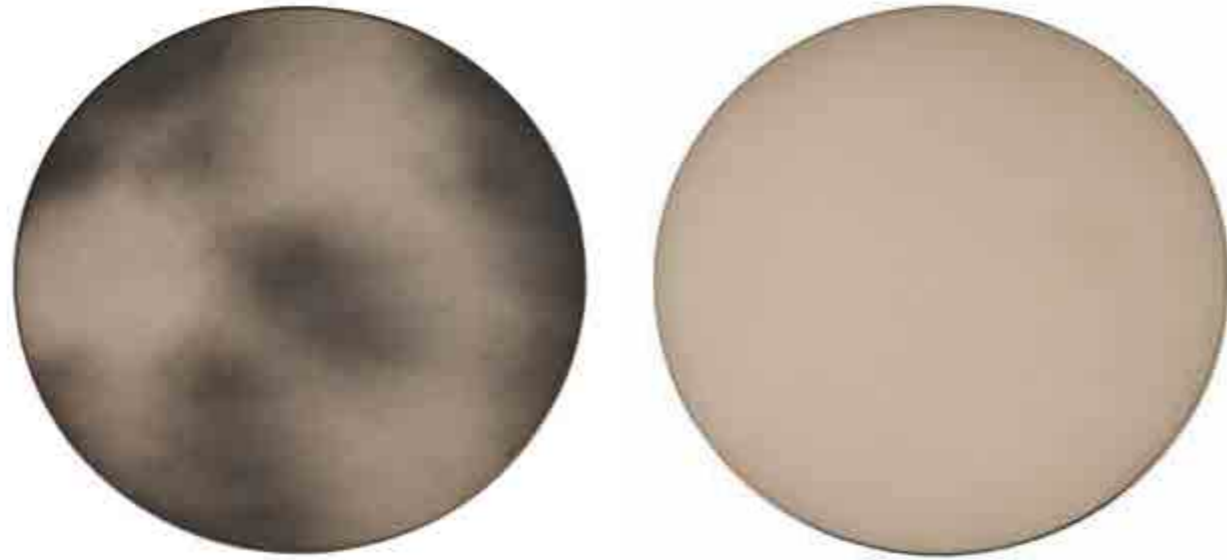

Cm  
Ø 33

Inches  
Ø 13"

[For technical drawing / p.718](#)

[Pricelist 2023 / p. 321](#)

## FRONTE/FRONT



**Cristallo sfumato  
nero e nichel**  
Glass with shades in  
black and nichel colours

## RETRO/BACK



**Cristallo nichel satinato  
spazzolato incrociato**  
Satin nickel hand brushed  
glass with woven pattern

# Mouse Pad

Studio G&R / 2009

Mouse pad in cristallo retroverniciato satinato nei colori del campionario. Logo Gallott&Radice serigrafato sul bisello.

Satin painted glass mouse pad as per samples. Gallotti&Radice screen printed logo on the bevel.



Cm  
23 x 23

Inches  
9¼" x 9¼"

[For technical drawing / p.719](#)

[Pricelist 2023 / p. 322](#)

## STRUTTURA/STRUCTURE



**Cristallo retroverniciato  
satinato nei colori del  
campionario**  
Satin painted glass as  
per samples

# Odette Tray

Studio G&R / 2014

Vassoio in specchio anticato disponibile nella finitura "Antique 1" o "Antique 2".  
Supporto in metallo ottonato lucido.

Tray in antiqued mirror available in the "Antique 1" or "Antique 2" finish. Bright brass-plated metal support.



**Cm**  
38,5 x 30 x 4  
50 x 26,5 x 4

**Inches**  
15¼" x 12" x 1¾"  
19¾" x 10½" x 1¾"

For technical drawing / p.719

Pricelist 2023 / p.323

## VASSOIO/TRAY



Specchio "Antique 1"  
"Antique 1" mirror



Specchio "Antique 2"  
"Antique 2" mirror



Cristallo Decò  
Decò glass

## SUPPORTO/SUPPORT



Metallo ottonato  
Brassed metal

• ODETTE TRAY  
Specchio "Antique 2" / Supporto in metallo ottonato  
"Antique 2" mirror / Brass-plated metal support





# Paperweight

Studio G&R/2014

Fermacarte in ottone massiccio lucido. Disponibile in tre versioni.

Paperweight in solid bright brass. Available in three versions.



Cm  
Ø12 x 1

Inches  
Ø4¾" x ½"

[For technical drawing / p.719](#)

[Pricelist 2023 / p.324](#)

## STRUTTURA/STRUCTURE



Ottone lucido  
Bright brass



# Pleiadi

Sutdiopepe/2023

Rivestimento decorativo realizzato in linters di cotone e argille e ottenuto tramite un processo di lavorazione artigianale a freddo. I linters sono la peluria corta che avvolge il seme del cotone dopo la prima sgranatura. Staccati, con una seconda e più energica sgranatura, forniscono fibre di cellulosa molto pura, solitamente utilizzate nell'industria cartaria o per la produzione di ovatte, stoppini, feltri e filati di viscosa.

La mattonella decorativa Pleiadi è ecologica e sostenibile, offrendo una nuova vita e una nuova funzionalità a quello che viene generalmente considerato uno scarto della produzione del cotone.

Disponibile nel colore "nature", una finitura ispirata al mondo naturale, ottenuta anch'essa in modo artigianale con la miscelazione di terre naturali e senza l'aggiunta di coloranti artificiali né di mordenti. Ciascuna mattonella misura 20x20 cm e può essere posizionata sia orizzontalmente che verticalmente per creare diverse composizioni ed effetti grafici.

Trattandosi di un prodotto realizzato artigianalmente e manualmente, la dimensioni potrebbero variare leggermente. La composizione in cellulosa di Pleiadi garantisce elevate performance di assorbimento sonoro a fronte di spessori estremamente ridotti.

! Trattandosi di un prodotto realizzato artigianalmente e manualmente, la dimensioni potrebbero variare leggermente.

## NOTE TECNICHE SUI MATERIALI

**FINITURE ARTIGIANALI** | Le finiture manuali ed esclusive risultato del processo di ossidazione di foglia argento, oro e rame possono presentare macchie e striature, oltre a differenze cromatiche. Tali disomogeneità sono caratteristiche che non devono essere considerate difetti ma elementi distintivi, tipici dell'ossidazione manuale, che esaltano la bellezza e la peculiarità del pezzo unico.

Decorative wallcovering made of cotton linters and clays and obtained through a cold craft process. Linters are the short downy hairs or fuzz adhering to the cotton seeds. After removal from the seeds, the linters receive a second, more energetic ginning to produce very pure cellulose fibres, mostly used for paper, wadding, wicks, felt and viscose yarns.

The decorative tile Pleiadi is ecological and sustainable, giving a new life and new use to what is generally considered a by-product of the cotton industry.

Available in 'nature' colour, a natural finish obtained in a low-tech process by mixing earth without artificial dyes or mordant.

Each tile measures 20x20 cm and can be placed both horizontally and vertically to create different compositions and graphic effects

As this is a handcrafted and manually made product, the dimensions may vary slightly. The cellulose composition of Pleiadi guarantees high sound absorption performance against extremely low thicknesses

! As this is a handcrafted and manually made product, the dimensions may vary slightly.

## TECHNICAL INFORMATION ON THE MATERIALS

**ARTISANAL FINISHES** | Artisanal and exclusive finishes that are obtained from the oxidation of silver, gold and copper leaves may show marks and spots, as well as variations in colour. These differences are inevitable and should not be considered imperfections but evidence of the hand-crafted process. They enhance the beauty and distinctiveness of a unique piece.

**AL MOMENTO NON DISPONIBILI  
CURRENTLY NOT AVAILABLE**

**Cm**  
20 x 3 x 20

**Inches**  
8" x 1¼" x 8"

[For technical drawing / p. 720](#)

[Pricelist 2023 / p. 271](#)

## LINTERS DI COTONE E ARGILLE/ COTTON LINTERS AND CLAYS



"Nature"

# Segno

Elisa Ossino / 2018

Segnalibro in ottone satinato. Set di due pezzi.

Satin brass bookmark. Set of two.



**Cm**  
Ø6,5  
3,5 x 8

**Inches**  
Ø2¾"  
1½" x 3¼"

[For technical drawing / p. 720](#)

[Pricelist 2023 / p. 326](#)

## STRUTTURA/STRUCTURE



**Ottone satinato**  
Satin brass

# Teddy

Studio G&R / 2023

Cuscino decorativo rivestito in pregiata pelliccia ecologica piacevole al tatto e dotata di un pelo fitto. Disponibile nei colori: thrill silver 701, thrill ecru 901, thrill blueberry 001 e thrill silt 101.

Decorative cushion covered by finest faux furs pleasant to the touch and with a dense pile. Available in the colours: thrill silver 701, thrill ecru 901, thrill blueberry 001 and thrill silt 101.



**Cm**  
Ø38  
40 x 40  
60 x 60  
35 x 25  
70 x 38

**Inches**  
Ø15  
15¾" x 15¾"  
23¾" x 23¾"  
14" x 10"  
27¾" x 1"

[For technical drawing / p. 721](#)

[Pricelist 2023 / p. 327](#)

## RIVESTIMENTO/COVER

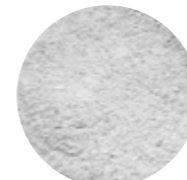

**Pelliccia ecologica**  
Thrill silver 701  
Faux furs  
Thrill silver 701



**Pelliccia ecologica**  
Thrill ecru 901  
Faux furs  
Thrill ecru901



**Pelliccia ecologica**  
Thrill blueberry 001  
Faux furs  
Thrill blueberry 001



**Pelliccia ecologica**  
Thrill silt 101  
Faux furs  
Thrill silt 101

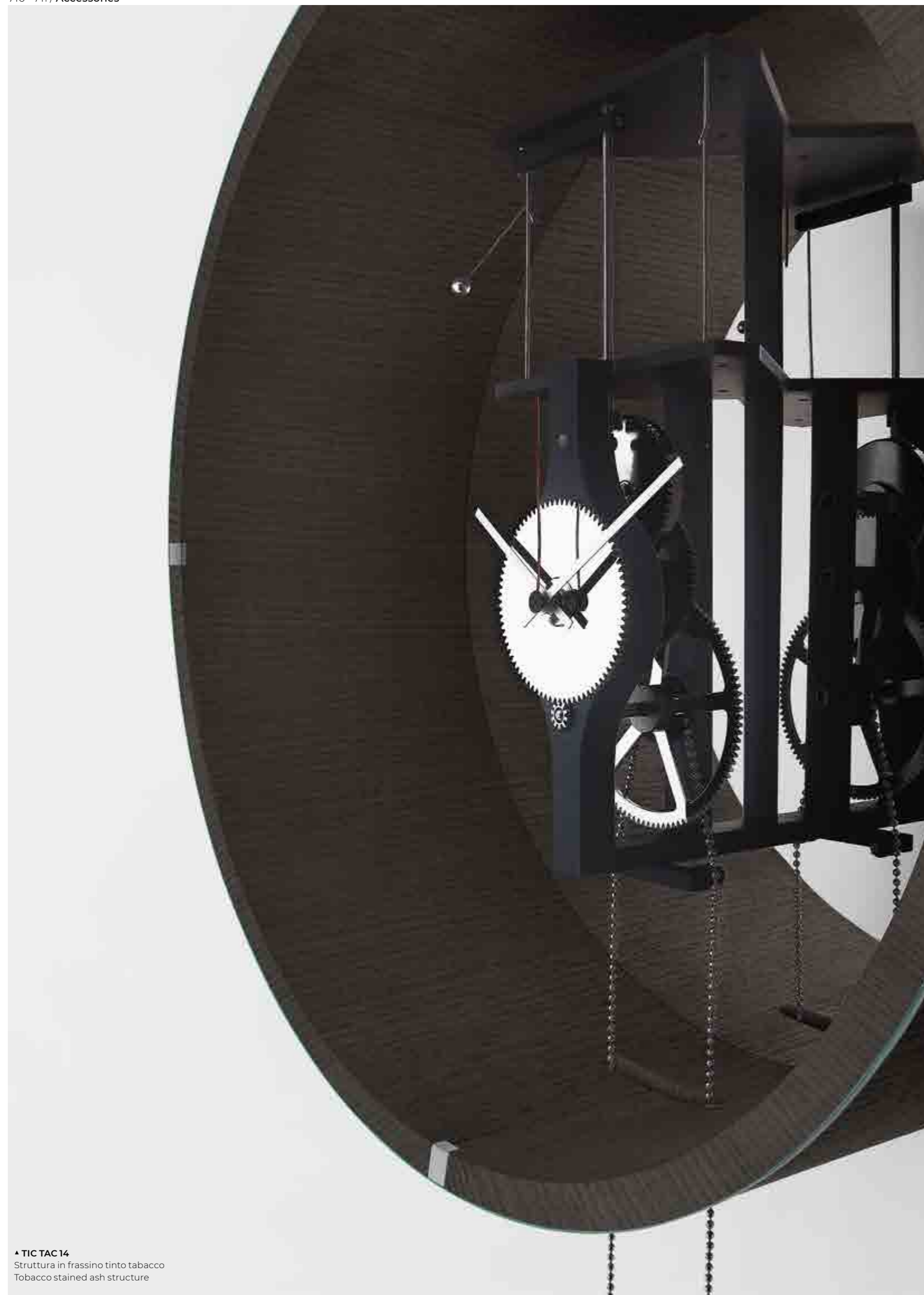

▲ **TIC TAC 14**  
Struttura in frassino tinto tabacco  
Tobacco stained ash structure

# Tic Tac 14

Studio G&R / 2014

Orologio a pendolo con caricamento manuale. Struttura in frassino tinto tabacco o nero poro aperto. Frontale in cristallo extralight 6mm bisellato. Fondo in acciaio inox lucido "supermirror" Meccanismo in alluminio anodizzato nero e ottone cromato. Orologio con funzione a batteria. Su richiesta, incisione personalizzata sulla ghiera in acciaio inox.

! Per incisione necessario file dwg.

Manual winding pendulum clock. Tobacco stained or black open pore stained ash structure and 6mm extralight bevelled front glass. "Supermirror" bright stainless steel back. Black anodised aluminium and chromed brass mechanism. Striking mechanism clock. Customized engraving on the bright stainless steel ring, on request.

! For engraving dwg file required.



**Cm**  
Ø50 x 20 x 175

**Inches**  
Ø19¾" x 8" x 69"

[For technical drawing / p. 721](#)

[Pricelist 2023 / p. 203](#)

## STRUTTURA/STRUCTURE



Frassino tinto tabacco  
Tobacco open pore  
stained ash

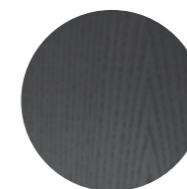

Frassino tinto  
nero poro aperto  
Black open pore  
stained ash

## FRONTALE/FRONT



Cristallo extralight  
Extralight mirror

## FONDO/BACK



Acciaio Inox lucido  
Bright stainless steel

## MECCANISMO/ MECHANISM



Alluminio anodizzato nero/  
ottone cromato  
Black anodised aluminium/  
chromed brass



# Tip Tap Toe

Silvia Gallotti / 2017

Gioco da tavolo in marmo lucido naturale Nero Marquinia e ottone massiccio. Pedine in ottone lucido e satinato.

Table game in natural polished Nero Marquinia marble and solid brass. Pawns in bright and satin brass.

## NOTE TECNICHE SUI MATERIALI

**MARMO** | Il marmo è un materiale naturale di origine sedimentaria che può presentare particolarità come venature, lievi irregolarità superficiali, colorazioni differenti e cristallizzazioni. Queste disomogeneità sono da attribuirsi alla naturalezza del materiale e non sono da considerarsi difetti ma caratteristiche tipiche del marmo. Ogni prodotto risulterà unico, esclusivo e non replicabile.

## TECHNICAL INFORMATION ON THE MATERIALS

**MARBLE** | Il marmo è un materiale naturale di origine sedimentaria che può presentare particolarità come venature, lievi irregolarità superficiali, colorazioni differenti e cristallizzazioni. Queste disomogeneità sono da attribuirsi alla naturalezza del materiale e non sono da considerarsi difetti ma caratteristiche tipiche del marmo. Ogni prodotto risulterà unico, esclusivo e non replicabile.

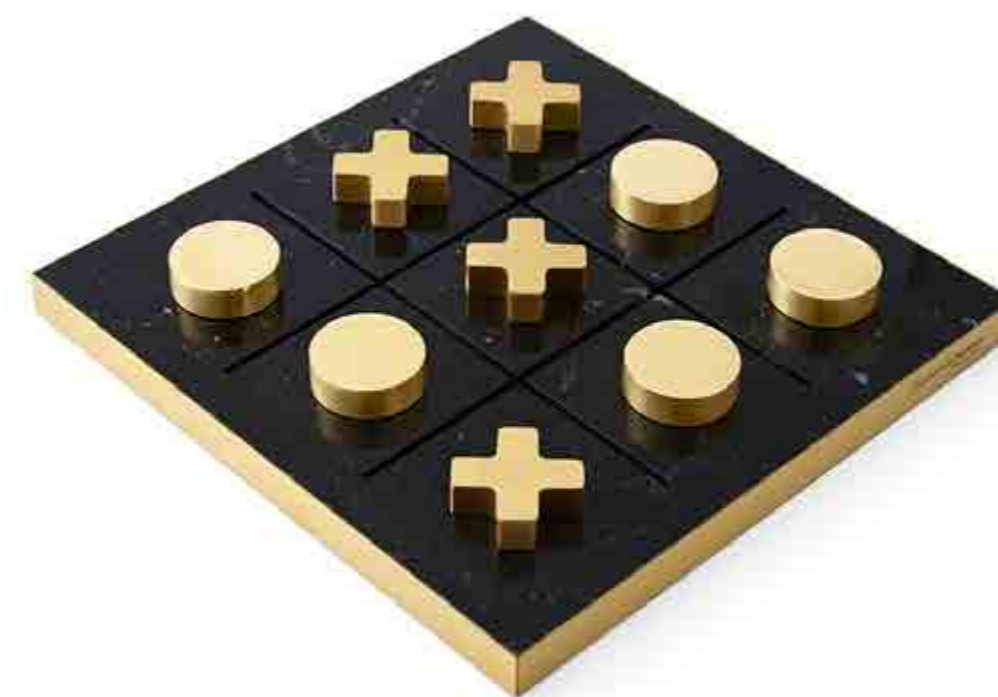

**Cm**  
28 x 28 x 4

**Inches**  
11¼" x 11¼" x 1¼"

[For technical drawing / p. 721](#)

[Pricelist 2023 / p. 328](#)

## BASE/BASE



Marmo lucido naturale  
Nero Marquinia/  
Ottone satinato  
Natural polished  
Nero Marquinia marble/  
Satin brass

## PEDINE/ PAWNS

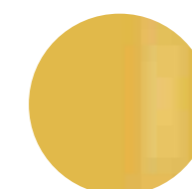

Ottone lucido  
Bright brass



Ottone satinato  
Satin brass

# 18

**Accessori / Accessories**  
**TECHNICAL MODULE**

Vase 1968 | Silvia Gallotti, 2018

Product information / p. 686

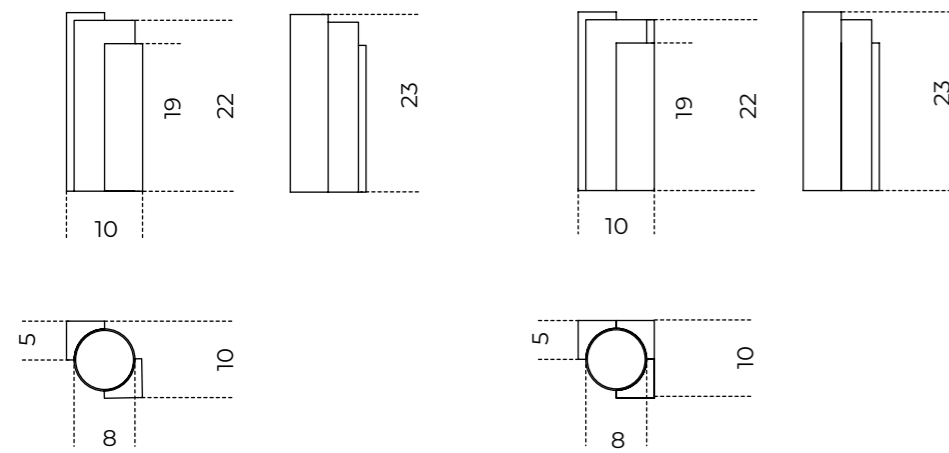

M2

M3

Candle Holder | Studio G&R, 2014

Product information / p. 688

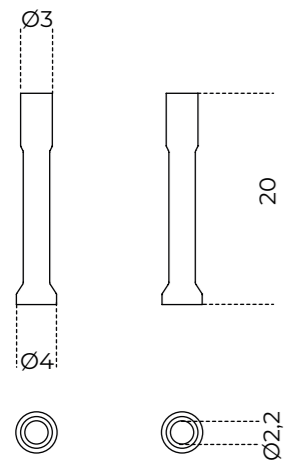

Candle Holder Hexagonal | Studio G&R, 2014

Product information / p. 689

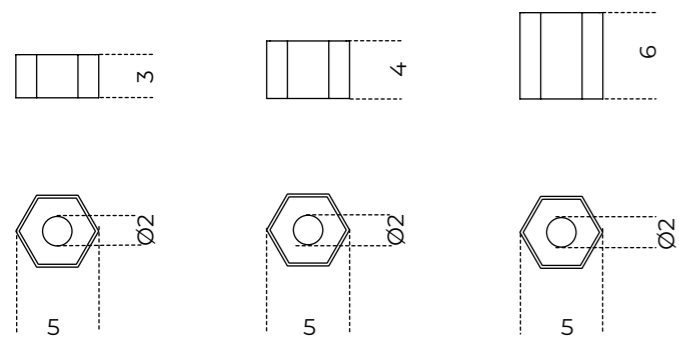

Desk Card Holder | Studio G&R, 2014

Product information / p. 690

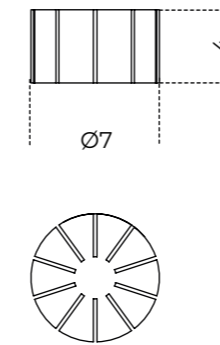

Desk Set | Silvia Gallotti, 2019

Product information / p. 692

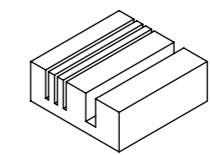
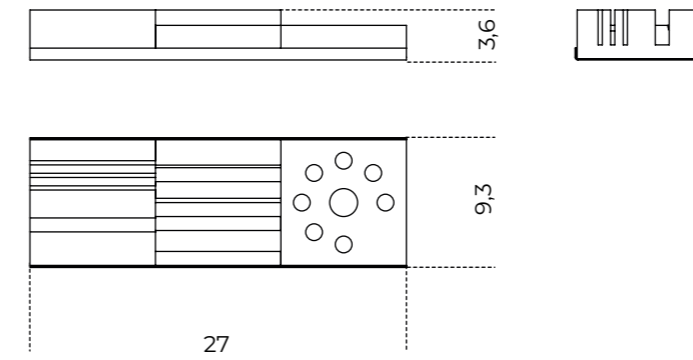

Porta biglietti  
Business card holder

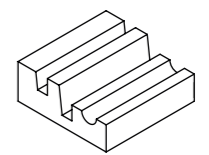

Calendario  
Calendar

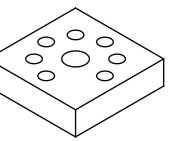

Portapenne  
Pen holder

Fiabello | Lanzavecchia + Wai, 2017

Product information / p. 694

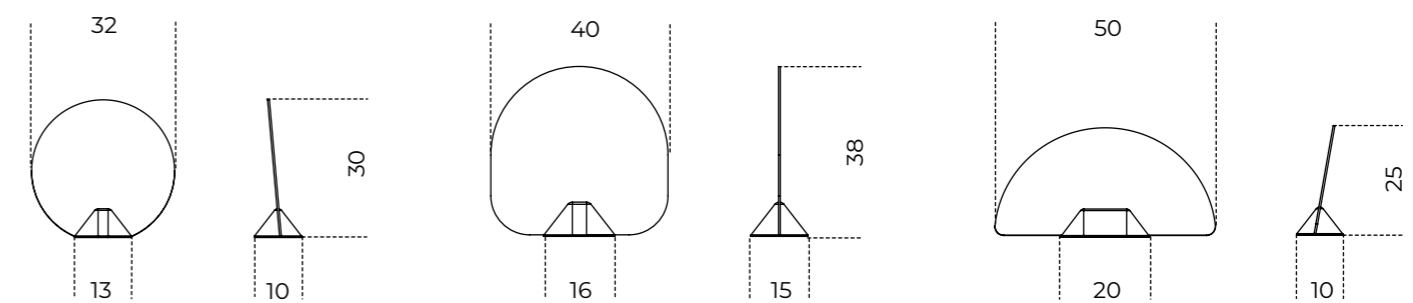

S

M

L

**Folded Tray** | Studio G&R, 2014

[Product information / p. 696](#)

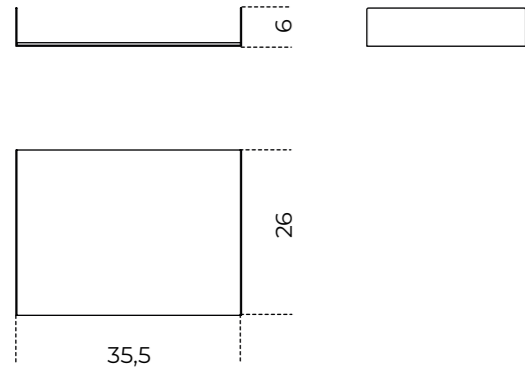

**Mouse Pad** | Studio G&R, 2009

[Product information / p. 701](#)

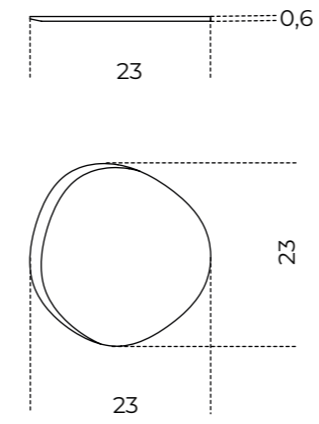

**Iperborea** | Studiopepe, 2024

[Product information / p. 798](#)

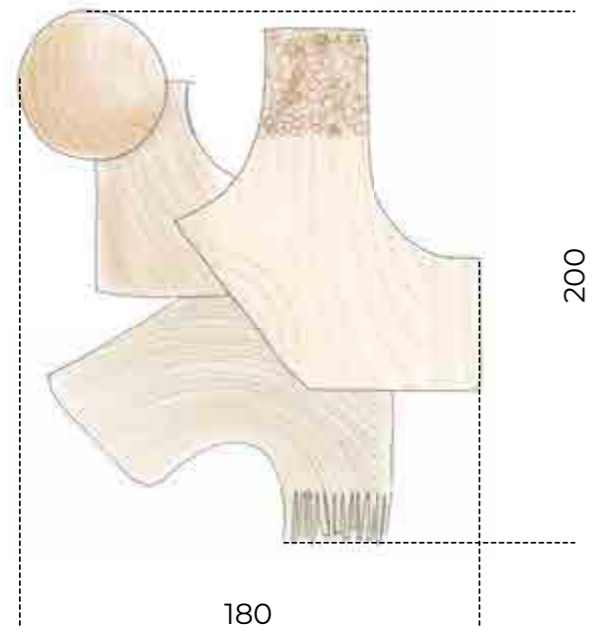

**Odette Tray** | Studio G&R, 2014

[Product information / p. 702](#)

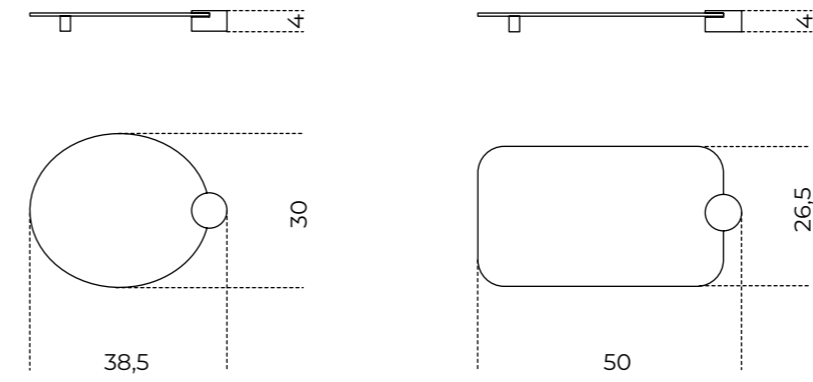

**Moonlight** | Silvia Gallotti, 2017

[Product information / p. 700](#)

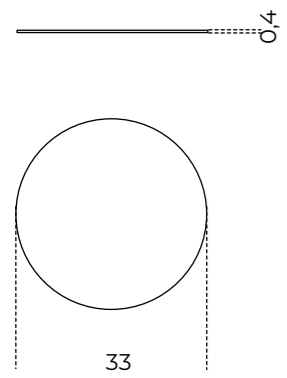

**Paperweight** | Studio G&R, 2014

[Product information / p. 704](#)

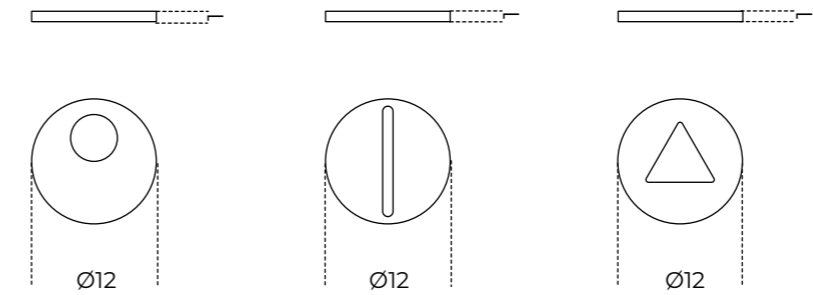

**PW.01**

**PW.02**

**PW.03**



**Pleiadi** | Studiopepe, 2023

Product information / p. 706

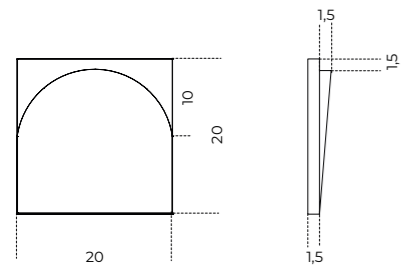

**Esempi di configurazioni**  
Configurations examples

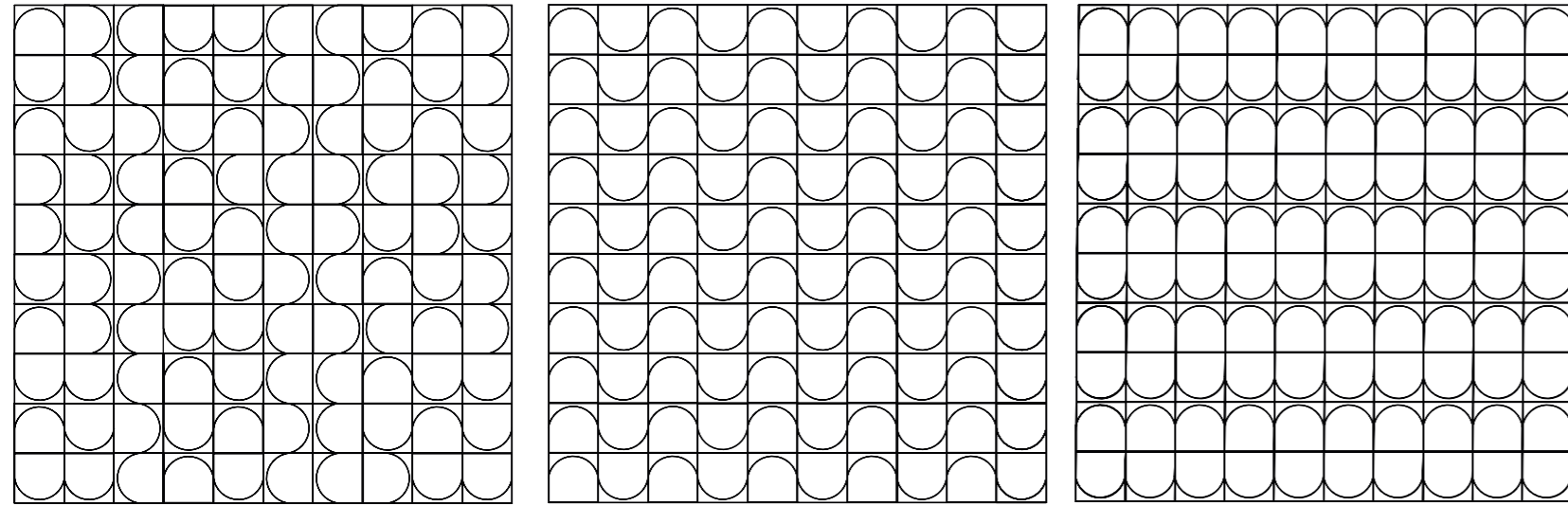

**200 x 200h**  
78¾" x 78¾"h

**200 x 200h**  
78¾" x 78¾"h

**200 x 200h**  
78¾" x 78¾"h

**Segno** | Elisa Ossino, 2018

Product information / p. 708

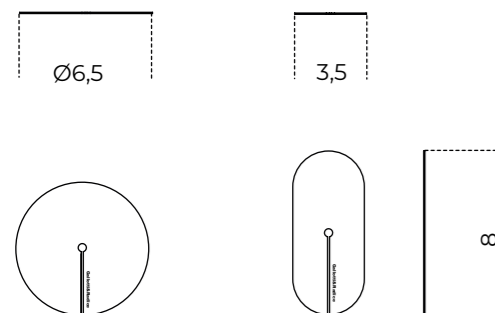

**Teddy** | Studio G&R, 2023

Product information / p. 709

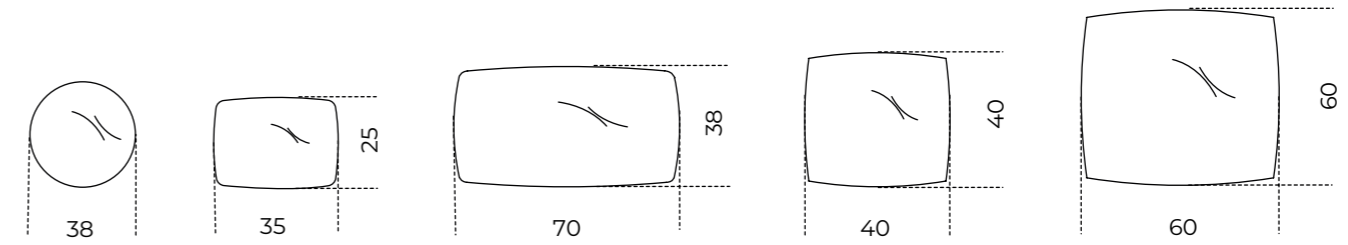

**Tic Tac 14** | Studio G&R, 2014

Product information / p. 710

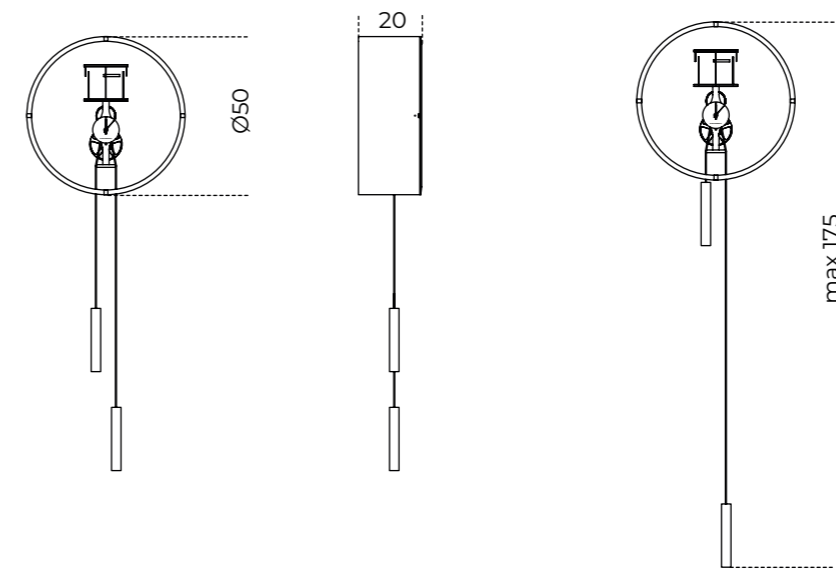

**Tip Tap Toe** | Silvia Gallotti, 2017

Product information / p. 712

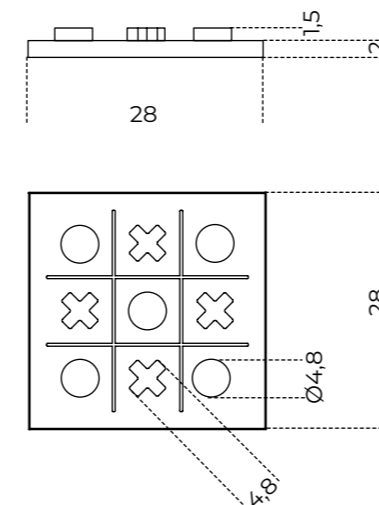



Gallotti&Radice srl  
via Matteotti, 17  
22072 Cermenate (Como) Italy  
T +39 031 777111  
info@gallottiradice.it  
gallottiradice.it